



**Cambridge International Examinations**  
Cambridge International General Certificate of Secondary Education (9–1)

---

**COMPUTER SCIENCE**

**0984/01**

Paper 1 Theory

**For examination from 2019**

MARK SCHEME

Maximum Mark: 75

---

**Specimen**

---

This document consists of **8** printed pages.

- 1 (a) 1 mark for the correct working in BOTH parts  
1 mark for valid  
1 mark for not valid

Identification number 1: working

$$\begin{aligned} &= (4 \times 6) + (2 \times 5) + (1 \times 4) + (9 \times 3) + (2 \times 2) + (3 \times 1) \\ &= 24 + 10 + 4 + 27 + 4 + 3 \\ &= 72 \div 11 \\ &= 6 \text{ remainder } 6 \\ &\text{valid/not valid: NOT valid} \end{aligned}$$

Identification number 2: working

$$\begin{aligned} &= (8 \times 6) + (2 \times 5) + (0 \times 4) + (1 \times 3) + (5 \times 2) + (6 \times 1) \\ &= 48 + 10 + 0 + 3 + 10 + 6 \\ &= 77 \div 11 \\ &= 7 \text{ remainder } 0 \\ &\text{valid/not valid: VALID} \end{aligned}$$

[3]

- (b) 1 mark for correct working + 1 mark for check digit

working

$$\begin{aligned} &= (5 \times 6) + (0 \times 5) + (2 \times 4) + (4 \times 3) + (1 \times 2) \\ &= 30 + 0 + 8 + 12 + 2 \\ &= 52 \end{aligned}$$

need to add **3** to make the total **55** (i.e. exactly divisible by 11)

check digit: 3

[2]

- (c) 1 mark for each description and example

2 digits transposed

(e.g. 280**4**19 becomes 280**1**49/two digits have been switched)

incorrect digit

(e.g. 280419 becomes 2**5**0419/one of the digits has been mistyped)

[2]

- 2 – direct access because of concentric tracks  
– can read and write at the same time because it has a read/write head

[2]

3 (a) 1 mark for each logic gate correctly connected

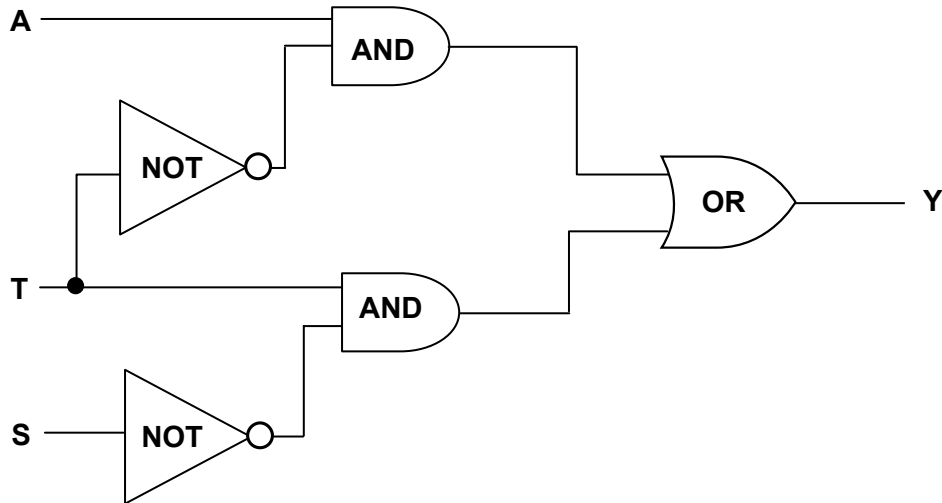

[5]

(b)

A	T	S	Y
0	0	0	0
0	0	1	0
0	1	0	1
0	1	1	0
1	0	0	1
1	0	1	1
1	1	0	1
1	1	1	0

1 mark  
1 mark  
1 mark  
1 mark

[4]

4 (a) 1 mark for hours; 1 mark for minutes

1 6 : 4 9  
1 mark 1 mark

[2]

(b) 1 mark for each digit

0 0 0 1      1<sup>st</sup> digit  
0 1 1 1      2<sup>nd</sup> digit  
0 0 1 0      3<sup>rd</sup> digit  
1 0 0 1      4<sup>th</sup> digit

[4]

- (c) Any **two** from:
- microprocessor compares present time with stored time
  - if the values are the same
  - sends signal to sound alarm
- [2]

5 (a) Yes [1]

(b) No [1]

- (c) – re-reading the byte that was sent  
– request that the byte is resent [2]

6 (a) Only answers:  
– temperature (sensor)  
– oxygen (sensor) [2]

- (b) Any **four** from:
- information from the sensors sent to microprocessor
  - the ADC converts the analogue data into digital form
  - if temperature < 25°C OR temperature checked against stored value
  - ...microprocessor sends signal to heater/actuator/valve...
  - ...to switch on heater
  - if oxygen level < 20 ppm OR oxygen level checked against stored value
  - ...to open valve/oxygen supply
  - use of DAC between microprocessor and devices
  - sounds an alarm if system unable to respond
  - continuously monitors sensor inputs
  - any reference to feedback
- [4]

- (c) Any **one** from:
- unsafe limit stored in memory
  - warning sound/signal if too high a value reached
  - fail safe switch off in case of a malfunction
- [1]

7 (a)

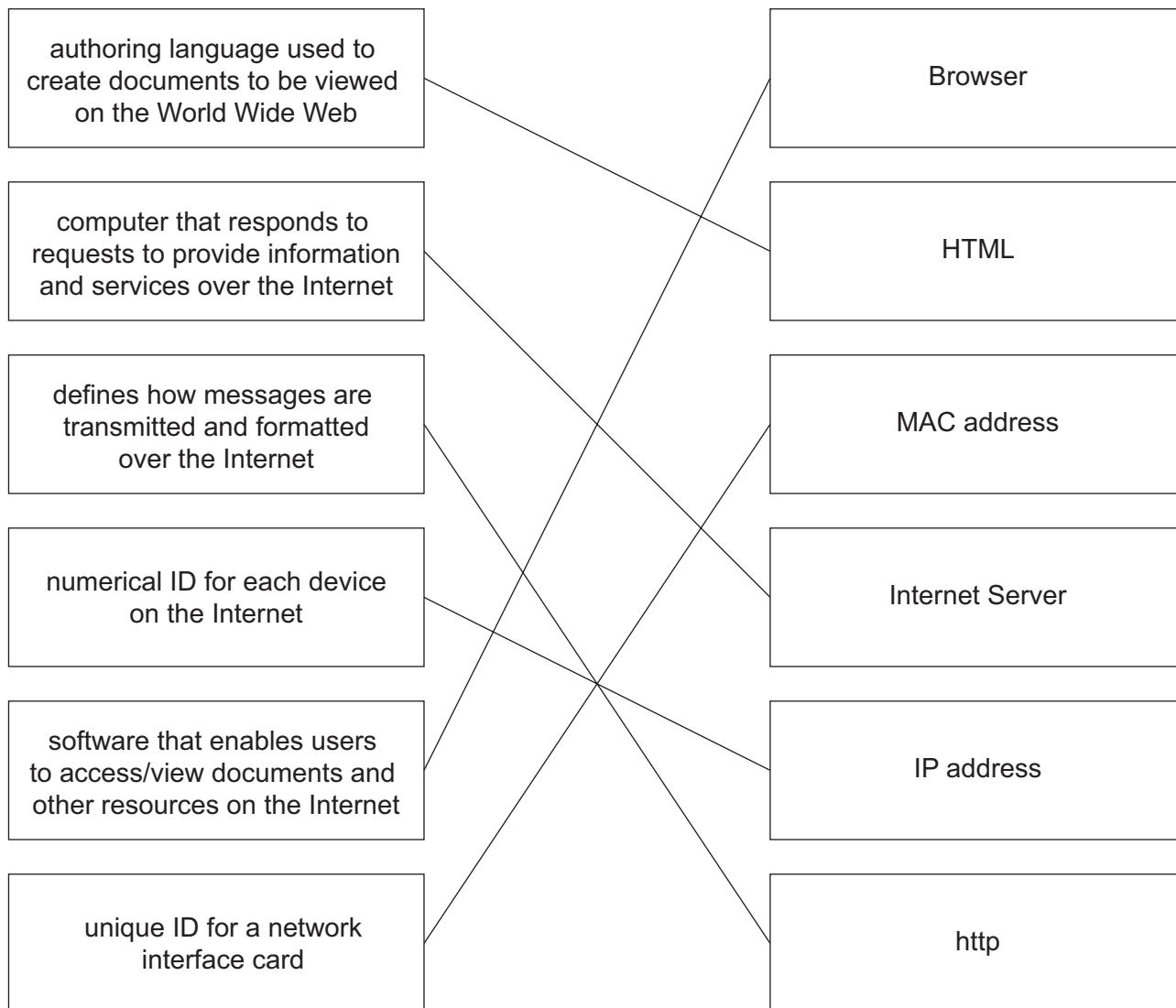

5/6 matches – 5 marks

4 matches – 4 marks

3 matches – 3 marks

2 matches – 2 marks

1 match – 1 mark

[5]

(b) any **two** from:

- to enable logon information to be kept on his computer
- to provide pages customised for Ahmed the next time he logs on
- to implement shopping carts and one-click purchasing
- to be able to distinguish between new and repeat visitors to the website

[2]

- 8 (a) (i)** Any **one** from:
- unit of data/memory
  - 8 bits
  - used to represent a character
- [1]
- (ii)** 30 [1]
- (b)** Any **two** from:
- Flash memory
- solid state memory
  - no formatting issues
  - plugs directly into the USB port
  - direct transfer of data
- CD-RW
- optical media
  - slower access speed/flash memory has faster access speed
  - requires a separate drive
  - data needs to be burnt/finalised/finished (before being used on another device)
- [2]
- 9 (a)** Any **one** from:
- buffer
  - RAM
- [1]
- (b)** – interrupt [1]
- 10 (a)** 1 mark for each correct word
- (i)** Hello World [2]
- (ii)** Vmilozgu Rvwgyvg [2]
- (b) (i)** Secure Socket Layer [1]
- (ii)** the key itself is encrypted using strong encryption [1]

11

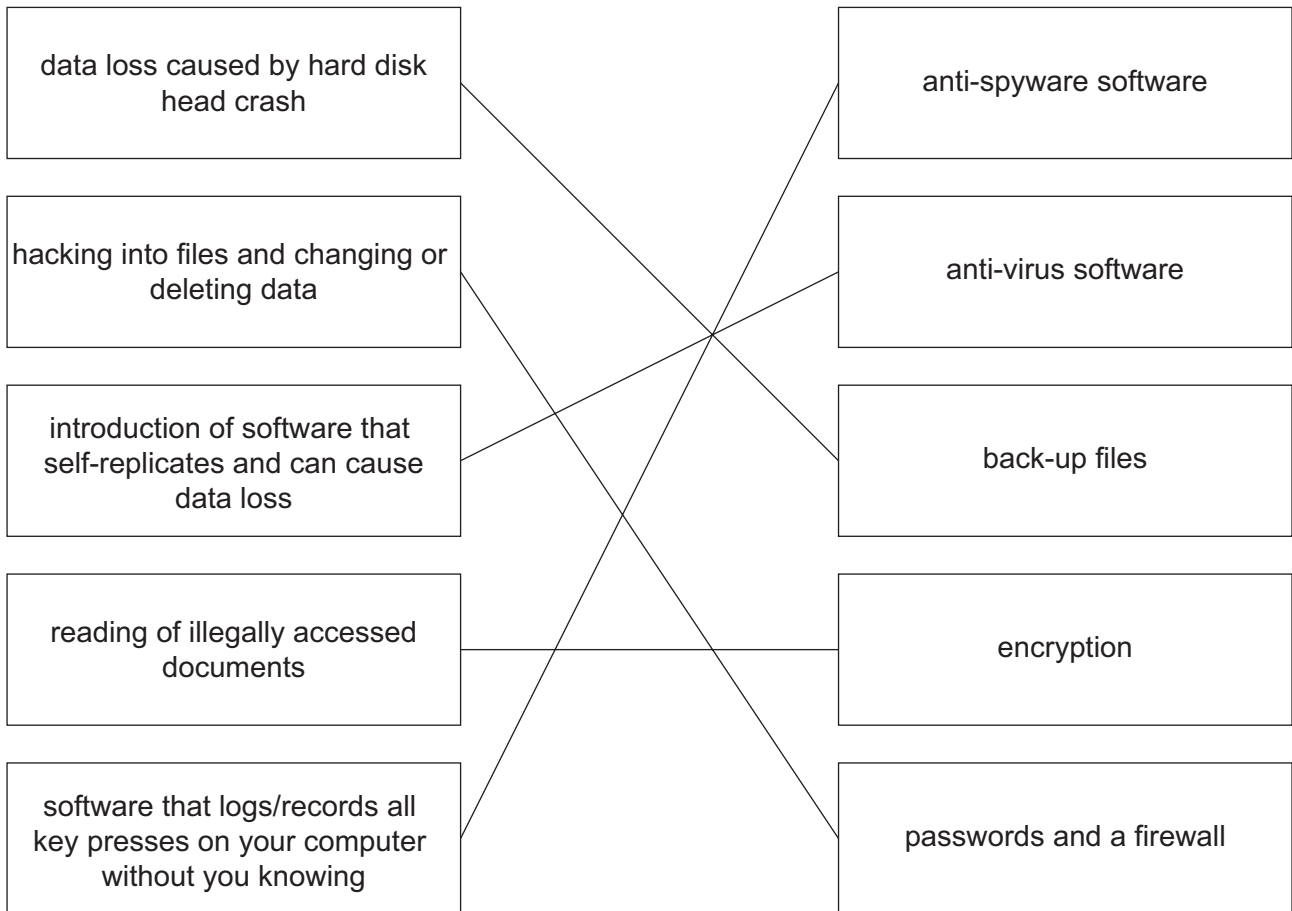

5/4 matches – 4 marks

3 matches – 3 marks

2 matches – 2 marks

1 match – 1 mark

[4]

12 (a) code B

[1]

(b) Any **one** from:

- no need to understand workings of a computer
- easier to understand for programmer/closer to English
- much easier to debug
- much easier to test
- one-to-many when writing commands
- not machine-specific/portable

[1]

(c) Any **one** from:

- can address memory addresses directly
- no need for compilers/interpreters
- shorter code/code requires less storage/RAM
- can be written to run faster

[1]

- (d) – compiler produces object code / interpreter doesn't produce object code  
– compiler translates whole program in one go / interpreter translates and executes line at a time  
– compiler produces list of all errors / interpreter produces error message each time an error encountered  
– compiler produces "stand alone code" / interpreter doesn't produce "stand alone code"  
– compilation process is slow but resultant code runs very quickly / interpreted code runs slowly [2]

13 (a) (i)

Location 1	0	1	0	0	0	0	0	1
------------	---	---	---	---	---	---	---	---

Location 2	0	1	0	0	0	0	1	1
------------	---	---	---	---	---	---	---	---

[2]

(ii) 41  
43

[2]

(b) FA97

[4]

- (c) – easier to identify values  
– easier to spot errors

[2]