

Write your name here

Surname

Other names

Pearson Edexcel
International
Advanced Level

Centre Number

--	--	--	--	--	--

Candidate Number

--	--	--	--	--

Physics

Advanced

Unit 4: Physics on the Move

Monday 4 June 2018 – Afternoon

Time: 1 hour 35 minutes

Paper Reference

WPH04/01**You must have:**

Ruler

Total Marks

Instructions

- Use **black** ink or ball-point pen.
- **Fill in the boxes** at the top of this page with your name, centre number and candidate number.
- Answer **all** questions.
- Answer the questions in the spaces provided
– *there may be more space than you need.*

Information

- The total mark for this paper is 80.
- The marks for **each** question are shown in brackets
– *use this as a guide as to how much time to spend on each question.*
- Questions labelled with an **asterisk** (*) are ones where the quality of your written communication will be assessed
– *you should take particular care with your spelling, punctuation and grammar, as well as the clarity of expression, on these questions.*
- The list of data, formulae and relationships is printed at the end of this booklet.
- Candidates may use a scientific calculator.

Advice

- Read each question carefully before you start to answer it.
- Try to answer every question.
- Check your answers if you have time at the end.

Turn over ►

P51940A

©2018 Pearson Education Ltd.

1/1/1/1/1/1/1/



Pearson

SECTION A

Answer ALL questions.

For questions 1–10, in Section A, select one answer from A to D and put a cross . If you change your mind, put a line through the box and then mark your new answer with a cross .

- 1 The isotope $^{209}_{84}\text{Po}$ decays by emitting an alpha particle.

Which of the following correctly shows the nucleons in the isotope produced?

- A 123 neutrons, 82 protons
 B 129 neutrons, 80 protons
 C 205 neutrons, 82 protons
 D 207 neutrons, 80 protons

(Total for Question 1 = 1 mark)

- 2 Two objects collide and rebound.

Select the row of the table that is correct for the total momentum and total kinetic energy of the objects in an inelastic collision.

	Total momentum	Total kinetic energy
<input type="checkbox"/> A	conserved	conserved
<input type="checkbox"/> B	conserved	not conserved
<input type="checkbox"/> C	not conserved	conserved
<input type="checkbox"/> D	not conserved	not conserved

(Total for Question 2 = 1 mark)

- 3 A potential difference V is applied across two identical capacitors of capacitance C connected in parallel.

Which of the following expressions gives the total energy stored on the capacitors?

- A $\frac{1}{4}CV^2$
 B $\frac{1}{2}CV^2$
 C CV^2
 D $2CV^2$

(Total for Question 3 = 1 mark)



Questions 4 and 5 refer to the following situation.

The diagram shows an electron deflection tube.

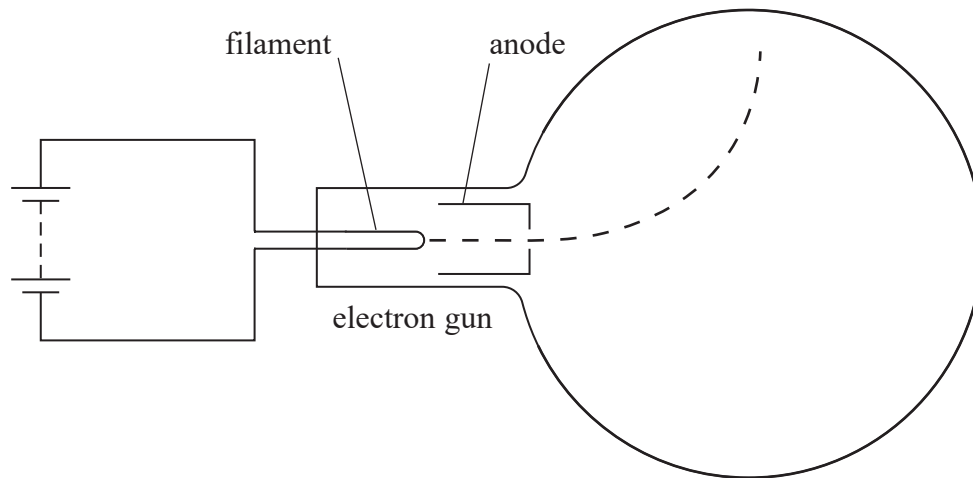

Electrons are released by a filament and accelerated towards the anode, producing a beam. A magnetic field is applied, deflecting the beam as shown.

4 Which of the following causes electrons to be released from the filament?

- A beta decay
- B ionisation
- C photoelectric effect
- D thermionic emission

(Total for Question 4 = 1 mark)

5 In which direction is the magnetic field applied to result in the deflection shown?

- A from the bottom of the tube to the top of the tube
- B from the top of the tube to the bottom of the tube
- C into the page
- D out of the page

(Total for Question 5 = 1 mark)



6 Which of the following decays for a pion would **not** be possible?

- A $\pi^0 \rightarrow 2\gamma$
- B $\pi^+ \rightarrow e^+ + \nu_e$
- C $\pi^0 \rightarrow e^+ + \bar{\nu}_e$
- D $\pi^0 \rightarrow e^+ + e^- + \gamma$

(Total for Question 6 = 1 mark)

7 The table shows the six types of quark and their relative charges.

Quark			Charge / e
u	c	t	$\frac{2}{3}$
d	s	b	$-\frac{1}{3}$

Which of the following shows a possible quark composition for a baryon with charge $-e$?

- A $c c \bar{s}$
- B $d s s$
- C $u u d$
- D $\bar{u} \bar{u} b$

(Total for Question 7 = 1 mark)

8 Two identical point charges Q_1 and Q_2 are placed a small distance apart.

The force acting on Q_1 has magnitude F .

The charge Q_1 and the distance between the charges are both doubled. The charge Q_2 is unchanged.

What is the magnitude of the new force on Q_1 ?

- A $2F$
- B F
- C $\frac{F}{2}$
- D $\frac{F}{4}$

(Total for Question 8 = 1 mark)



- 9 A magnet is pushed through a coil of wire at a steady speed, inducing an e.m.f. ϵ in the coil.
The following graph shows how ϵ varies with time t .

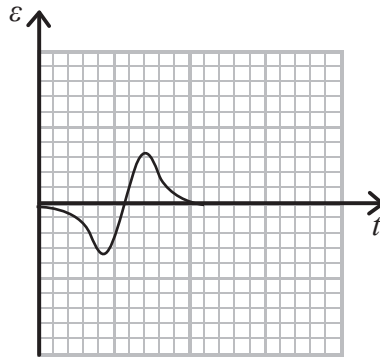

The magnet is then pushed through in the same direction at a higher speed.
Which of the following shows the graph of ϵ against t for the higher speed?

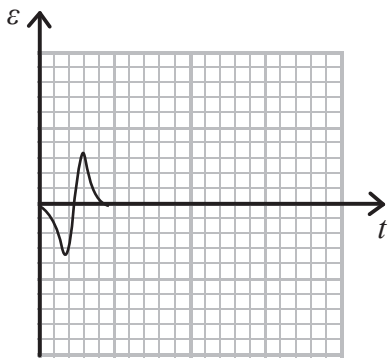

A

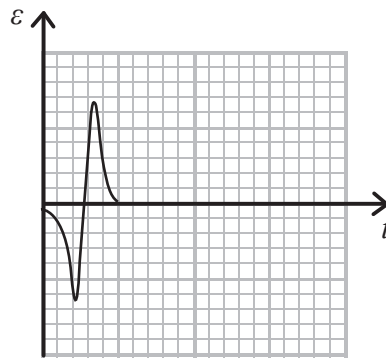

B

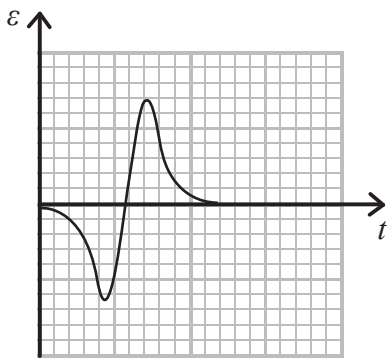

C

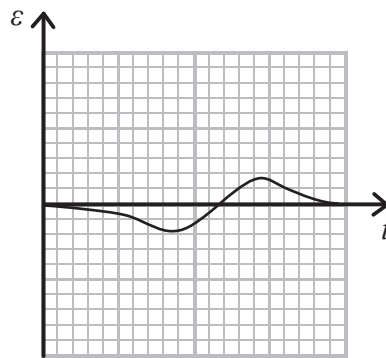

D

(Total for Question 9 = 1 mark)

DO NOT WRITE IN THIS AREA

DO NOT WRITE IN THIS AREA

DO NOT WRITE IN THIS AREA



10 Two conducting plates are 5 cm apart. The potential difference between the plates is 10 V as shown.

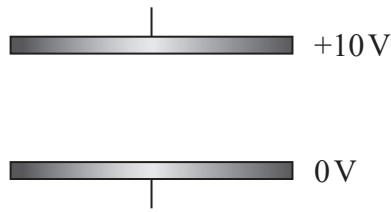

Which diagram correctly shows the electric field between the plates?

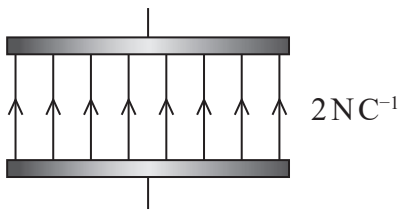

A

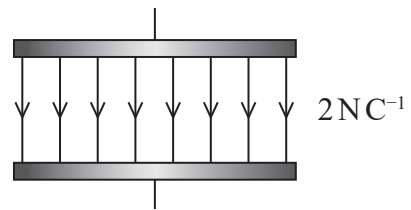

B

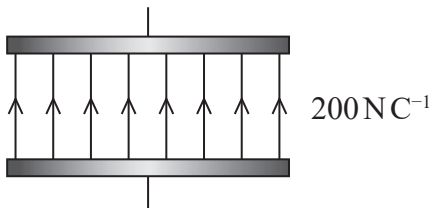

C

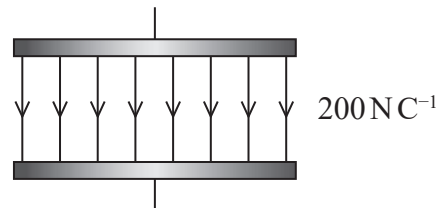

D

(Total for Question 10 = 1 mark)

TOTAL FOR SECTION A = 10 MARKS

DO NOT WRITE IN THIS AREA

DO NOT WRITE IN THIS AREA

DO NOT WRITE IN THIS AREA



SECTION B

Answer ALL questions in the spaces provided.

- 11 An electron travels through a uniform electric field for a time of 4.3×10^{-9} s. It is deviated from its original path as shown.

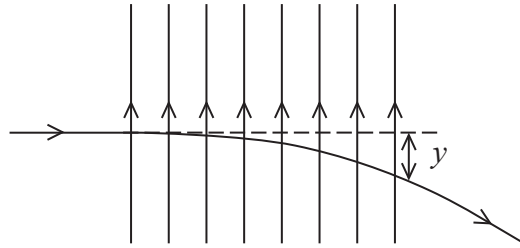

Calculate the deflection y of the electron.

(4)

electric field strength = $1.3 \times 10^4 \text{NC}^{-1}$

$y = \dots\dots\dots$

(Total for Question 11 = 4 marks)

DO NOT WRITE IN THIS AREA

DO NOT WRITE IN THIS AREA

DO NOT WRITE IN THIS AREA



12 In the early 20th century, experiments were carried out in which high-speed alpha particles were directed at thin gold foil.

A simplified version of the apparatus used is shown.

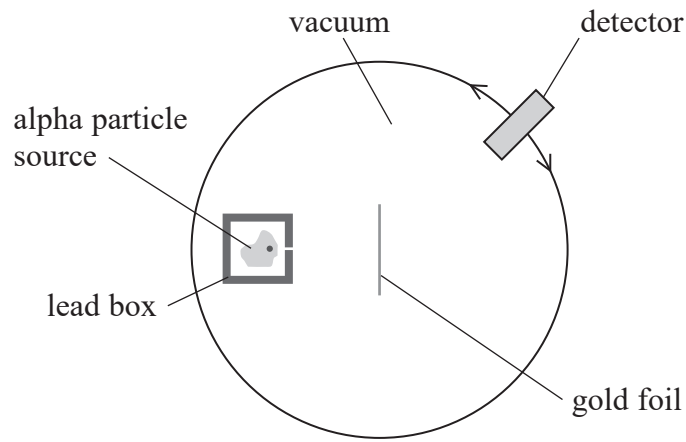

(a) State two observations and corresponding conclusions made from the alpha particle scattering experiment.

(4)

.....

.....

.....

.....

.....

.....

.....

.....

DO NOT WRITE IN THIS AREA

DO NOT WRITE IN THIS AREA

DO NOT WRITE IN THIS AREA



(b) (i) Calculate the de Broglie wavelength of the alpha particles.

(4)

kinetic energy of alpha particles = 5.00 MeV

mass of alpha particle = 6.64×10^{-27} kg

.....

.....

.....

.....

.....

.....

.....

.....

.....

.....

.....

de Broglie wavelength =

(ii) Justify whether you would expect these alpha particles to be substantially diffracted by the gold foil.

(1)

separation of gold atoms = 2.88×10^{-10} m

.....

.....

(Total for Question 12 = 9 marks)

DO NOT WRITE IN THIS AREA

DO NOT WRITE IN THIS AREA

DO NOT WRITE IN THIS AREA



13 The muon was identified in 1936 from the tracks of cosmic rays passing through a particle detector. The tracks for the muon were seen to be different from those of electrons and protons.

The diagram represents particle tracks for an electron, a muon and a proton passing through a uniform magnetic field. The particles have the same initial kinetic energy.

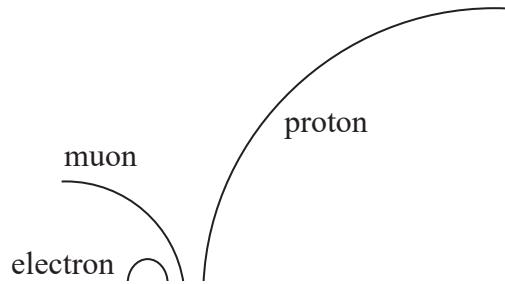

(a) Explain what can be deduced from the tracks about the mass and the charge of the muon. (3)

.....

.....

.....

.....

.....

.....

(b) The muon has a mass of $106 \text{ MeV}/c^2$.
Calculate the mass of the muon in kg. (3)

.....

.....

.....

.....

Mass = kg



DO NOT WRITE IN THIS AREA

DO NOT WRITE IN THIS AREA

DO NOT WRITE IN THIS AREA

- (c) The muon was originally called a mu meson. When other mesons were discovered, it was realised that the muon was not the same type of particle as other mesons.

Describe the differences between muons and mesons.

(2)

.....

.....

.....

.....

.....

(Total for Question 13 = 8 marks)

DO NOT WRITE IN THIS AREA

DO NOT WRITE IN THIS AREA

DO NOT WRITE IN THIS AREA



14 The diagram shows an investigation of circular motion.

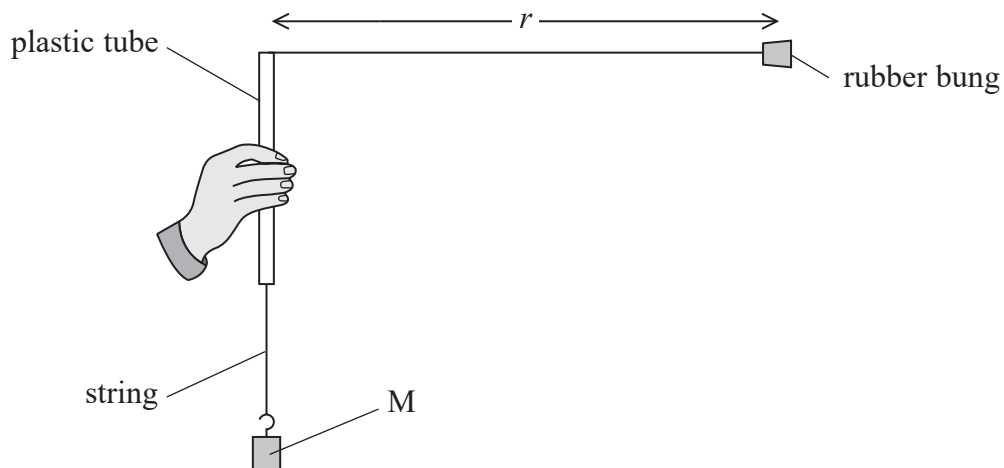

A small movement of the hand causes the rubber bung on the end of the string to move in a circular path of radius r . The rubber bung and the string may be assumed to rotate in a horizontal plane.

(a) For a particular experiment, r is 59 cm.

Calculate the speed of the rubber bung.

(3)

mass of $M = 250$ g

mass of rubber bung = 80 g

Speed =

DO NOT WRITE IN THIS AREA

DO NOT WRITE IN THIS AREA

DO NOT WRITE IN THIS AREA



(b) The speed of the rubber bung is increased.

Explain why M now moves to a higher position.

(3)

.....

.....

.....

.....

.....

.....

.....

.....

.....

(c) In order to calculate the speed of the rubber bung, the time for one rotation must be determined.

Student A suggests the number of rotations in a fixed time should be counted.

Student B suggests measuring the time for a fixed number of rotations.

Explain which method will produce more accurate results for the time of one rotation.

(2)

.....

.....

.....

.....

.....

.....

(Total for Question 14 = 8 marks)

DO NOT WRITE IN THIS AREA

DO NOT WRITE IN THIS AREA

DO NOT WRITE IN THIS AREA



15 The diagram shows a cyclotron.

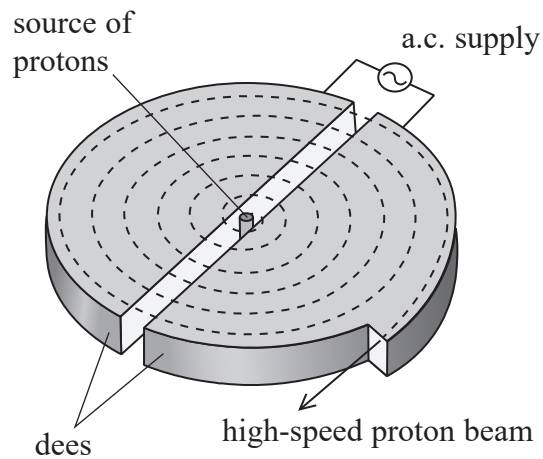

A magnetic field of uniform magnetic flux density B acts vertically upwards through the plane of the cyclotron. Protons travel along paths of increasing radius as their speed increases.

(a) (i) A proton of mass m and charge Q is travelling at a non-relativistic speed in the cyclotron.

Show that the time t for which a proton is in one of the dees is given by

$$t = \frac{\pi m}{BQ} \quad (2)$$

DO NOT WRITE IN THIS AREA

DO NOT WRITE IN THIS AREA

DO NOT WRITE IN THIS AREA



(ii) Explain why an alternating potential difference of constant frequency is applied to the dees.

(3)

DO NOT WRITE IN THIS AREA

.....

.....

.....

.....

.....

.....

*(b) In a cyclotron, high-energy protons are directed towards a stationary target.

In the Large Hadron Collider, beams of high-energy protons circulating in opposite directions cross, so that protons moving in opposite directions collide.

For the same initial total energy, the colliding proton beams allow the creation of particles of greater mass than the use of a stationary target.

Explain why, using the principle of conservation of momentum.

(4)

DO NOT WRITE IN THIS AREA

.....

.....

.....

.....

.....

.....

.....

.....

.....

.....

.....

.....

.....

.....

.....

.....

.....

.....

.....

.....

.....

.....

.....

DO NOT WRITE IN THIS AREA

(Total for Question 15 = 9 marks)



16 The diagram and photograph show a moving coil loudspeaker.

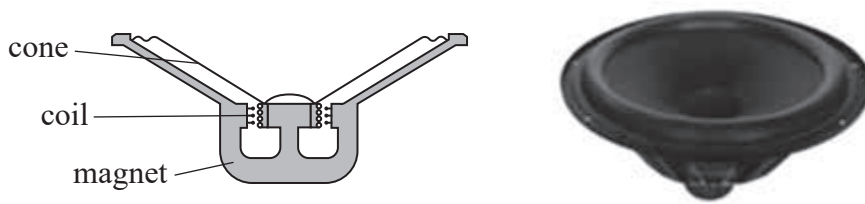

- (a) The loudspeaker contains a coil connected to a cone that is free to move. The coil is in a radial magnetic field. When there is a varying current in the coil, the magnetic force on it varies. This varying force causes the coil and cone to vibrate, producing sound waves.

The diagram below shows the magnet and the coil in the magnetic field.

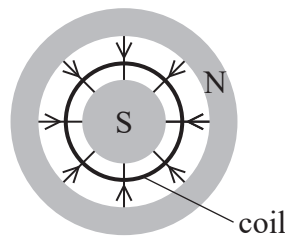

- (i) Explain why, even though the wire is not straight, the force F on a single turn of the coil can be calculated using

$$F = BIl$$

where l is the length of a single turn.

(2)

.....

.....

.....

.....

- (ii) Calculate the force acting on a coil of 120 turns.

(2)

$I = 0.11 \text{ A}$
 $B = 0.80 \text{ T}$
 diameter of coil = 4.5 cm

.....

.....

.....

.....

Force =

DO NOT WRITE IN THIS AREA

DO NOT WRITE IN THIS AREA

DO NOT WRITE IN THIS AREA



DO NOT WRITE IN THIS AREA

DO NOT WRITE IN THIS AREA

DO NOT WRITE IN THIS AREA

*(b) An amplifier unit can be used to amplify music from devices with small speakers, such as smartphones. In the amplifier unit there is a coil connected to an amplifier and a loudspeaker as shown.

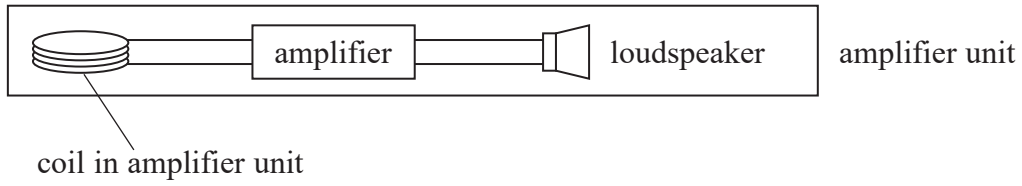

A smartphone is placed on the amplifier unit so that the coil in the smartphone speaker is above the coil in the amplifier unit.

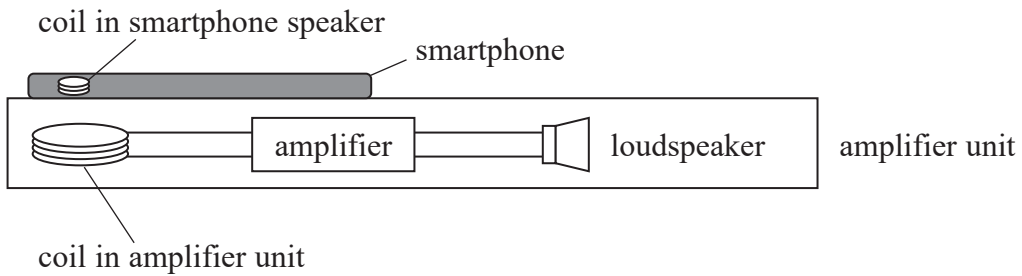

Explain how the music played by the smartphone is also played through the loudspeaker in the amplifier unit.

(4)

.....

.....

.....

.....

.....

.....

.....

.....

.....

.....

.....

.....

.....

.....

.....

.....

.....

.....

.....

.....

.....

.....

(Total for Question 16 = 8 marks)



DO NOT WRITE IN THIS AREA

DO NOT WRITE IN THIS AREA

DO NOT WRITE IN THIS AREA

BLANK PAGE



- 17 A student attempts to measure the speed of air leaving a hairdryer by measuring the force exerted by the air on an electronic balance.



- (a) The diagram shows the path of an object of mass m colliding with a surface at speed v at an angle θ .

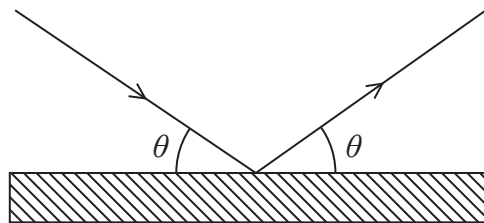

The collision takes a time t .

Explain why the force F exerted on the surface by a single collision is given by

$$F = \frac{2mv\sin\theta}{t}$$

(4)

.....

.....

.....

.....

.....

.....

.....

.....

.....

.....



DO NOT WRITE IN THIS AREA

DO NOT WRITE IN THIS AREA

DO NOT WRITE IN THIS AREA

(b) The student varies the angle θ at which he holds the hairdryer. A graph of the force F_B acting on the electronic balance against $\sin \theta$ is plotted.

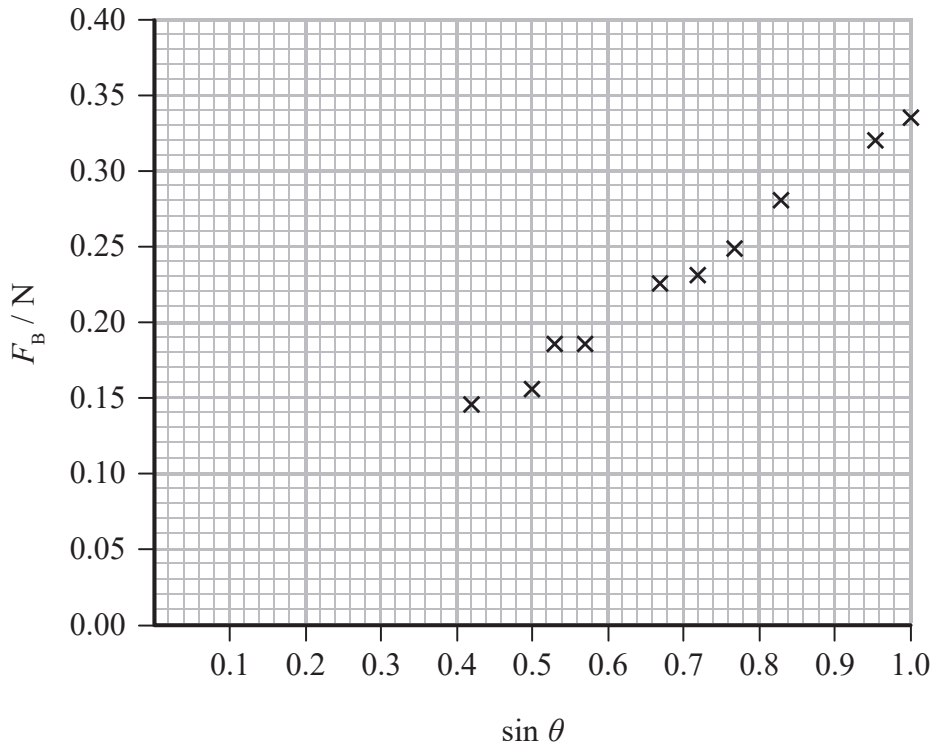

The average mass of air striking the electronic balance per unit time is given by $vA\rho$, where A is the area of the hairdryer nozzle and ρ is the density of air.

(i) The student assumes that the air behaves as in part (a).

Show that, in this case, the gradient of the graph is $2v^2A\rho$.

(3)

.....

.....

.....

.....

.....

.....



(ii) Calculate the speed of the air.

(3)

area of hairdryer nozzle = $2.0 \times 10^{-3} \text{ m}^2$

density of air = 1.2 kg m^{-3}

.....

.....

.....

.....

.....

.....

Speed of the air =

(c) Suggest why the speed calculated in part (b)(ii) might be incorrect.

(2)

.....

.....

.....

.....

(Total for Question 17 = 12 marks)

DO NOT WRITE IN THIS AREA

DO NOT WRITE IN THIS AREA

DO NOT WRITE IN THIS AREA



18 A student investigating capacitors uses the circuit shown.

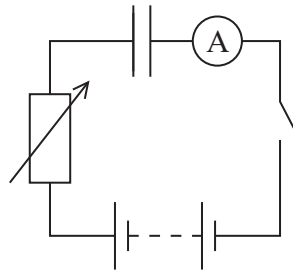

The capacitor is initially uncharged. When the switch is closed, there is a current in the circuit and the capacitor charges.

The resistance of the variable resistor is adjusted as the capacitor charges in order to maintain a constant current in the circuit.

After a time of 132 s the capacitor is fully charged.

(a) Show that the capacitance of the capacitor is about $5000 \mu\text{F}$.

(4)

initial resistance = $28.0 \text{ k}\Omega$

applied potential difference = 6.00 V

.....

.....

.....

.....

.....

.....

.....

.....

(b) Explain whether the resistance of the variable resistor is steadily increased or steadily decreased in order to maintain a constant current.

(3)

.....

.....

.....

.....

.....

DO NOT WRITE IN THIS AREA

DO NOT WRITE IN THIS AREA

DO NOT WRITE IN THIS AREA



(c) A textbook states “In a circuit with constant resistance, the time to fully discharge a capacitor is equal to $5RC$ ”.

(i) Show that RC has the unit of seconds.

(2)

.....

.....

.....

.....

.....

.....

(ii) Evaluate the statement from the textbook. Your answer should include a suitable calculation.

(3)

.....

.....

.....

.....

.....

.....

(Total for Question 18 = 12 marks)

TOTAL FOR SECTION B = 70 MARKS

TOTAL FOR PAPER = 80 MARKS

DO NOT WRITE IN THIS AREA

DO NOT WRITE IN THIS AREA

DO NOT WRITE IN THIS AREA



DO NOT WRITE IN THIS AREA

DO NOT WRITE IN THIS AREA

DO NOT WRITE IN THIS AREA

BLANK PAGE



DO NOT WRITE IN THIS AREA

DO NOT WRITE IN THIS AREA

DO NOT WRITE IN THIS AREA

BLANK PAGE



P 5 1 9 4 0 A 0 2 5 2 8

List of data, formulae and relationships

Acceleration of free fall	$g = 9.81 \text{ m s}^{-2}$	(close to Earth's surface)
Boltzmann constant	$k = 1.38 \times 10^{-23} \text{ J K}^{-1}$	
Coulomb's law constant	$k = 1/4\pi\epsilon_0$ $= 8.99 \times 10^9 \text{ N m}^2 \text{ C}^{-2}$	
Electron charge	$e = -1.60 \times 10^{-19} \text{ C}$	
Electron mass	$m_e = 9.11 \times 10^{-31} \text{ kg}$	
Electronvolt	$1 \text{ eV} = 1.60 \times 10^{-19} \text{ J}$	
Gravitational constant	$G = 6.67 \times 10^{-11} \text{ N m}^2 \text{ kg}^{-2}$	
Gravitational field strength	$g = 9.81 \text{ N kg}^{-1}$	(close to Earth's surface)
Permittivity of free space	$\epsilon_0 = 8.85 \times 10^{-12} \text{ F m}^{-1}$	
Planck constant	$h = 6.63 \times 10^{-34} \text{ J s}$	
Proton mass	$m_p = 1.67 \times 10^{-27} \text{ kg}$	
Speed of light in a vacuum	$c = 3.00 \times 10^8 \text{ m s}^{-1}$	
Stefan-Boltzmann constant	$\sigma = 5.67 \times 10^{-8} \text{ W m}^{-2} \text{ K}^{-4}$	
Unified atomic mass unit	$u = 1.66 \times 10^{-27} \text{ kg}$	

Unit 1*Mechanics*

Kinematic equations of motion	$v = u + at$ $s = ut + \frac{1}{2}at^2$ $v^2 = u^2 + 2as$
Forces	$\Sigma F = ma$ $g = F/m$ $W = mg$
Work and energy	$\Delta W = F\Delta s$ $E_k = \frac{1}{2}mv^2$ $\Delta E_{\text{grav}} = mg\Delta h$

Materials

Stokes' law	$F = 6\pi\eta rv$
Hooke's law	$F = k\Delta x$
Density	$\rho = m/V$
Pressure	$p = F/A$
Young modulus	$E = \sigma/\epsilon$ where Stress $\sigma = F/A$ Strain $\epsilon = \Delta x/x$
Elastic strain energy	$E_{\text{el}} = \frac{1}{2}F\Delta x$



Unit 2*Waves*

Wave speed

$$v = f\lambda$$

Refractive index

$${}_1\mu_2 = \sin i / \sin r = v_1 / v_2$$

Electricity

Potential difference

$$V = W/Q$$

Resistance

$$R = V/I$$

Electrical power, energy and efficiency

$$P = VI$$

$$P = I^2R$$

$$P = V^2/R$$

$$W = VI t$$

$$\% \text{ efficiency} = \frac{\text{useful energy output}}{\text{total energy input}} \times 100$$

$$\% \text{ efficiency} = \frac{\text{useful power output}}{\text{total power input}} \times 100$$

Resistivity

$$R = \rho l/A$$

Current

$$I = \Delta Q / \Delta t$$

$$I = nqvA$$

Resistors in series

$$R = R_1 + R_2 + R_3$$

Resistors in parallel

$$\frac{1}{R} = \frac{1}{R_1} + \frac{1}{R_2} + \frac{1}{R_3}$$

Quantum physics

Photon model

$$E = hf$$

Einstein's photoelectric equation

$$hf = \phi + \frac{1}{2}mv_{\max}^2$$

DO NOT WRITE IN THIS AREA

DO NOT WRITE IN THIS AREA

DO NOT WRITE IN THIS AREA



Unit 4*Mechanics*

Momentum	$p = mv$
Kinetic energy of a non-relativistic particle	$E_k = p^2/2m$
Motion in a circle	$v = \omega r$ $T = 2\pi/\omega$ $F = ma = mv^2/r$ $a = v^2/r$ $a = r\omega^2$

Fields

Coulomb's law	$F = kQ_1Q_2/r^2$ where $k = 1/4\pi\epsilon_0$
Electric field	$E = F/Q$ $E = kQ/r^2$ $E = V/d$
Capacitance	$C = Q/V$
Energy stored in capacitor	$W = \frac{1}{2}QV$
Capacitor discharge	$Q = Q_0 e^{-t/RC}$
In a magnetic field	$F = BIl \sin \theta$ $F = Bqv \sin \theta$ $r = p/BQ$
Faraday's and Lenz's laws	$\epsilon = -d(N\phi)/dt$

Particle physics

Mass-energy	$\Delta E = c^2 \Delta m$
de Broglie wavelength	$\lambda = h/p$

DO NOT WRITE IN THIS AREA

DO NOT WRITE IN THIS AREA

DO NOT WRITE IN THIS AREA

