

Write your name here

Surname

Other names

Centre Number

Candidate Number

Edexcel GCE

Physics

Advanced Subsidiary**Unit 3B: Exploring Physics****International Alternative to Internal Assessment**

Tuesday 10 January 2012 – Morning

Time: 1 hour 20 minutes

Paper Reference

6PH07/01**You must have:**

Ruler

Total Marks

Instructions

- Use **black** ink or ball-point pen.
- **Fill in the boxes** at the top of this page with your name, centre number and candidate number.
- Answer **all** questions.
- Answer the questions in the spaces provided – *there may be more space than you need.*

Information

- The total mark for this paper is 40.
- The marks for **each** question are shown in brackets – *use this as a guide as to how much time to spend on each question.*
- The list of data, formulae and relationships is printed at the end of this booklet.
- Candidates may use a scientific calculator.

Advice

- Read each question carefully before you start to answer it.
- Keep an eye on the time.
- Try to answer every question.
- Check your answers if you have time at the end.

Turn over ►

P39851A

©2012 Pearson Education Ltd.

6/6/6/6/6/

**PEARSON**

SECTION A

Answer ALL questions.

For questions 1–5, in Section A, select one answer from A to D and put a cross in the box . If you change your mind, put a line through the box and then mark your new answer with a cross .

- 1 A student is trying to determine his reaction time. He takes the following readings:

0.20 s, 0.18 s, 0.19 s, 0.08 s

Which of the following is the best mean value of his reaction time stated with a suitable uncertainty?

- A 0.19 ± 0.06 s
 B 0.19 ± 0.01 s
 C 0.16 ± 0.06 s
 D 0.16 ± 0.01 s

(Total for Question 1 = 1 mark)

- 2 Which of the following is the SI unit for resistivity?

- A Ω
 B $\Omega \text{ m}$
 C $\Omega^{-1} \text{ m}$
 D $\Omega \text{ m}^{-1}$

(Total for Question 2 = 1 mark)

- 3 An experiment to determine the acceleration due to gravity uses a free-falling ball. Which of the following measurements would **not** be needed?

- A initial velocity
 B final velocity
 C mass of the ball
 D time taken

(Total for Question 3 = 1 mark)



Questions 4 and 5 refer to the circuit below.

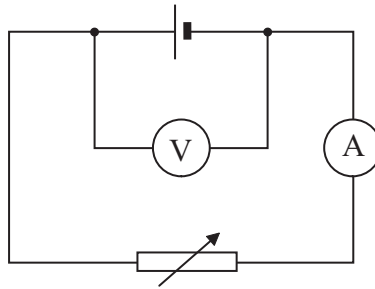

The variable resistor is used to change the current. A graph is drawn with potential difference on the y -axis and current on the x -axis.

4 Which of the following would give the emf of the cell?

- A area under the graph
- B gradient of the graph
- C intercept on the x -axis
- D intercept on the y -axis

(Total for Question 4 = 1 mark)

5 Which of the following would give the magnitude of the internal resistance of the cell?

- A area under the graph
- B gradient of the graph
- C intercept on the x -axis
- D intercept on the y -axis

(Total for Question 5 = 1 mark)

TOTAL FOR SECTION A = 5 MARKS



SECTION B

Answer ALL questions in the spaces provided.

6 A student is asked to determine the resistance of a wire.

The student has to decide whether to measure the resistance directly, using a digital multimeter, or indirectly, using an analogue ammeter with an analogue voltmeter. The resistance is known to be between $5\ \Omega$ and $15\ \Omega$.

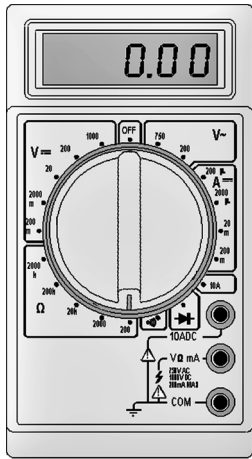

Digital multimeter

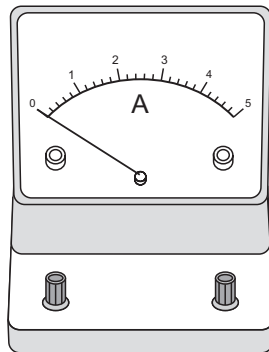

Analogue ammeter

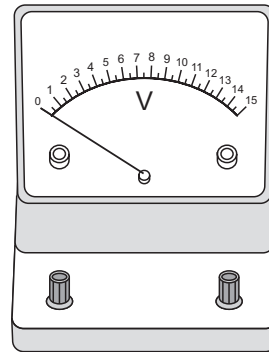

Analogue voltmeter

Discuss the advantages and disadvantages of each method of measuring the resistance.

(5)

.....

.....

.....

.....

.....

.....

.....

.....

.....

.....

.....

.....

.....

.....

.....

.....

.....

.....

.....

.....

.....

.....

.....

(Total for Question 6 = 5 marks)



BLANK PAGE



- 7 A student is asked to determine the viscosity of an oil at room temperature by dropping ball bearings into a long measuring cylinder filled with the oil.

The student is given the equation:

$$v = \frac{2}{9} r^2 \frac{g}{\eta} (\rho_b - \rho_o)$$

Where

v = velocity of ball bearing

r = radius of ball bearing

η = viscosity of the oil

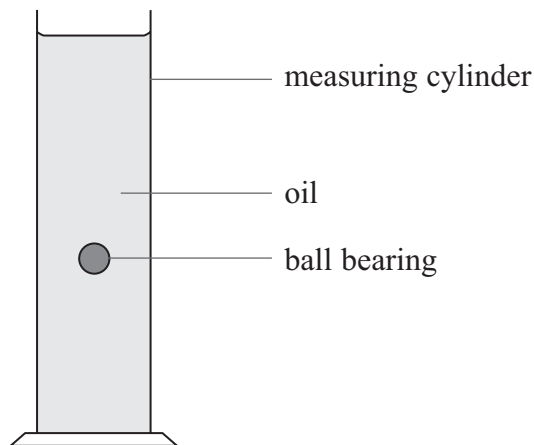

The student has been given values for the density of the oil ρ_o and the density of the ball bearings ρ_b .

Write a plan for an experiment which could be used to determine the viscosity of the oil using standard laboratory apparatus and a graphical method.

You should:

- list any additional apparatus required, you may add to the diagram if you wish, (2)
- state the quantities to be measured, (1)
- for **two** of these quantities state and explain your choice of measuring instrument, (4)
- state which is the independent and which is the dependent variable, (1)
- explain how the data collected will be used to find the viscosity, (2)
- identify the main sources of uncertainty and/or systematic error, (2)
- comment on safety. (1)



Handwriting practice area with 25 horizontal dotted lines.



Handwriting practice area with 20 horizontal dotted lines.

(Total for Question 7 = 13 marks)



- 8 In an experiment to determine the Planck constant h , a student used the apparatus shown below.

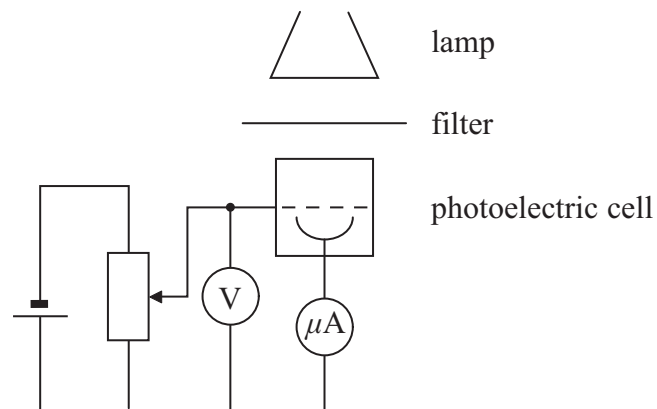

For different wavelengths of electromagnetic radiation, she adjusted the potential divider until the current was zero and then recorded the potential difference. Her results are shown below.

Wavelength/nm	Potential difference V/V
510	0.14
470	0.36
430	0.67
370	1

- (a) Criticise these results.

(2)

.....

.....

.....

.....



(b) Complete the table below by calculating the missing frequency.

(2)

Wavelength /nm	Potential difference V/V	Frequency f / 10^{14} Hz
510	0.14	5.9
470	0.36	6.4
430	0.67	
370	1	8.1

(c) Plot the values of potential difference V on the y -axis against frequency f on the x -axis on the graph paper below. Draw a straight line of best fit on your graph.

(4)

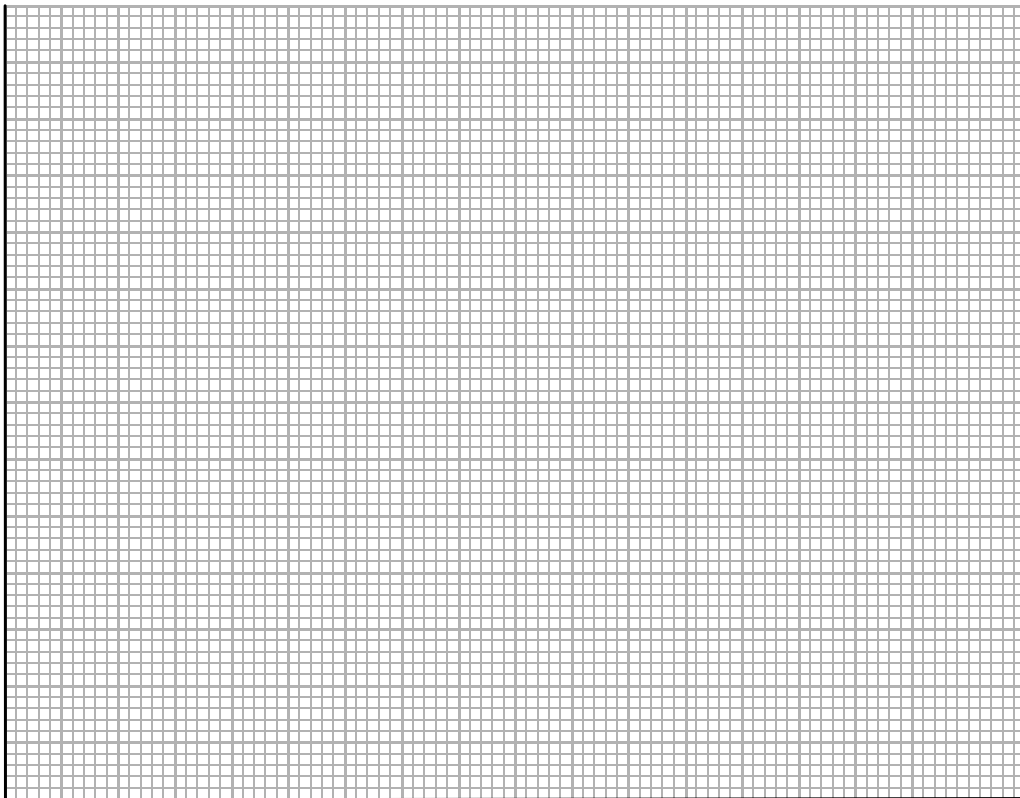

(d) The student has been given the equation

$$eV = hf - \phi$$

Explain why the graph of V against f is a straight line and how the gradient can be used to find a value for the Planck constant.

(4)

.....

.....

.....

.....

.....

.....

.....

.....

.....

.....

.....

.....

.....

.....

.....

.....

.....

.....

.....

.....

.....

.....

(e) Use the gradient of your graph to determine the Planck constant.

(3)

.....

.....

.....

.....

.....

.....

.....

.....

.....

.....

.....

.....

.....

.....

.....

.....

.....

.....

.....

.....

.....

.....



(f) Explain how you could use a graph of V against f to find a value for the constant ϕ . (2)

.....

.....

.....

.....

.....

(Total for Question 8 = 17 marks)

TOTAL FOR SECTION B = 35 MARKS

TOTAL FOR PAPER = 40 MARKS



List of data, formulae and relationships

Acceleration of free fall	$g = 9.81 \text{ m s}^{-2}$	(close to Earth's surface)
Electron charge	$e = -1.60 \times 10^{-19} \text{ C}$	
Electron mass	$m_e = 9.11 \times 10^{-31} \text{ kg}$	
Electronvolt	$1 \text{ eV} = 1.60 \times 10^{-19} \text{ J}$	
Gravitational field strength	$g = 9.81 \text{ N kg}^{-1}$	(close to Earth's surface)
Planck constant	$h = 6.63 \times 10^{-34} \text{ J s}$	
Speed of light in a vacuum	$c = 3.00 \times 10^8 \text{ m s}^{-1}$	

Unit 1*Mechanics*

Kinematic equations of motion	$v = u + at$ $s = ut + \frac{1}{2}at^2$ $v^2 = u^2 + 2as$
Forces	$\Sigma F = ma$ $g = F/m$ $W = mg$
Work and energy	$\Delta W = F\Delta s$ $E_k = \frac{1}{2}mv^2$ $\Delta E_{\text{grav}} = mg\Delta h$

Materials

Stokes' law	$F = 6\pi\eta rv$
Hooke's law	$F = k\Delta x$
Density	$\rho = m/V$
Pressure	$p = F/A$
Young modulus	$E = \sigma/\epsilon$ where Stress $\sigma = F/A$ Strain $\epsilon = \Delta x/x$
Elastic strain energy	$E_{\text{el}} = \frac{1}{2}F\Delta x$



Unit 2*Waves*

Wave speed $v = f\lambda$

Refractive index ${}_1\mu_2 = \sin i / \sin r = v_1/v_2$

Electricity

Potential difference $V = W/Q$

Resistance $R = V/I$

Electrical power, energy and efficiency
 $P = VI$
 $P = I^2R$
 $P = V^2/R$
 $W = VI t$

$$\% \text{ efficiency} = \frac{\text{useful energy output}}{\text{total energy input}} \times 100$$

$$\% \text{ efficiency} = \frac{\text{useful power output}}{\text{total power input}} \times 100$$

Resistivity $R = \rho l/A$

Current $I = \Delta Q/\Delta t$
 $I = nqvA$

Resistors in series $R = R_1 + R_2 + R_3$

Resistors in parallel $\frac{1}{R} = \frac{1}{R_1} + \frac{1}{R_2} + \frac{1}{R_3}$

Quantum physics

Photon model $E = hf$

Einstein's photoelectric equation $hf = \phi + \frac{1}{2}mv_{\max}^2$



BLANK PAGE



BLANK PAGE

