

Write your name here	
Surname	Other names
Centre Number	Candidate Number
<div style="border: 1px solid black; display: inline-block; width: 40px; height: 20px;"></div> <div style="border: 1px solid black; display: inline-block; width: 40px; height: 20px;"></div> <div style="border: 1px solid black; display: inline-block; width: 40px; height: 20px;"></div> <div style="border: 1px solid black; display: inline-block; width: 40px; height: 20px;"></div>	<div style="border: 1px solid black; display: inline-block; width: 40px; height: 20px;"></div> <div style="border: 1px solid black; display: inline-block; width: 40px; height: 20px;"></div> <div style="border: 1px solid black; display: inline-block; width: 40px; height: 20px;"></div>
<h1 style="margin: 0;">Edexcel GCE</h1> <h1 style="margin: 10px 0 0 0;">Physics</h1> <h2 style="margin: 0 0 0 0;">Advanced</h2> <h3 style="margin: 0 0 0 0;">Unit 4: Physics on the Move</h3>	
Thursday 13 June 2013 – Afternoon Time: 1 hour 35 minutes	Paper Reference 6PH04/01R
You do not need any other materials.	Total Marks

Instructions

- Use **black** ink or ball-point pen.
- **Fill in the boxes** at the top of this page with your name, centre number and candidate number.
- Answer **all** questions.
- Answer the questions in the spaces provided
– *there may be more space than you need.*

Information

- The total mark for this paper is 80.
- The marks for **each** question are shown in brackets
– *use this as a guide as to how much time to spend on each question.*
- Questions labelled with an **asterisk** (*) are ones where the quality of your written communication will be assessed
– *you should take particular care with your spelling, punctuation and grammar, as well as the clarity of expression, on these questions.*
- The list of data, formulae and relationships is printed at the end of this booklet.
- Candidates may use a scientific calculator.

Advice

- Read each question carefully before you start to answer it.
- Keep an eye on the time.
- Try to answer every question.
- Check your answers if you have time at the end.

Turn over ►

P43323A

©2013 Pearson Education Ltd.

1/1/1/



PEARSON

SECTION A

Answer ALL questions.

For questions 1–10, in Section A, select one answer from A to D and put a cross in the box . If you change your mind, put a line through the box and then mark your new answer with a cross .

- 1 A gymnast of mass 40 kg falls vertically onto a trampoline with a speed of 5 m s^{-1} and rebounds with the same speed.

She is in contact with the trampoline for 0.2 s. The average force exerted on the gymnast by the trampoline during this period is

- A 10 N
 B 20 N
 C 1000 N
 D 2000 N

(Total for Question 1 = 1 mark)

- 2 The drum of a washing machine rotates with an angular velocity of 8.5 rad s^{-1} . The time to complete 10 revolutions is

- A 0.85 s
 B 1.3 s
 C 3.7 s
 D 7.4 s

(Total for Question 2 = 1 mark)

- 3 Select the row in the table that correctly identifies what happens in an inelastic collision.

		Momentum	Kinetic energy	Total energy
<input type="checkbox"/>	A	conserved	conserved	conserved
<input type="checkbox"/>	B	not conserved	conserved	conserved
<input type="checkbox"/>	C	conserved	not conserved	conserved
<input type="checkbox"/>	D	conserved	not conserved	not conserved

(Total for Question 3 = 1 mark)



- 4 Two protons, separated by a distance x , experience a repulsive force F .
If the separation is reduced to $x/3$ the force between the protons will be

- A $F/9$
 B $F/3$
 C $3F$
 D $9F$

(Total for Question 4 = 1 mark)

- 5 The capacitor shown in the circuit below is initially charged to a potential difference (p.d.) V by closing the switch.
The power supply has negligible internal resistance.

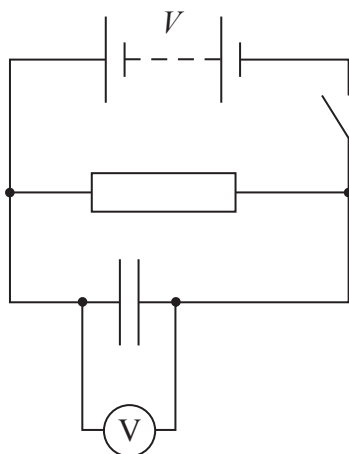

The switch is opened and the p.d. across the capacitor allowed to fall. A short time later the switch is closed again. Select the graph that shows how the p.d. across the capacitor varies with time, after the switch is opened.

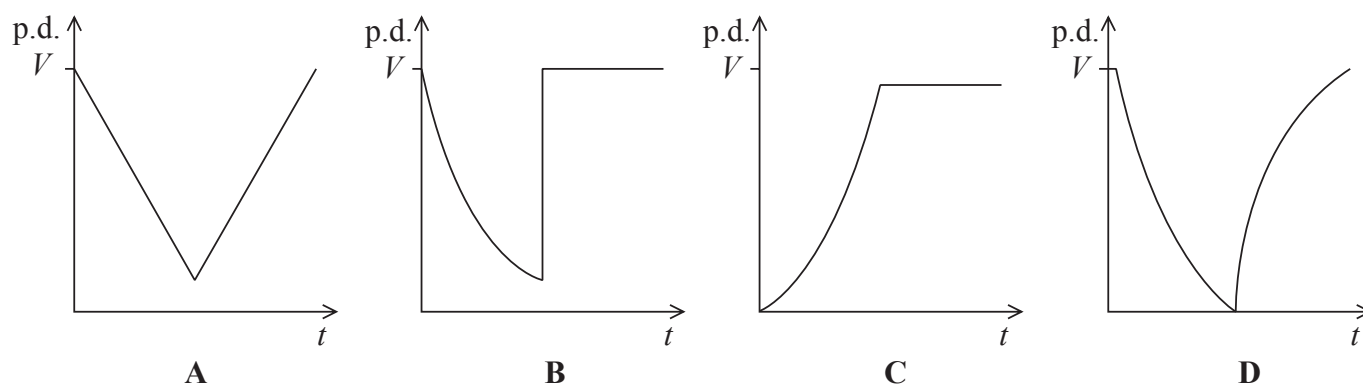

- A
 B
 C
 D

(Total for Question 5 = 1 mark)



- 6 Charged particles are travelling at a speed v , at right angles to a magnetic field of flux density B . Each particle has a mass m and a charge Q .

Which of the following changes would cause a decrease in the radius of the circular path of the particles?

- A an increase in B
- B an increase in m
- C an increase in v
- D a decrease in Q

(Total for Question 6 = 1 mark)

- 7 The de Broglie wavelength associated with electrons moving at $2.5 \times 10^6 \text{ m s}^{-1}$ is

- A $2.9 \times 10^{-4} \text{ m}$
- B $2.4 \times 10^{-8} \text{ m}$
- C $2.9 \times 10^{-10} \text{ m}$
- D $2.4 \times 10^{-39} \text{ m}$

(Total for Question 7 = 1 mark)

- 8 Which of the following is **not** a valid conclusion from Rutherford's alpha particle scattering experiment?

- A The atom is mainly empty space.
- B The mass of the atom is mostly concentrated in the nucleus.
- C The nucleus must be positively charged.
- D The nucleus must be very small compared to the atom.

(Total for Question 8 = 1 mark)



9 Select the row in the table that correctly identifies the composition of a ${}_{92}^{235}\text{U}^+$ ion.

		Number of protons	Number of neutrons	Number of electrons
<input checked="" type="checkbox"/>	A	92	143	91
<input checked="" type="checkbox"/>	B	92	143	92
<input checked="" type="checkbox"/>	C	92	235	91
<input checked="" type="checkbox"/>	D	93	235	92

(Total for Question 9 = 1 mark)

10 A transmission electron microscope passes a beam of electrons through a tiny specimen to form an image on a viewing screen.

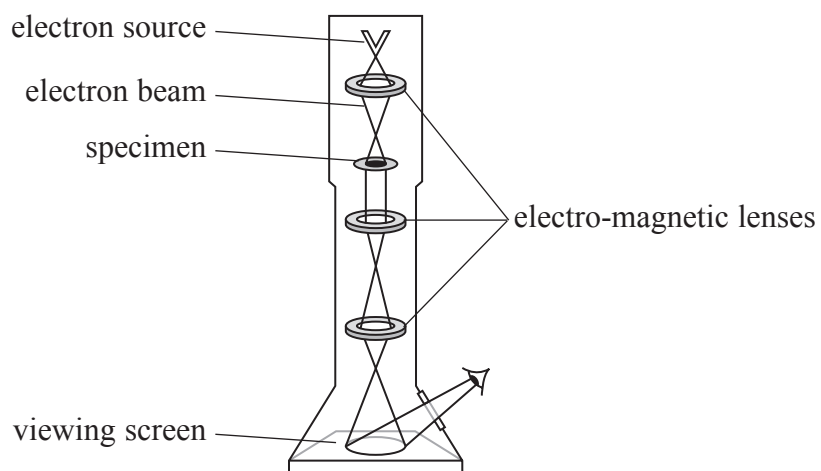

Due to the wave nature of electrons, diffraction occurs which can blur the image. To reduce this effect when viewing a smaller object the beam must contain

- A** more electrons per second.
- B** fewer electrons per second.
- C** faster moving electrons.
- D** slower moving electrons.

(Total for Question 10 = 1 mark)

TOTAL FOR SECTION A = 10 MARKS





SECTION B

Answer ALL questions in the spaces provided.

***11** The diagram shows the basic structure of a cyclotron.

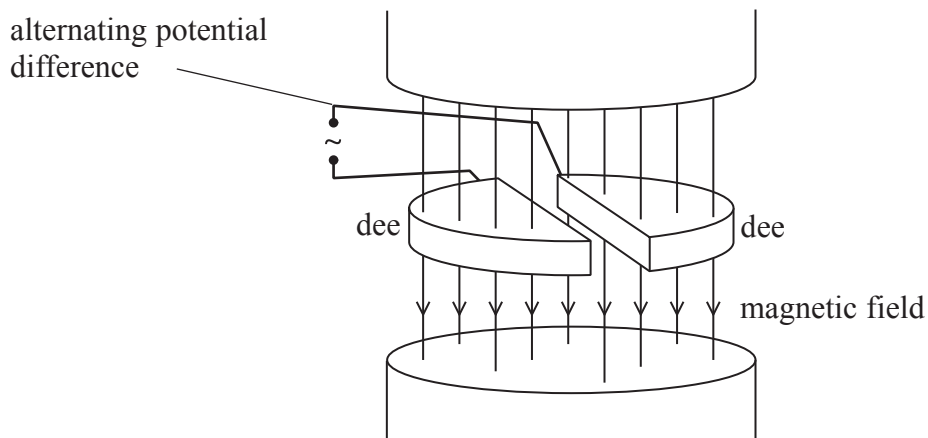

With reference to the magnetic field and the alternating potential difference explain how the cyclotron produces a beam of high speed particles.

(4)

.....

.....

.....

.....

.....

.....

.....

.....

.....

.....

.....

.....

.....

.....

.....

.....

.....

.....

.....

.....

.....

.....

.....

(Total for Question 11 = 4 marks)



*12 In 2012 Neil Armstrong, the first man to step on the moon during the Apollo 11 lunar mission, died at the age of 82.

During this mission, a planned explosion caused the separation of the module in which Armstrong was travelling and the final-stage rocket. This explosion resulted in an increase in the speed of the module.

Discuss how the conservation of momentum and the conservation of energy apply to this situation.

(5)

.....

.....

.....

.....

.....

.....

.....

.....

.....

.....

.....

.....

.....

.....

.....

.....

(Total for Question 12 = 5 marks)





13 The magnetic force F that acts on a current-carrying conductor in a magnetic field is given by the equation

$$F = BIl.$$

(a) State the condition under which this equation applies.

(1)

.....

.....

(b) The unit for magnetic flux density B is the tesla.

Express the tesla in base units.

(2)

.....

.....

.....

.....

.....



(c) The diagram shows a rectangular bar of aluminium which has a current of 5.0 A through it.

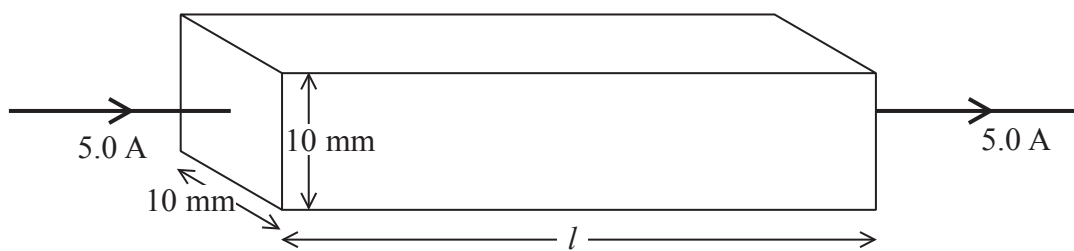

The bar is placed in a magnetic field so that its weight is supported by the magnetic field.

Calculate the minimum value of the magnetic flux density B needed for this to occur.

density of aluminium = $2.7 \times 10^3 \text{ kg m}^{-3}$

(3)

.....

.....

.....

.....

.....

.....

.....

.....

Minimum $B =$

(d) State the direction of the magnetic field.

(1)

.....

(Total for Question 13 = 7 marks)





14 Hadrons are a group of particles composed of quarks. Hadrons can be either baryons or mesons.

(a) (i) State the quark structure of a baryon.

(1)

.....

(ii) State the quark structure of a meson.

(1)

.....

(b) State **one** similarity and **one** difference between a particle and its antiparticle.

(2)

Similarity.....

.....

Difference.....

.....



(c) (i) The table gives some of the properties of up, down and strange quarks.

Type of quark	Charge/ e	Strangeness
u	$+2/3$	0
d	$-1/3$	0
s	$-1/3$	-1

One or more of these quarks combine to form a K^+ , a meson with a strangeness of +1.

Write down the quark combination of the K^+ .

(1)

(ii) The K^+ can decay in the following way

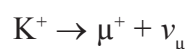

K^- is the antiparticle of the K^+ .

Complete the equation below by changing each particle to its corresponding antiparticle in order to show an allowed decay for the K^- meson.

(2)



(iii) The rest mass of the K^+ is $494 \text{ MeV}/c^2$.

Calculate, in joules, how much energy is released if a K^+ meets and annihilates a K^- .

(3)

Energy = J

(Total for Question 14 = 10 marks)



15 A particular experiment requires a very large current to be provided for a short time.

(a) An average current of 2.0×10^3 A is to be supplied to a coil of wire for a time of 1.4×10^{-3} s. The resistance of the coil is 0.50Ω .

(i) Show that the charge that flows through the coil during this time is about 3 C.

(2)

.....

.....

.....

(ii) The circuit shows how a capacitor could be charged and then discharged through the coil to provide the current.

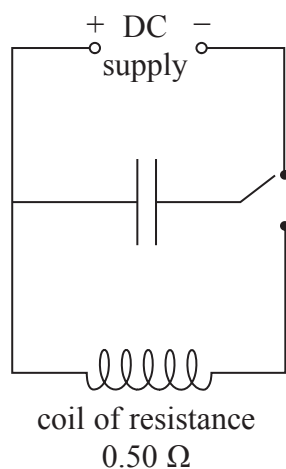

The circuit contains a capacitor of capacitance $600 \mu\text{F}$. This capacitor is suitable to provide the current for 1.4×10^{-3} s.

Explain why the capacitor is suitable.

(3)

.....

.....

.....

.....

.....

.....



(b) It can be assumed that the 600 μF capacitor completely discharges in 1.4×10^{-3} s.

(i) Calculate the potential difference of the power supply.

(2)

.....
.....
.....

Potential difference =

(ii) Calculate the average power delivered to the coil in this time.

(3)

.....
.....
.....
.....
.....
.....
.....

Average power =

(Total for Question 15 = 10 marks)





16 In order to make an object move around a circular path at a constant speed a resultant force must act on it.

(a) Explain why a resultant force is required and state the direction of this force.

(2)

.....

.....

.....

.....

.....

.....

(b) When vehicles move around a bend on a level road, the resultant force is provided by friction between the tyres and the road. For a given vehicle and road surface there is a maximum value for this sideways frictional force.

Explain why roads designed for high-speed travel, such as motorways, do not have any sharp bends.

(2)

.....

.....

.....

.....



- (c) Some cycling tracks are banked. When cornering, a cyclist moves up the track until the sideways frictional force is zero.

The free-body force diagram for a cyclist and bicycle is shown. The normal contact force exerted by the track is N and the weight of cyclist and bicycle is mg .

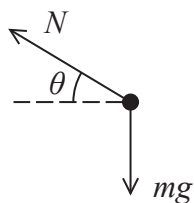

- (i) By considering the vertical and horizontal motion, show that

$$\tan \theta = gr/v^2$$

where r is the radius of the cyclist's path and v is the cyclist's speed.

(3)

.....

.....

.....

.....

.....

.....

- (ii) Calculate the value of θ for a cyclist travelling at 11.0 m s^{-1} around a bend of radius 18.7 m .

(2)

.....

$\theta =$

(Total for Question 16 = 9 marks)



17 A teacher uses an electron beam tube to demonstrate the behaviour of electrons in an electric field. The diagram shows the path of an electron in a uniform electric field between two parallel conducting plates.

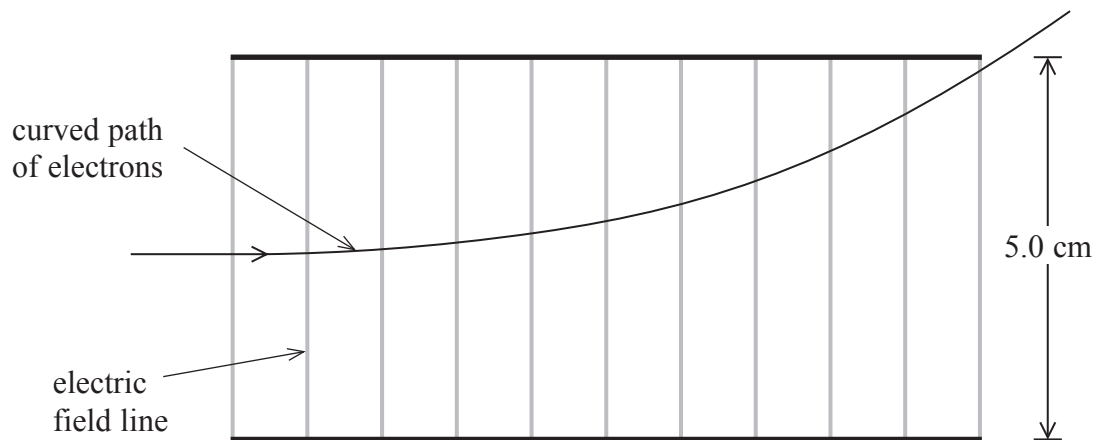

(a) Mark on the diagram the direction of the electric field. (1)

(b) The conducting plates are 5.0 cm apart and have a potential difference of 160 V across them.
Calculate the force on the electron due to the electric field. (3)

.....

.....

.....

.....

.....

Force =

(c) Explain why the path of the electron is curved between the plates and straight when it has left the plates. (3)

.....

.....

.....

.....

.....



(d) The electron was initially released from a metal by thermionic emission and then accelerated through a potential difference before entering the region of the electric field.

(i) State what is meant by thermionic emission.

(1)

.....
.....

(ii) In order to be able to just leave the plates as shown, the electron must enter the electric field between the plates with a speed of $1.2 \times 10^7 \text{ m s}^{-1}$.

Calculate the potential difference required to accelerate an electron from rest to this speed.

(3)

.....
.....
.....
.....
.....

Potential difference =

(Total for Question 17 = 11 marks)



18 The diagram shows an end view of a simple electrical generator. A rectangular coil of wire is rotated in a uniform magnetic field of magnetic flux density 3.0×10^{-2} T. The axis of rotation is at right angles to the field direction.

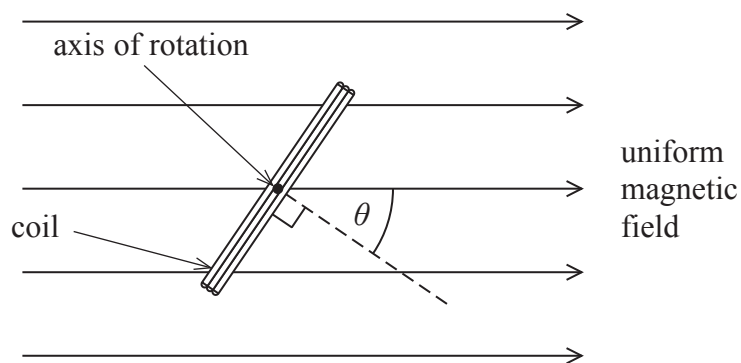

(a) The coil has 200 turns and an area of 2.0×10^{-4} m².

Calculate the magnetic flux linkage for the coil when $\theta = 0^\circ$.

(2)

.....

.....

.....

.....

.....

Flux linkage =

(b) The coil is rotated at a constant rate of 2 revolutions per second.

(i) Calculate the average e.m.f. induced in the time taken for the coil to rotate from $\theta = 0^\circ$ to $\theta = 90^\circ$.

(3)

.....

.....

.....

.....

Average e.m.f. =



(ii) The graph shows how the induced e.m.f. varies over one cycle of rotation of the coil.

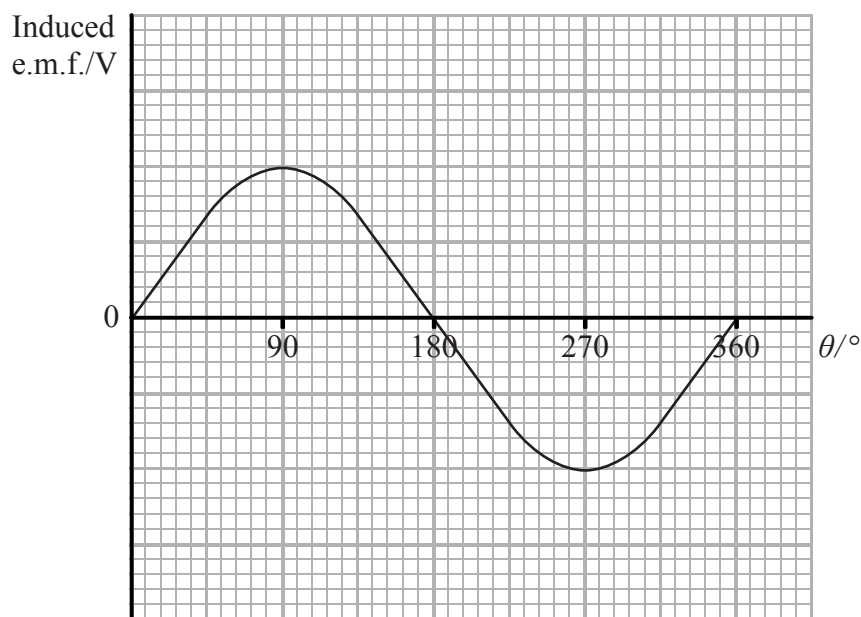

Explain why the magnitude of the e.m.f. is smallest and greatest at the values of θ shown in the graph.

(3)

.....

.....

.....

.....

.....

.....

.....

(iii) State and explain how the graph would differ if the coil rotated at a slower rate.

(2)

.....

.....

.....

.....





(c) Vehicles such as electric cars are driven by electric motors. These vehicles use regenerative braking to reduce the speed of the vehicle. The motor is operated as a generator during braking and the output from the generator is used to recharge the batteries of the car.

(i) Explain how using the motor as a generator slows the car down.

(2)

.....

.....

.....

.....

(ii) In practice, these vehicles also use friction braking as well as regenerative braking. This is because regenerative braking on its own will not fully stop a car. Suggest why.

(2)

.....

.....

.....

.....

(Total for Question 18 = 14 marks)

TOTAL FOR SECTION B = 70 MARKS

TOTAL FOR PAPER = 80 MARKS



List of data, formulae and relationships

Acceleration of free fall	$g = 9.81 \text{ m s}^{-2}$	(close to Earth's surface)
Boltzmann constant	$k = 1.38 \times 10^{-23} \text{ J K}^{-1}$	
Coulomb's law constant	$k = 1/4\pi\epsilon_0$ $= 8.99 \times 10^9 \text{ N m}^2 \text{ C}^{-2}$	
Electron charge	$e = -1.60 \times 10^{-19} \text{ C}$	
Electron mass	$m_e = 9.11 \times 10^{-31} \text{ kg}$	
Electronvolt	$1 \text{ eV} = 1.60 \times 10^{-19} \text{ J}$	
Gravitational constant	$G = 6.67 \times 10^{-11} \text{ N m}^2 \text{ kg}^{-2}$	
Gravitational field strength	$g = 9.81 \text{ N kg}^{-1}$	(close to Earth's surface)
Permittivity of free space	$\epsilon_0 = 8.85 \times 10^{-12} \text{ F m}^{-1}$	
Planck constant	$h = 6.63 \times 10^{-34} \text{ J s}$	
Proton mass	$m_p = 1.67 \times 10^{-27} \text{ kg}$	
Speed of light in a vacuum	$c = 3.00 \times 10^8 \text{ m s}^{-1}$	
Stefan-Boltzmann constant	$\sigma = 5.67 \times 10^{-8} \text{ W m}^{-2} \text{ K}^{-4}$	
Unified atomic mass unit	$u = 1.66 \times 10^{-27} \text{ kg}$	

Unit 1*Mechanics*

Kinematic equations of motion	$v = u + at$ $s = ut + \frac{1}{2}at^2$ $v^2 = u^2 + 2as$
Forces	$\Sigma F = ma$ $g = F/m$ $W = mg$
Work and energy	$\Delta W = F\Delta s$ $E_k = \frac{1}{2}mv^2$ $\Delta E_{\text{grav}} = mg\Delta h$

Materials

Stokes' law	$F = 6\pi\eta rv$
Hooke's law	$F = k\Delta x$
Density	$\rho = m/V$
Pressure	$p = F/A$
Young modulus	$E = \sigma/\epsilon$ where Stress $\sigma = F/A$ Strain $\epsilon = \Delta x/x$
Elastic strain energy	$E_{\text{el}} = \frac{1}{2}F\Delta x$



Unit 2*Waves*

Wave speed	$v = f\lambda$
Refractive index	${}_1\mu_2 = \sin i / \sin r = v_1/v_2$

Electricity

Potential difference	$V = W/Q$
Resistance	$R = V/I$
Electrical power, energy and efficiency	$P = VI$ $P = I^2R$ $P = V^2/R$ $W = VIt$
	$\% \text{ efficiency} = \frac{\text{useful energy output}}{\text{total energy input}} \times 100$
	$\% \text{ efficiency} = \frac{\text{useful power output}}{\text{total power input}} \times 100$

Resistivity	$R = \rho l/A$
Current	$I = \Delta Q/\Delta t$ $I = nqvA$
Resistors in series	$R = R_1 + R_2 + R_3$
Resistors in parallel	$\frac{1}{R} = \frac{1}{R_1} + \frac{1}{R_2} + \frac{1}{R_3}$

Quantum physics

Photon model	$E = hf$
Einstein's photoelectric equation	$hf = \phi + \frac{1}{2}mv_{\max}^2$



Unit 4*Mechanics*

Momentum	$p = mv$
Kinetic energy of a non-relativistic particle	$E_k = p^2/2m$
Motion in a circle	$v = \omega r$ $T = 2\pi/\omega$ $F = ma = mv^2/r$ $a = v^2/r$ $a = r\omega^2$

Fields

Coulomb's law	$F = kQ_1Q_2/r^2$ where $k = 1/4\pi\epsilon_0$
Electric field	$E = F/Q$ $E = kQ/r^2$ $E = V/d$
Capacitance	$C = Q/V$
Energy stored in capacitor	$W = \frac{1}{2}QV$
Capacitor discharge	$Q = Q_0e^{-t/RC}$
In a magnetic field	$F = BIl \sin \theta$ $F = Bqv \sin \theta$ $r = p/BQ$
Faraday's and Lenz's Laws	$\epsilon = -d(N\phi)/dt$

Particle physics

Mass-energy	$\Delta E = c^2 \Delta m$
de Broglie wavelength	$\lambda = h/p$





BLANK PAGE

