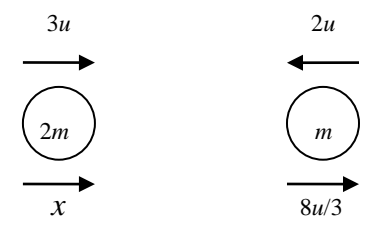
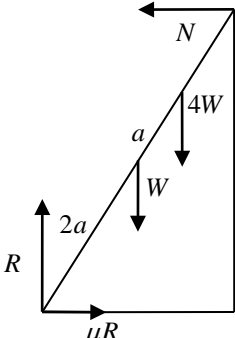

Question Number	Scheme	Marks
1.	<p>(a) Kinetic Energy = $\frac{1}{2} \times 3 \times 8^2 = 96, \text{ J}$</p> <p>(b) $F = \mu 3g$ Work-Energy $\mu 3g \times 12 = 96$ $\mu = 0.27$ or 0.272</p> <p><i>Alternative for (b)</i></p> $a = \frac{8^2 - 0^2}{2 \times 12} = \frac{8}{3}$ <p>N2L $\mu 3g = 3 \times \frac{8}{3}$</p> $\mu = 0.27$ or 0.272	<p>B1 B1 (2)</p> <p>B1 M1 A1ft A1 (4)</p> <p>B1 M1 A1 A1 (4)</p> <p>6</p>
2.	<p>(a) $\dot{\mathbf{r}} = (2t + 4)\mathbf{i} + (3 - 3t^2)\mathbf{j}$ $\dot{\mathbf{r}}_3 = 10\mathbf{i} - 24\mathbf{j}$ substituting $t = 3$ $\dot{\mathbf{r}}_3 = \sqrt{(10^2 + 24^2)} = 26 \text{ (ms}^{-1}\text{)}$</p> <p>(b) $0.4(\mathbf{v} - (10\mathbf{i} - 24\mathbf{j})) = 8\mathbf{i} - 12\mathbf{j}$ ft their $\dot{\mathbf{r}}_3$ $\mathbf{v} = 30\mathbf{i} - 54\mathbf{j} \text{ (ms}^{-1}\text{)}$</p>	<p>M1 A1 M1 M1 A1 (5)</p> <p>M1 A1ft A1 (3)</p> <p>8</p>
3.	<p>(a) $T_r = \frac{12000}{15} (= 800)$ N2L $800 - R = 1000 \times 0.2$ ft their 800 $R = 600$ * cso</p> <p>(b) $1000g \times \frac{1}{40} + T_r = R$ $T_r = \frac{7000}{U}$ $U \approx 20$ accept 19.7</p>	<p>M1 M1 A1ft A1 (4)</p> <p>M1 A1 M1 M1 A1 (5)</p> <p>9</p>

Question Number	Scheme	Marks
4.	<p>(a)</p> <div style="text-align: center;">  </div> <p>LM $6mu - 2mu = 2mx + \frac{8}{3}mu$</p> <p style="margin-left: 100px;">$\left(x = \frac{2}{3}u\right)$</p> <p>NEL $\frac{8}{3}u - x = 5ue$</p> <p style="margin-left: 100px;">Solving to $e = \frac{2}{5}$</p> <p>(b) Initial K.E. = $\frac{1}{2} \times 2m(3u)^2 + \frac{1}{2} \times m(2u)^2 = 11mu^2$</p> <p style="margin-left: 40px;">Final K.E. = $\frac{1}{2} \times 2m\left(\frac{2}{3}u\right)^2 + \frac{1}{2} \times m\left(\frac{8}{3}u\right)^2 = 4mu^2$ both</p> <p>Change in K.E. = $7mu^2$ * M1 Subtracting and simplifying to $km u^2$ A1cso</p> <p>(c) $m\left(\frac{8}{3}u + v\right) = \frac{14}{3}mu$</p> <p style="margin-left: 100px;">$(v = 2u)$</p> <p style="margin-left: 100px;">$e = \frac{2}{\frac{8}{3}} = \frac{3}{4}$</p>	<p>M1 A1</p> <p>M1 A1</p> <p>M1 A1</p> <p>(6)</p> <p>M1</p> <p>M1 A1</p> <p>(3)</p> <p>M1 A1</p> <p>M1 A1</p> <p>(4)</p> <p>13</p>

Question Number	Scheme	Marks
5.	<p>(a)</p> $12m\bar{x} = 6m \times 9$ $\bar{x} = 4\frac{1}{2}$ $12m\bar{y} = 16m - 8m$ $\bar{y} = \frac{2}{3}$ <p>(b) $(12+k)m \times 4 = 12m \times 4\frac{1}{2} + km \times 3$ ft their \bar{x}</p> $k = 6$ <p>(c) $18m \times \lambda = 12m \times \frac{2}{3}, \Rightarrow \lambda = \frac{4}{9}$</p> <p>(d) $\tan \theta = \frac{4}{4/9}, \Rightarrow \theta \approx 83.7^\circ$ ft their λ, cao</p>	<p>M1 A1 M1 A1 (4)</p> <p>M1 A1ft A1 (3)</p> <p>M1 A1 (2)</p> <p>M1 A1ft A1 (3)</p> <p>12</p>
6.	<p>(a)</p>  <p>$\uparrow R = 5W$</p> <p>M(B): $4W a \cos \theta + W \cdot 2a \cos \theta + \mu R 4a \sin \theta = R \cdot 4a \cos \theta$</p> <p>Having enough equations & solving them for μ</p> $\mu = 0.35$ <p>(b)</p> <p>$\uparrow S = (5+k)W$</p> <p>Use of $F = 0.35S$ or $F \leq 0.35S$</p> <p>M(B): $kW 4a \cos \theta + W \cdot 2a \cos \theta + F 4a \sin \theta = S \cdot 4a \cos \theta$</p> <p>Having enough equations & solving them for k</p> $k = \frac{10}{7}$ <p>awrt 1.42</p> <p>$k \square \frac{10}{7}$ ft their k, accept > and decimals</p>	<p>B1 B1 M1 A1 M1 A1 (6)</p> <p>B1 M1 M1 A1 M1 A1 A1ft (7)</p> <p>13</p>

Question Number	Scheme	Marks
7.	<p>(a) $u_x = 11 \cos 30^\circ$ $\rightarrow 11 \cos 30^\circ \times t = 10 \Rightarrow t = 1.05 \text{ (s)}$ cao</p> <p>(b) $s = 11 \sin 30^\circ \times t - 4.9t^2 \approx 0.37$ $(2-1) - 0.37 = 0.63 \text{ (m)}$</p> <p>(c) $V \cos 30^\circ \times t = 10 \quad \left(t = \frac{10}{V \cos 30^\circ} \right)$ $s = V \sin 30^\circ \times \frac{10}{V \cos 30^\circ} - \frac{4.9 \times 100}{V^2 \cos^2 \theta} = 1$ $V^2 = 136.86$ $V \approx 12$ accept 11.7</p> <p>(d) <i>B</i> and/or <i>T</i> are not particles (They have extension giving a range of answers)</p>	<p>B1 M1 A1 (3)</p> <p>B1 M1 A1 A1 (4)</p> <p>M1 A1 M1 A1 M1 A1 (6)</p> <p>B1 (1) 14</p>