



UNIVERSITY OF CAMBRIDGE INTERNATIONAL EXAMINATIONS
General Certificate of Education Advanced Level

MATHEMATICS

9709/53

Paper 5 Mechanics 2 (M2)

October/November 2012

1 hour 15 minutes

Additional Materials: Answer Booklet/Paper
Graph Paper
List of Formulae (MF9)



READ THESE INSTRUCTIONS FIRST

If you have been given an Answer Booklet, follow the instructions on the front cover of the Booklet.

Write your Centre number, candidate number and name on all the work you hand in.

Write in dark blue or black pen.

You may use a soft pencil for any diagrams or graphs.

Do not use staples, paper clips, highlighters, glue or correction fluid.

Answer **all** the questions.

Give non-exact numerical answers correct to 3 significant figures, or 1 decimal place in the case of angles in degrees, unless a different level of accuracy is specified in the question.

Where a numerical value for the acceleration due to gravity is needed, use 10 m s^{-2} .

The use of an electronic calculator is expected, where appropriate.

You are reminded of the need for clear presentation in your answers.

At the end of the examination, fasten all your work securely together.

The number of marks is given in brackets [] at the end of each question or part question.

The total number of marks for this paper is 50.

Questions carrying smaller numbers of marks are printed earlier in the paper, and questions carrying larger numbers of marks later in the paper.

This document consists of 4 printed pages.



1

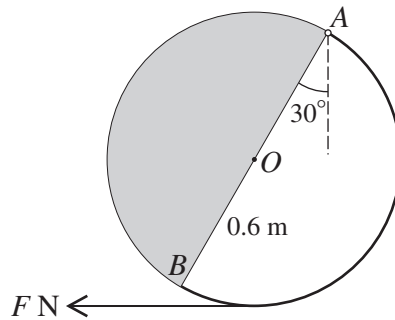

A circular object is formed from a uniform semicircular lamina of weight 12 N and a uniform semicircular arc of weight 8 N. The lamina and the arc both have centre O and radius 0.6 m and are joined at the ends of their common diameter AB . The object is freely pivoted to a fixed point at A with AB inclined at 30° to the vertical. The object is in equilibrium acted on by a horizontal force of magnitude F N applied at the lowest point of the object, and acting in the plane of the object (see diagram).

(i) Show that the centre of mass of the object is at O . [3]

(ii) Calculate F . [3]

2 A light elastic string has natural length 4 m and modulus of elasticity 60 N. A particle P of mass 0.6 kg is attached to the mid-point of the string. The ends of the string are attached to fixed points A and B which lie in the same vertical line with A at a distance of 6 m above B . P is projected vertically upwards from the point 2 m vertically above B . In the subsequent motion, P comes to instantaneous rest at a distance of 2 m below A .

(i) Calculate the speed of projection of P . [2]

(ii) Calculate the distance of P from A at an instant when P has its greatest kinetic energy, and calculate this kinetic energy. [6]

3

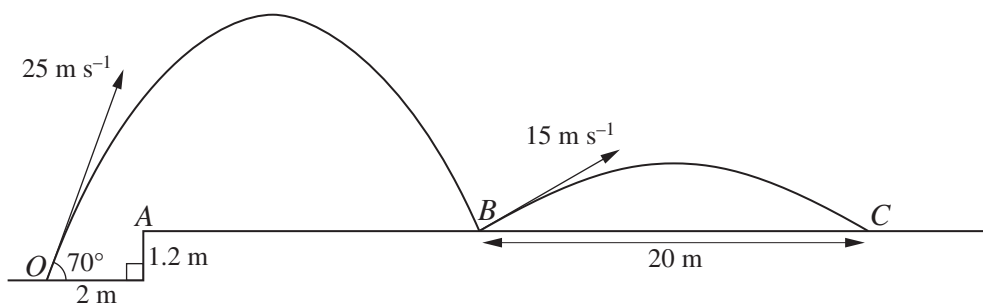

The point O is 1.2 m below rough horizontal ground ABC . A ball is projected from O with speed 25 m s^{-1} at an angle of 70° to the horizontal. The ball passes over the point A after travelling a horizontal distance of 2 m. The ball subsequently bounces once on the ground at B . The ball leaves B with speed 15 m s^{-1} and travels a further horizontal distance of 20 m before landing at C (see diagram).

(i) Calculate the height above the level of O of the ball when it is vertically above A . [3]

(ii) Calculate the time after the instant of projection when the ball reaches B . [3]

(iii) Find the angle which the trajectory of the ball makes with the horizontal immediately after it bounces at B . [2]

4

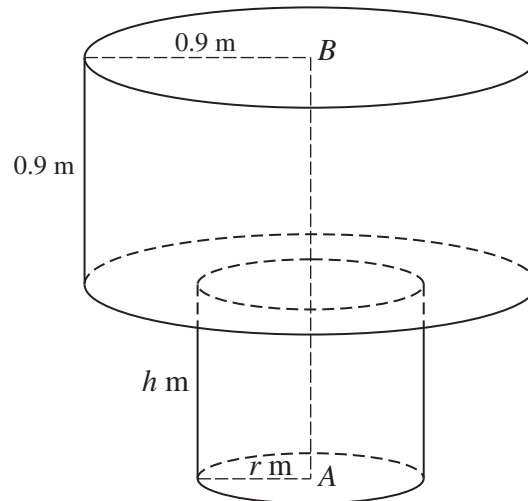

A cylinder of height 0.9 m and radius 0.9 m is placed symmetrically on top of a cylinder of height h m and radius r m, where $r < 0.9$, with plane faces in contact and axes in the same vertical line AB , where A and B are centres of plane faces of the cylinders (see diagram). Both cylinders are uniform and made of the same material. The lower cylinder is gradually tilted and when the axis of symmetry is inclined at 45° to the horizontal the upper cylinder is on the point of toppling without sliding.

- (i) Find r . [2]

The upper cylinder is now fixed to the lower cylinder to create a uniform object.

- (ii) Show that the centre of mass of the object is

$$\frac{25h^2 + 180h + 81}{50h + 180} \text{ m}$$

from A . [3]

The object is placed with the plane face containing A in contact with a rough plane inclined at α° to the horizontal, where $\tan \alpha = 0.5$. The object is on the point of toppling without sliding.

- (iii) Calculate h . [3]

- 5 A small ball B of mass 0.2 kg is attached to fixed points P and Q by two light inextensible strings of equal length. P is vertically above Q , the strings are taut and each is inclined at 60° to the vertical. B moves with constant speed in a horizontal circle of radius 0.6 m.

- (i) Given that the tension in the string PB is 7 N, calculate
- (a) the tension in string QB , [2]
- (b) the speed of B . [3]
- (ii) Given instead that B is moving with angular speed 7 rad s^{-1} , calculate the tension in the string QB . [4]

[Question 6 is printed on the next page.]

6



Two particles P and Q , of masses 0.4 kg and 0.2 kg respectively, are attached to opposite ends of a light inextensible string. P is placed on a horizontal table and the string passes over a small smooth pulley at the edge of the table. The string is taut and the part of the string attached to Q is vertical (see diagram). The coefficient of friction between P and the table is 0.5 . Q is projected vertically downwards with speed 5 m s^{-1} , and at time $t\text{ s}$ after the instant of projection the speed of the particles is $v\text{ m s}^{-1}$. The motion of each particle is opposed by a resisting force of magnitude $0.9v\text{ N}$. The particle P does not reach the pulley.

(i) Show that $\frac{dv}{dt} = -3v$. [4]

(ii) Find the value of t when the particles have speed 2.5 m s^{-1} and the distance that each particle has travelled in this time. [7]

Permission to reproduce items where third-party owned material protected by copyright is included has been sought and cleared where possible. Every reasonable effort has been made by the publisher (UCLES) to trace copyright holders, but if any items requiring clearance have unwittingly been included, the publisher will be pleased to make amends at the earliest possible opportunity.

University of Cambridge International Examinations is part of the Cambridge Assessment Group. Cambridge Assessment is the brand name of University of Cambridge Local Examinations Syndicate (UCLES), which is itself a department of the University of Cambridge.