



Cambridge International AS & A Level

PHYSICS

9702/13

Paper 1 Multiple Choice

October/November 2021

1 hour 15 minutes

You must answer on the multiple choice answer sheet.

You will need: Multiple choice answer sheet
Soft clean eraser
Soft pencil (type B or HB is recommended)

INSTRUCTIONS

- There are **forty** questions on this paper. Answer **all** questions.
- For each question there are four possible answers **A, B, C** and **D**. Choose the **one** you consider correct and record your choice in soft pencil on the multiple choice answer sheet.
- Follow the instructions on the multiple choice answer sheet.
- Write in soft pencil.
- Write your name, centre number and candidate number on the multiple choice answer sheet in the spaces provided unless this has been done for you.
- Do **not** use correction fluid.
- Do **not** write on any bar codes.
- You may use a calculator.

INFORMATION

- The total mark for this paper is 40.
- Each correct answer will score one mark.
- Any rough working should be done on this question paper.

This document has **20** pages. Any blank pages are indicated.



Data

| | |
|------------------------------|--|
| speed of light in free space | $c = 3.00 \times 10^8 \text{ m s}^{-1}$ |
| permeability of free space | $\mu_0 = 4\pi \times 10^{-7} \text{ H m}^{-1}$ |
| permittivity of free space | $\epsilon_0 = 8.85 \times 10^{-12} \text{ F m}^{-1}$ $(\frac{1}{4\pi\epsilon_0} = 8.99 \times 10^9 \text{ m F}^{-1})$ |
| elementary charge | $e = 1.60 \times 10^{-19} \text{ C}$ |
| the Planck constant | $h = 6.63 \times 10^{-34} \text{ J s}$ |
| unified atomic mass unit | $1 \text{ u} = 1.66 \times 10^{-27} \text{ kg}$ |
| rest mass of electron | $m_e = 9.11 \times 10^{-31} \text{ kg}$ |
| rest mass of proton | $m_p = 1.67 \times 10^{-27} \text{ kg}$ |
| molar gas constant | $R = 8.31 \text{ J K}^{-1} \text{ mol}^{-1}$ |
| the Avogadro constant | $N_A = 6.02 \times 10^{23} \text{ mol}^{-1}$ |
| the Boltzmann constant | $k = 1.38 \times 10^{-23} \text{ J K}^{-1}$ |
| gravitational constant | $G = 6.67 \times 10^{-11} \text{ N m}^2 \text{ kg}^{-2}$ |
| acceleration of free fall | $g = 9.81 \text{ m s}^{-2}$ |

Formulae

| | |
|--------------------------------|--|
| uniformly accelerated motion | $s = ut + \frac{1}{2}at^2$ $v^2 = u^2 + 2as$ |
| work done on/by a gas | $W = p\Delta V$ |
| gravitational potential | $\phi = -\frac{Gm}{r}$ |
| hydrostatic pressure | $p = \rho gh$ |
| pressure of an ideal gas | $p = \frac{1}{3}\frac{Nm}{V}\langle c^2 \rangle$ |
| simple harmonic motion | $a = -\omega^2 x$ |
| velocity of particle in s.h.m. | $v = v_0 \cos \omega t$ $v = \pm \omega \sqrt{(x_0^2 - x^2)}$ |
| Doppler effect | $f_o = \frac{f_s v}{v \pm v_s}$ |
| electric potential | $V = \frac{Q}{4\pi\epsilon_0 r}$ |
| capacitors in series | $1/C = 1/C_1 + 1/C_2 + \dots$ |
| capacitors in parallel | $C = C_1 + C_2 + \dots$ |
| energy of charged capacitor | $W = \frac{1}{2}QV$ |
| electric current | $I = Anvq$ |
| resistors in series | $R = R_1 + R_2 + \dots$ |
| resistors in parallel | $1/R = 1/R_1 + 1/R_2 + \dots$ |
| Hall voltage | $V_H = \frac{BI}{ntq}$ |
| alternating current/voltage | $x = x_0 \sin \omega t$ |
| radioactive decay | $x = x_0 \exp(-\lambda t)$ |
| decay constant | $\lambda = \frac{0.693}{t_{\frac{1}{2}}}$ |

- 1 A paperback book contains 210 sheets of paper (pages). Its thickness is measured with a ruler, as shown.

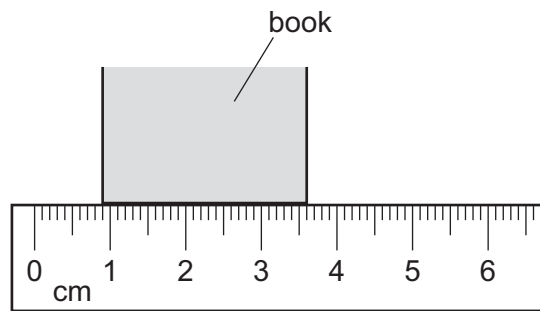

What is the average thickness of one sheet of the paper in the book?

- A** 0.013 mm **B** 0.017 mm **C** 0.13 mm **D** 0.17 mm
- 2 What is the unit of resistance when expressed in SI base units?
- A** $\text{kg}^{-1} \text{m}^{-2} \text{sA}^2$
B $\text{kg}^{-1} \text{m}^{-2} \text{s}^3 \text{A}^2$
C $\text{kgm}^2 \text{s}^{-1} \text{A}^{-2}$
D $\text{kgm}^2 \text{s}^{-3} \text{A}^{-2}$
- 3 Which list consists only of scalar quantities?
- A** acceleration, displacement, force, weight
B density, energy, frequency, velocity
C distance, pressure, temperature, time
D momentum, power, volume, wavelength

- 4 The output of a signal generator is connected to a cathode-ray oscilloscope (CRO). A trace is shown on the screen.

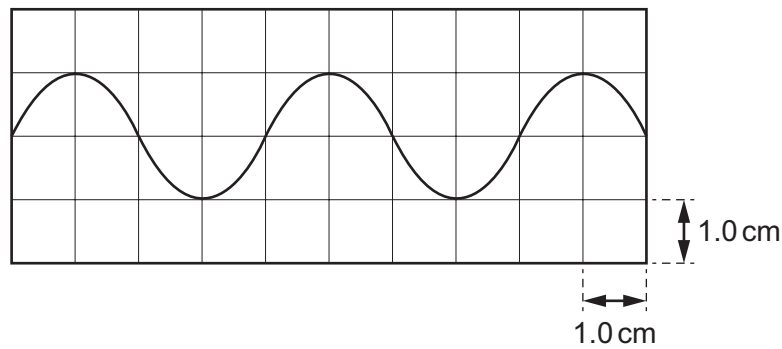

The time-base of the CRO is set at 2.00 ms cm^{-1} .

What is the frequency of the signal?

- A** 50 Hz **B** 125 Hz **C** 250 Hz **D** 500 Hz
- 5 After measuring the width of a shelf to be 305 mm, it is found that the graduations on the ruler used are 1.0% further apart than they should be.

Which type of measurement error is this and what is the true width of the shelf?

| | type of error | true width / mm |
|----------|---------------|-----------------|
| A | random | 302 |
| B | random | 308 |
| C | systematic | 302 |
| D | systematic | 308 |

- 6 The graph shows the variation with time of the acceleration of a car.

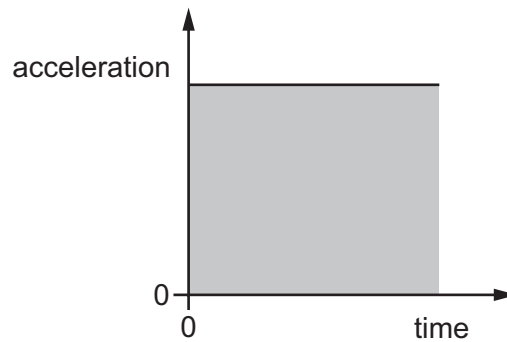

What **must** the shaded area under the graph represent?

- A the average velocity of the car
 - B the change in velocity of the car
 - C the final velocity of the car
 - D the initial velocity of the car
- 7 A stone is thrown horizontally off a cliff and then lands in the sea. Air resistance is negligible.
- Which statement about the stone's motion is **not** correct?
- A The final displacement of the stone depends upon its initial horizontal velocity.
 - B The stone travels with a constant horizontal component of velocity until it hits the water.
 - C The stone travels with an increasing vertical component of velocity.
 - D The time taken for the stone to hit the surface of the water depends on its initial horizontal velocity.
- 8 Water is pumped through a hose-pipe at a rate of 90 kg per minute. Water emerges horizontally from the hose-pipe with a speed of 20 m s^{-1} .
- What is the minimum force required from a person holding the hose-pipe to prevent it moving backwards?
- A 30 N B 270 N C 1800 N D 110 000 N

- 9 A skydiver leaves a stationary balloon and falls vertically through a long distance.

Which graph best represents the variation of the acceleration a of the skydiver with the distance s travelled as she falls through the air?

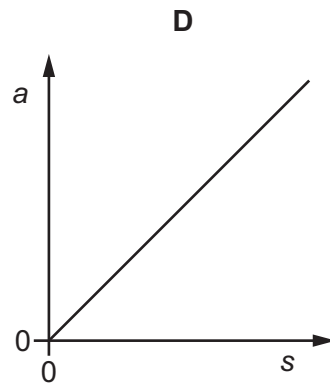
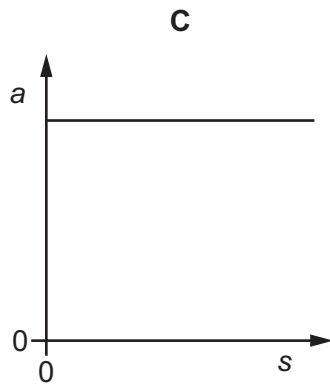
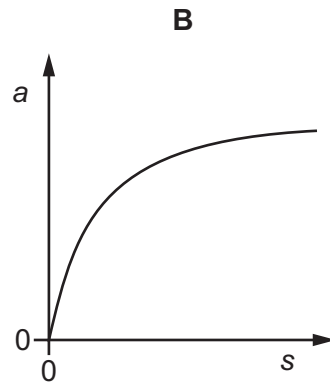
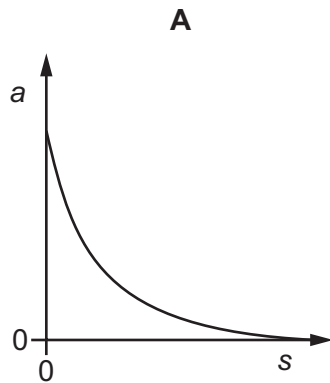

- 10 The diagram shows two spheres approaching each other head-on. Each sphere has speed u . One sphere has mass $2m$ and the other has mass m .



Which diagram shows the result of a perfectly elastic collision?

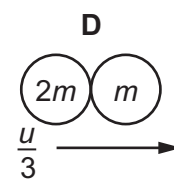
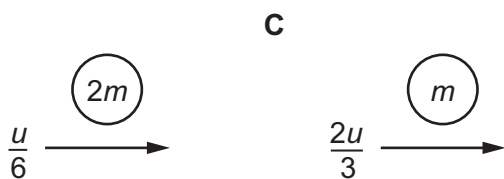
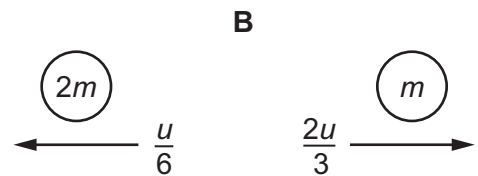
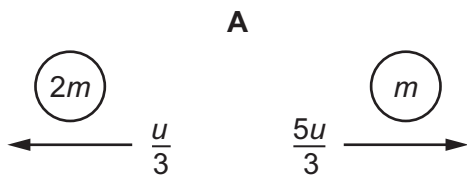

the spheres stick together

11 A spherical object falls through water at a constant speed. Three forces act on the object.

Which diagram, showing these three forces to scale, is correct?

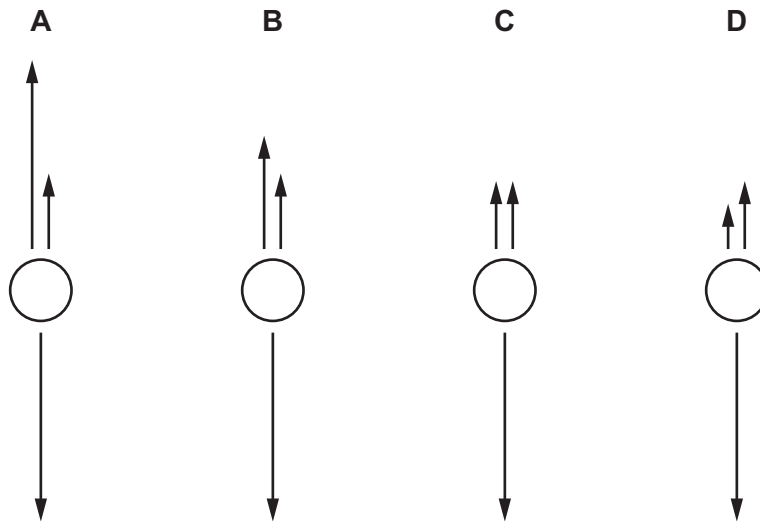

12 Two forces act as a couple.

Which statement about the two forces must **not** be correct?

- A They act along the same straight line.
- B They act in opposite directions.
- C They are the same type of force.
- D They have the same magnitude.

13 A sign outside a shop is suspended from a rusty horizontal hinge at its top end. The sign hangs in equilibrium at an angle of 25° to the vertical, as shown.

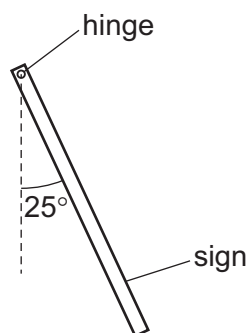

The sign is a square of side length 52 cm and uniform thickness. It has a mass of 36 kg.

What is the moment of the weight of the sign about the hinge?

- A 39 Nm
- B 78 Nm
- C 83 Nm
- D 92 Nm

- 14 A uniform rod of length 200 cm is freely pivoted at point P. The rod is held horizontally in equilibrium by a 60 N weight that is attached to the rod by a string passing over a frictionless pulley.

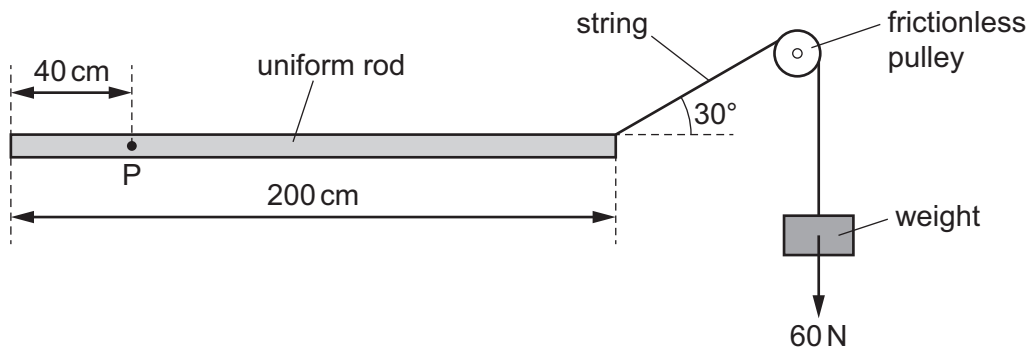

What is the weight of the rod?

- A 30 N B 60 N C 80 N D 140 N
- 15 The diagram shows two blocks X and Y.

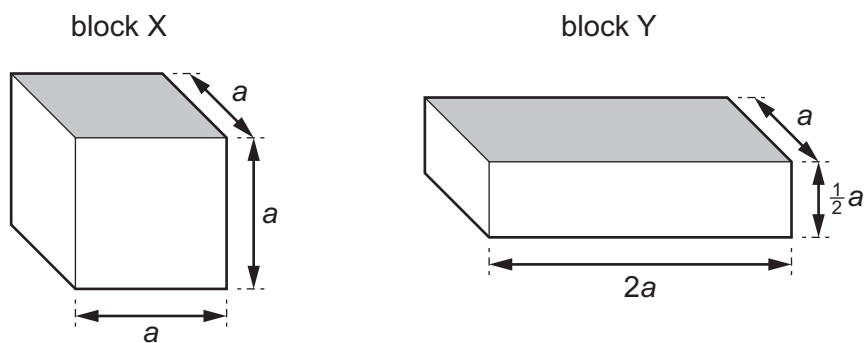

Block X has sides of length a . When block X is placed in a liquid of density ρ with the shaded face level with the liquid surface, it experiences an upthrust U .

Block Y has horizontal sides of length a and $2a$ and height $\frac{1}{2}a$. Block Y is placed in a liquid of density 2ρ , also with the shaded face level with the liquid surface.

What is the upthrust on block Y?

- A $\frac{1}{2}U$ B U C $2U$ D $4U$

- 16 A gas is contained inside a syringe, as shown.

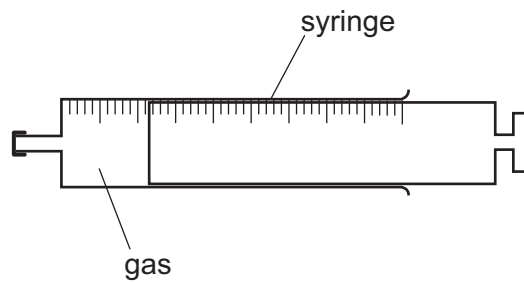

The initial volume of the gas is 2.00 cm^3 .

Atmospheric pressure is 101 kPa .

What is the work done by the gas on the atmosphere when the gas is heated and expands to a volume of 6.00 cm^3 ?

- A $404 \mu\text{J}$ B 404 mJ C 404 J D 404 kJ
- 17 A mechanical device does useful work at rate X and wastes energy at rate Y .

Which expression gives the efficiency of this device?

- A $\frac{X}{Y}$ B $\frac{(X-Y)}{Y}$ C $\frac{X}{(X+Y)}$ D $\frac{(X-Y)}{(X+Y)}$

- 18 Car P has kinetic energy 240 kJ .

Car Q has half the mass and twice the speed of car P.

What is the kinetic energy of car Q?

- A 120 kJ B 240 kJ C 480 kJ D 960 kJ
- 19 A water pump is driven by an engine. The pump raises a volume of 0.50 m^3 of water in 1.0 minute from a depth of 30 m . The pump has an efficiency of 70% .

The density of water is 1000 kg m^{-3} .

What is the useful output power from the engine?

- A 2.5 kW B 3.5 kW C 150 kW D 210 kW

20 Which spring combination has an overall spring constant of 8.0 N m^{-1} ?

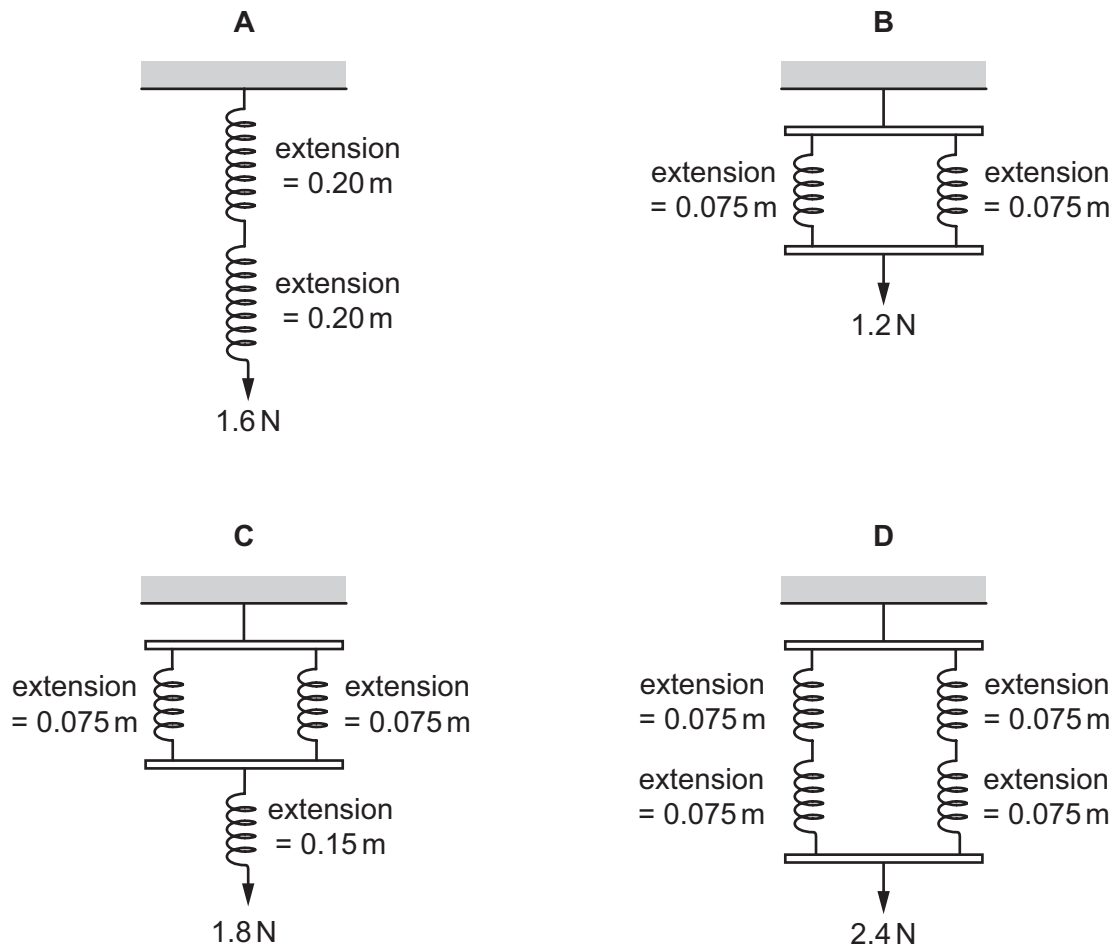

21 A metal wire is stretched to breaking point and the force–extension graph is plotted.

Which graph is correctly labelled with the elastic region, the plastic region and the area representing the work done to stretch the wire until it breaks?

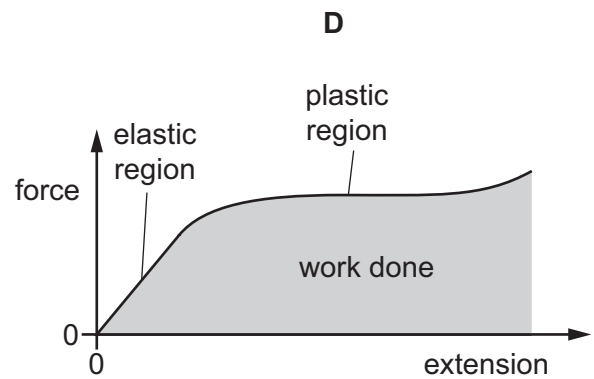
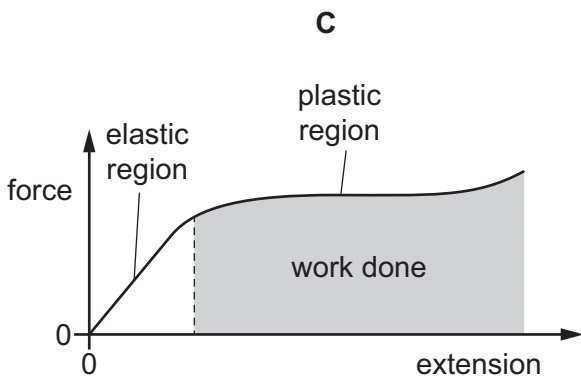
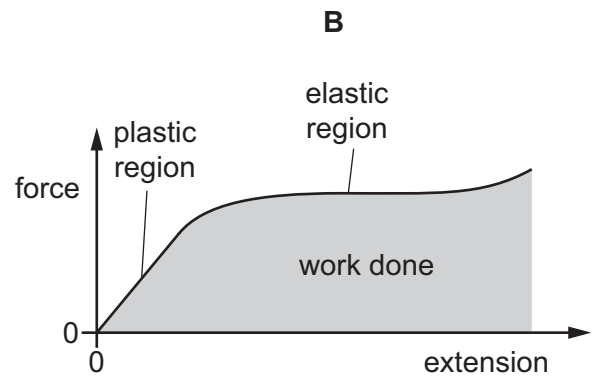
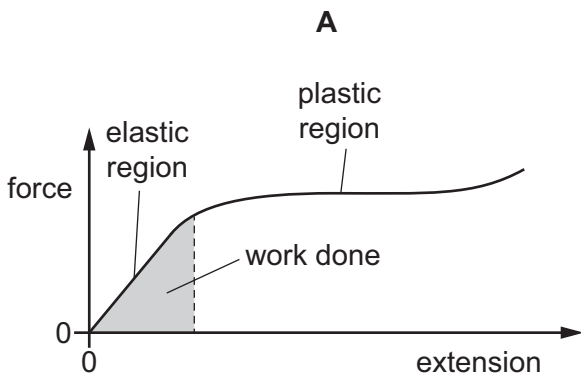

22 A longitudinal wave travels through a long spring. The spring is shown at one instant.

What is the wavelength of the wave?

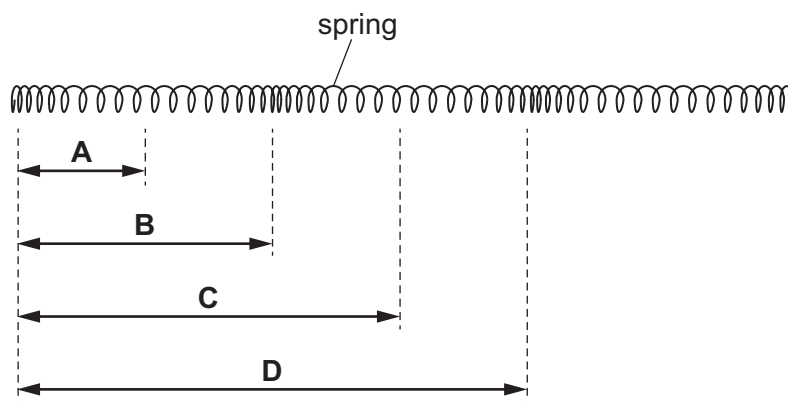

23 Which statement about waves is correct?

- A Both longitudinal and transverse waves can travel through a vacuum.
- B Both longitudinal and transverse waves transfer matter.
- C Longitudinal progressive waves consist of alternate nodes and antinodes.
- D The particles of a transverse wave vibrate perpendicular to the direction of energy propagation.

24 A stationary sound wave is formed in a pipe that is closed at one end and open at the other end. The wave has two antinodes. One of these antinodes is at the open end of the pipe.

The length of the pipe is 0.600 m. The speed of sound in the air column in the pipe is 340 m s^{-1} .

What is the frequency of the sound wave?

- A 425 Hz B 850 Hz C 1130 Hz D 2270 Hz

25 A train travels at constant speed along a straight track. The train's horn emits sound of frequency 500 Hz.

A person standing by the side of the track hears sound of frequency 450 Hz.

The speed of sound in air is 340 m s^{-1} .

What is the speed of the train and in which direction is it travelling relative to the person?

| | speed / m s^{-1} | direction |
|----------|---------------------------|----------------------|
| A | 34 | away from the person |
| B | 34 | towards the person |
| C | 38 | away from the person |
| D | 38 | towards the person |

26 A smooth surface has bumps on the surface that are smaller than the wavelength of visible light.

What is the approximate maximum size of the largest bumps on the surface?

- A 20 nm B 350 nm C 720 nm D $5.0 \mu\text{m}$

- 27 Two progressive waves travel in opposite directions and form a stationary wave. The graph shows the variation with distance x of the displacement of the stationary wave and of one of the two progressive waves at the same instant in time.

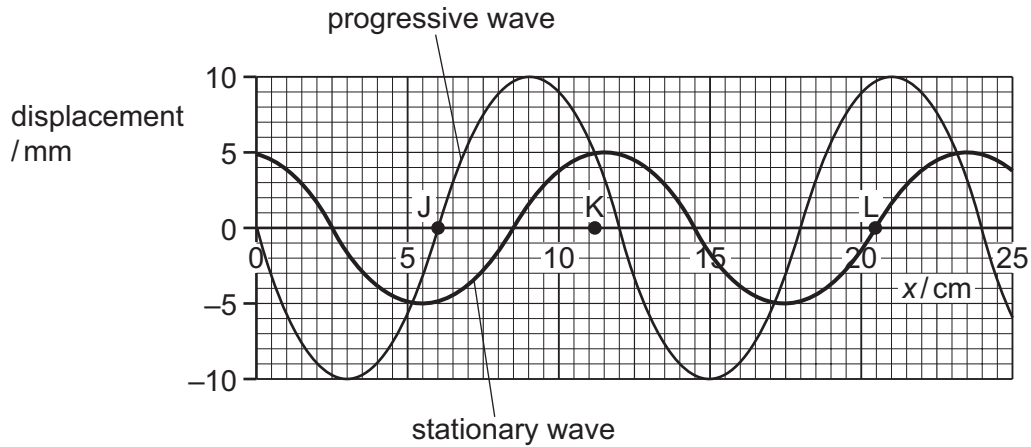

What are the approximate displacements of the **other** progressive wave at the positions J, K and L?

| | displacement / mm | | |
|----------|-------------------|----|-----|
| | J | K | L |
| A | -5 | 0 | -10 |
| B | -5 | +5 | 0 |
| C | 0 | +5 | +10 |
| D | +5 | -5 | 0 |

- 28 Which diagram shows the diffraction of water waves in a ripple tank?

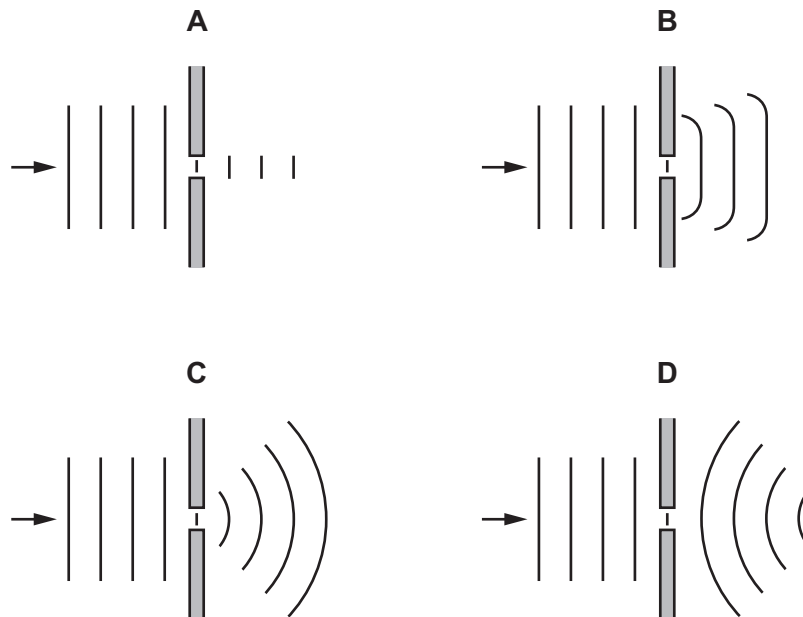

- 29 Interference fringes are produced on a screen by double-slit interference using light of wavelength 600 nm. The fringe separation is 4.0 mm and the separation of the slits is 0.60 mm.

What is the distance between the double slit and the screen?

- A 0.25 m B 0.40 m C 2.5 m D 4.0 m

- 30 A ray of green light is incident normally on a diffraction grating. Several bright spots are produced on a screen on the other side of the grating, as shown.

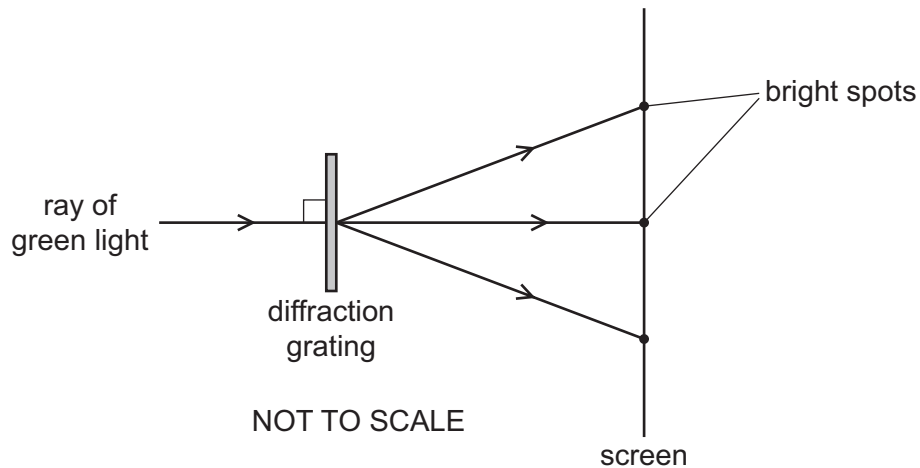

Which pair of changes could result in bright spots at exactly the same angles as previously?

- A Use blue light and increase the distance between the grating and the screen.
B Use blue light and increase the number of lines per unit length in the grating.
C Use red light and increase the distance between the grating and the screen.
D Use red light and increase the number of lines per unit length in the grating.

31 Two parallel metal plates are at electric potentials of +800 V and +1300 V.

Which diagram best represents the electric field between the metal plates?

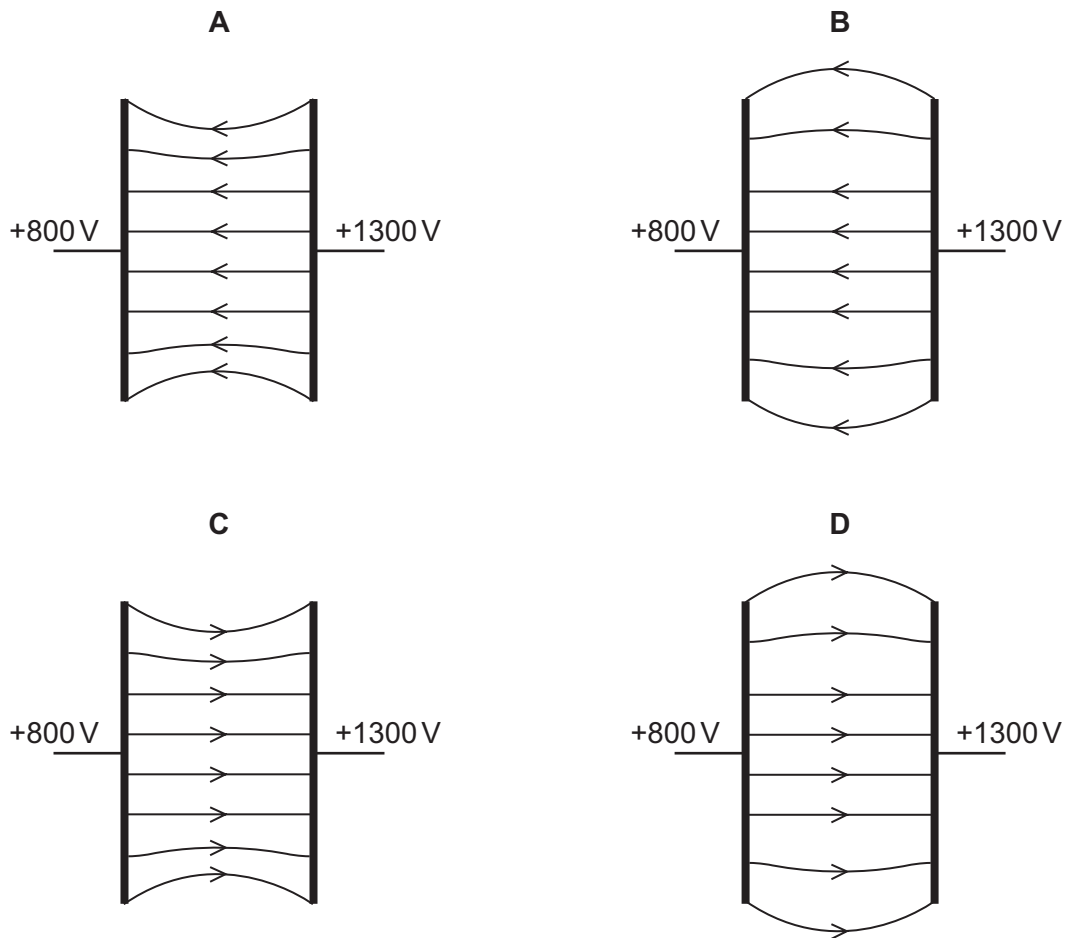

32 An electron is in a uniform electric field of field strength 1500 V m^{-1} .

What is the acceleration of the electron due to the electric field?

- A $8.5 \times 10^{-9} \text{ ms}^{-2}$
- B $1.6 \times 10^{-5} \text{ ms}^{-2}$
- C $1.4 \times 10^{11} \text{ ms}^{-2}$
- D $2.6 \times 10^{14} \text{ ms}^{-2}$

33 A lightning strike transfers 1×10^{20} electrons past a point in a time of $30 \mu\text{s}$.

What is the average current during the lightning strike?

- A 0.5 mA
- B 0.5 A
- C 500 A
- D 500 kA

- 34 A cell has an electromotive force (e.m.f.) of 6V and internal resistance R . An external resistor, also of resistance R , is connected across this cell, as shown.

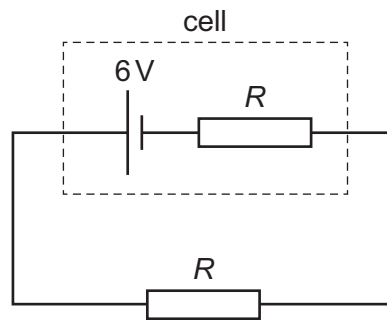

Power P is dissipated by the external resistor.

The cell is replaced by a different cell that has an e.m.f. of 6V and negligible internal resistance.

What is the new power that is dissipated in the external resistor?

- A $0.5P$ B P C $2P$ D $4P$
- 35 A wire of uniform cross-section has resistance R .

A second wire is made of the same material but is twice as long and has twice the diameter of the first wire.

What is the resistance of the second wire?

- A $\frac{R}{8}$ B $\frac{R}{2}$ C R D $8R$

- 36 The diagram shows two resistor networks.

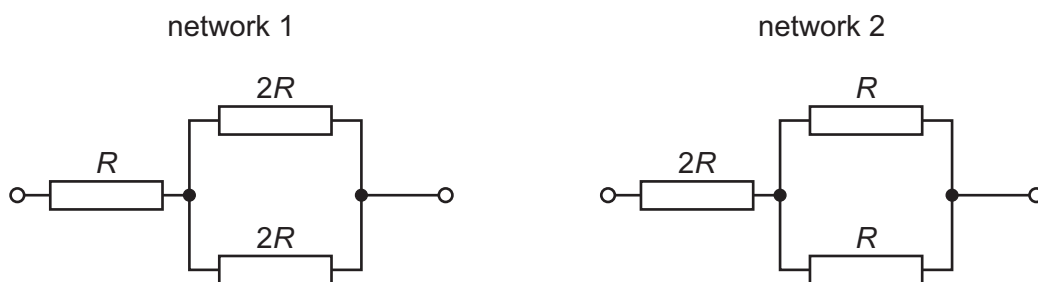

What is the ratio $\frac{\text{total resistance of network 1}}{\text{total resistance of network 2}}$?

- A $\frac{4}{5}$ B $\frac{5}{4}$ C $\frac{1}{2}$ D $\frac{2}{1}$

- 37 The circuit shown contains three cells of electromotive forces 3.0V, 2.0V and 4.0V, in series with a resistor of resistance 5.0Ω . The cells have negligible internal resistance.

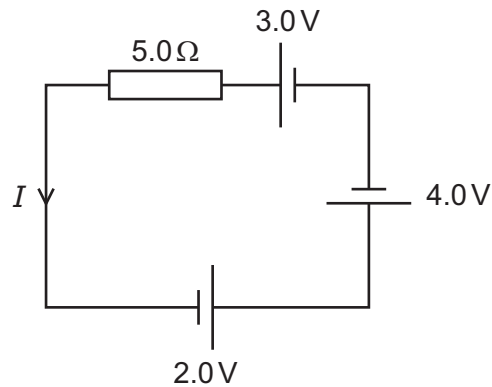

What is the current I in the circuit?

- A** 0.20 A **B** 0.60 A **C** 1.0 A **D** 1.8 A
- 38 When α -particles are fired at a thin metal foil, most of the particles pass straight through but a few are deflected by a large angle.

Which change would increase the **proportion** of α -particles deflected by a large angle?

- A** using α -particles with greater kinetic energy
B using a double thickness foil
C using a foil made of a metal with fewer protons in its nuclei
D using a source emitting more α -particles per unit time

39 A nucleus of neptunium-236 contains 93 protons and 143 neutrons. This nucleus decays with the emission of an α -particle. The nucleus formed then emits a β^- particle.

Which diagram shows the changes in the number P of protons and the number N of neutrons in these nuclei?

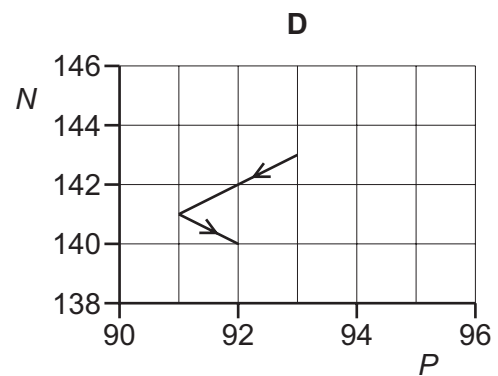
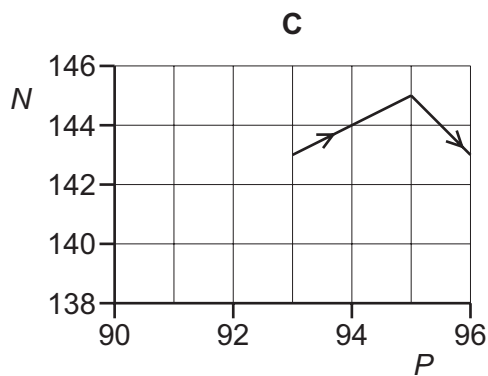
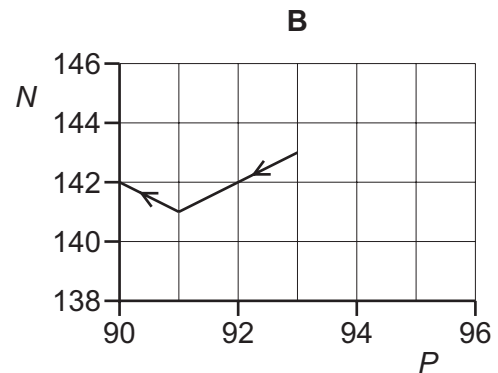
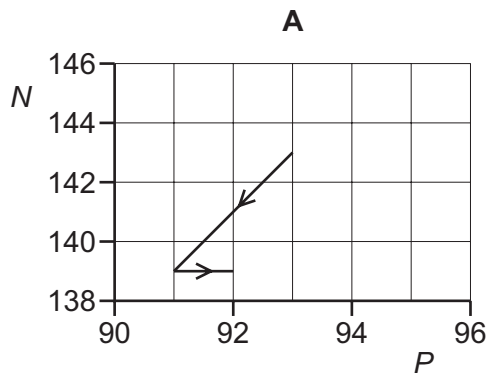

40 Which combination of quarks could **not** be the quark composition of the hadron shown?

p = proton

n = neutron

Σ^- = sigma particle of charge $-e$

Σ^+ = sigma particle of charge $+e$

u = up quark

d = down quark

s = strange quark

| | hadron | quark composition |
|----------|------------|-------------------|
| A | Σ^- | dds |
| B | Σ^+ | uds |
| C | p | uud |
| D | n | udd |

BLANK PAGE

Permission to reproduce items where third-party owned material protected by copyright is included has been sought and cleared where possible. Every reasonable effort has been made by the publisher (UCLES) to trace copyright holders, but if any items requiring clearance have unwittingly been included, the publisher will be pleased to make amends at the earliest possible opportunity.

To avoid the issue of disclosure of answer-related information to candidates, all copyright acknowledgements are reproduced online in the Cambridge Assessment International Education Copyright Acknowledgements Booklet. This is produced for each series of examinations and is freely available to download at www.cambridgeinternational.org after the live examination series.

Cambridge Assessment International Education is part of the Cambridge Assessment Group. Cambridge Assessment is the brand name of the University of Cambridge Local Examinations Syndicate (UCLES), which itself is a department of the University of Cambridge.