

Cambridge  
International  
AS & A Level

**Cambridge Assessment International Education**  
Cambridge International Advanced Subsidiary and Advanced Level

CANDIDATE  
NAME

CENTRE  
NUMBER

|  |  |  |  |  |  |
|--|--|--|--|--|--|
|  |  |  |  |  |  |
|--|--|--|--|--|--|

CANDIDATE  
NUMBER

|  |  |  |  |
|--|--|--|--|
|  |  |  |  |
|--|--|--|--|

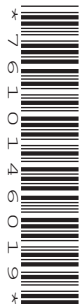

**PHYSICS**

**9702/31**

Paper 3 Advanced Practical Skills 1

**October/November 2019**

**2 hours**

Candidates answer on the Question Paper.

Additional Materials: As listed in the Confidential Instructions.

**READ THESE INSTRUCTIONS FIRST**

Write your centre number, candidate number and name on all the work you hand in.

Write in dark blue or black pen.

You may use an HB pencil for any diagrams or graphs.

Do not use staples, paper clips, glue or correction fluid.

DO **NOT** WRITE IN ANY BARCODES.

Answer **both** questions.

You will be allowed to work with the apparatus for a maximum of one hour for each question.

You are expected to record all your observations as soon as these observations are made, and to plan the presentation of the records so that it is not necessary to make a fair copy of them.

You are reminded of the need for good English and clear presentation in your answers.

Electronic calculators may be used.

You may lose marks if you do not show your working or if you do not use appropriate units.

Additional answer paper and graph paper should be used only if it becomes necessary to do so.

At the end of the examination, fasten all your work securely together.

The number of marks is given in brackets [ ] at the end of each question or part question.

| For Examiner's Use |  |
|--------------------|--|
| 1                  |  |
| 2                  |  |
| <b>Total</b>       |  |

This document consists of **12** printed pages.

You may not need to use all of the materials provided.

1 In this experiment, you will investigate an electrical circuit.

- (a)
- Place the  $10\ \Omega$  resistor in component holder P.
  - Place the  $22\ \Omega$  resistor in component holder Q.
  - Set up the circuit shown in Fig. 1.1.

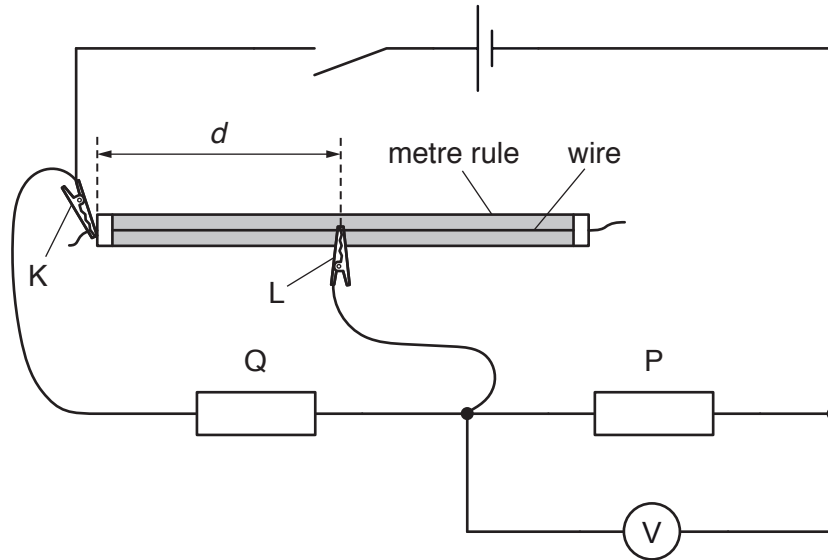

Fig. 1.1

- K and L are crocodile clips.
- The resistor in component holder Q has resistance  $R$ .
- Place L approximately half-way along the wire.
- The distance between K and L is  $d$ , as shown in Fig. 1.1.
- Record  $R$  and  $d$ .

$R = \dots\dots\dots$

$d = \dots\dots\dots$

- Close the switch.
- Record the voltmeter reading  $V$ .

$V = \dots\dots\dots$

- Open the switch.

[1]

- (b)
- Change the resistor in Q. Do **not** change the resistor in P.
  - Record the new value of  $R$ .

$R =$  .....

- Close the switch.
- Change the position of L on the wire so that the voltmeter reading is as close as possible to the value for  $V$  in (a).
- Record  $d$ .

$d =$  .....

- Open the switch.

[1]

- (c) • Write down your value of  $V$  from (a).

$V =$  .....

- Repeat (b) until you have six sets of readings of  $R$  and  $d$ . Include your readings from (a) and (b).

Record your results in a table. Include values of  $\frac{R}{d}$  in your table.

- (d) (i) Plot a graph of  $\frac{R}{d}$  on the  $y$ -axis against  $R$  on the  $x$ -axis. [10]
- (ii) Draw the straight line of best fit. [3]
- (iii) Determine the gradient and  $y$ -intercept of this line. [1]

gradient = .....

$y$ -intercept = .....

[2]



- (e) It is suggested that the quantities  $R$  and  $d$  are related by the equation

$$\frac{R}{d} = AR + B$$

where  $A$  and  $B$  are constants.

Using your answers in (d)(iii), determine values for  $A$  and  $B$ .  
Give appropriate units.

$A =$  .....

$B =$  .....

[2]

[Total: 20]

You may not need to use all of the materials provided.

2 In this experiment, you will investigate the motion of two pendulums.

(a) (i) You have been provided with two pendulums.

- Set up the apparatus using the pendulum that has a loop of string at the end, as shown in Fig. 2.1.

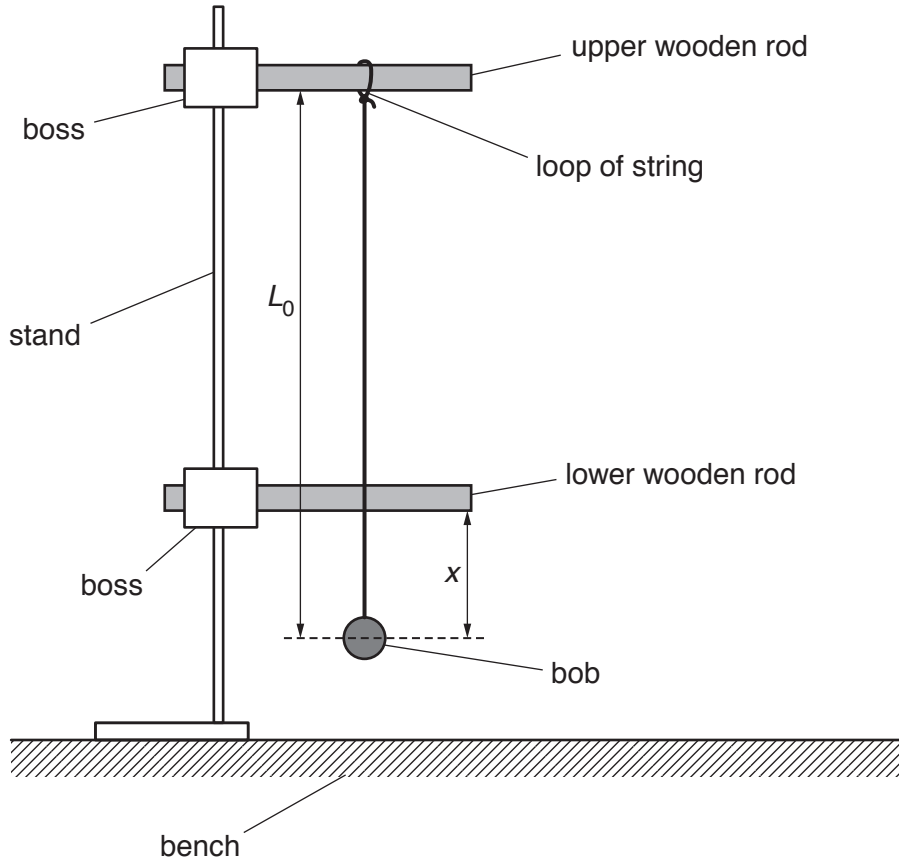

Fig. 2.1

- The distance between the bottom of the lower wooden rod and the centre of the bob is  $x$ .

The distance between the bottom of the upper wooden rod and the centre of the bob is  $L_0$ .

Adjust the position of the lower wooden rod until  $x$  is approximately 10 cm.

- Measure and record  $x$  and  $L_0$ .

$x =$  .....

$L_0 =$  .....

[1]

(ii) Estimate the percentage uncertainty in your value of  $x$ .

percentage uncertainty = ..... [1]

(b) (i) • Set up a second pendulum as shown in Fig. 2.2.

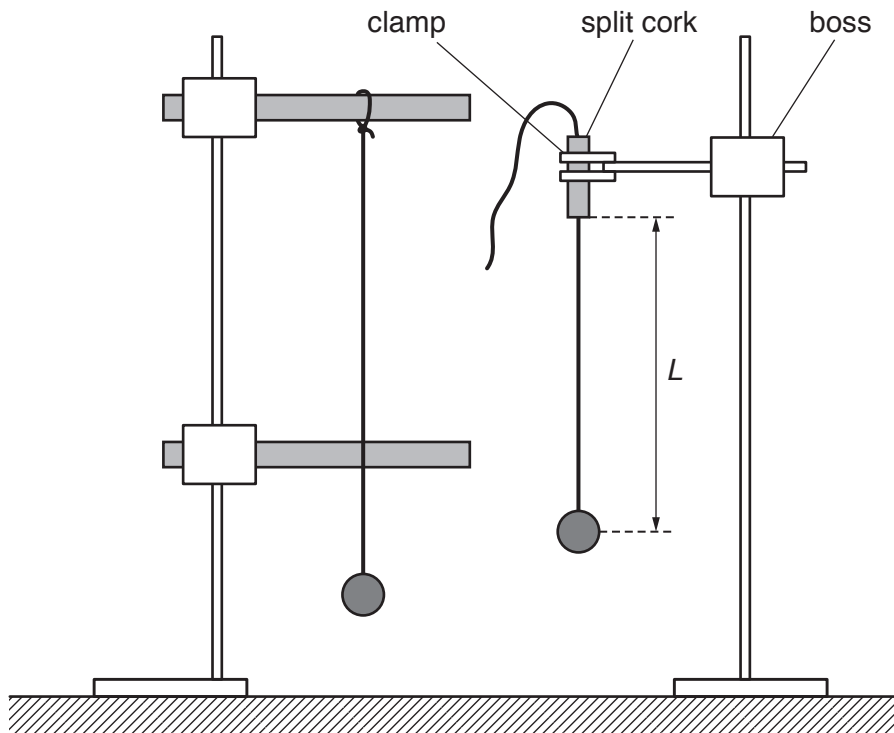

Fig. 2.2

- The distance between the bottom of the split cork and the centre of the bob is  $L$ .  
Adjust the string in the split cork until  $L$  is approximately 30 cm.
- Pull both bobs towards you through a short distance.
- Release the bobs at the same time. The oscillations of the bobs will be out of phase.
- Adjust  $L$  so that the oscillations of the bobs remain in phase for several cycles after release.
- Measure and record  $L$ .

$L =$  ..... [1]



(ii) Calculate  $\sqrt{L}$ .

$\sqrt{L} = \dots\dots\dots$  [1]

(iii) Justify the number of significant figures that you have given for your value of  $\sqrt{L}$ .

.....  
.....  
..... [1]

- (c) • Adjust the position of the lower wooden rod until  $x$  is approximately 35 cm.  
• Measure and record  $x$ .

$x = \dots\dots\dots$

- Repeat (b)(i) and (b)(ii).

$L = \dots\dots\dots$

$\sqrt{L} = \dots\dots\dots$   
[3]

(d) It is suggested that the relationship between  $L$  and  $x$  is

$$2\sqrt{L} = k + \sqrt{x}$$

where  $k$  is a constant.

(i) Using your data, calculate two values of  $k$ .

first value of  $k$  = .....

second value of  $k$  = .....

[1]

(ii) Explain whether your results support the suggested relationship.

.....  
.....  
.....  
..... [1]

- (e) (i) • Remove the lower wooden rod.
- Take measurements to determine the period  $T$  of the oscillations of the pendulum of length  $L_0$ .

$T = \dots\dots\dots$  s [1]

- (ii) Theory suggests that

$$T = \frac{2\pi k}{\sqrt{g}}$$

where  $g$  is the acceleration of free fall.

Use your second value of  $k$  to determine a value for  $g$ . Give appropriate units.

$g = \dots\dots\dots$  [1]

(f) (i) Describe four sources of uncertainty or limitations of the procedure for this experiment.

- 1. ....  
.....
- 2. ....  
.....
- 3. ....  
.....
- 4. ....  
.....

[4]

(ii) Describe four improvements that could be made to this experiment. You may suggest the use of other apparatus or different procedures.

- 1. ....  
.....
- 2. ....  
.....
- 3. ....  
.....
- 4. ....  
.....

[4]

[Total: 20]

---

Permission to reproduce items where third-party owned material protected by copyright is included has been sought and cleared where possible. Every reasonable effort has been made by the publisher (UCLES) to trace copyright holders, but if any items requiring clearance have unwittingly been included, the publisher will be pleased to make amends at the earliest possible opportunity.

To avoid the issue of disclosure of answer-related information to candidates, all copyright acknowledgements are reproduced online in the Cambridge Assessment International Education Copyright Acknowledgements Booklet. This is produced for each series of examinations and is freely available to download at [www.cambridgeinternational.org](http://www.cambridgeinternational.org) after the live examination series.

Cambridge Assessment International Education is part of the Cambridge Assessment Group. Cambridge Assessment is the brand name of the University of Cambridge Local Examinations Syndicate (UCLES), which itself is a department of the University of Cambridge.