

Cambridge  
International  
AS & A Level

**Cambridge International Examinations**  
Cambridge International Advanced Subsidiary and Advanced Level

CANDIDATE  
NAME

CENTRE  
NUMBER

|  |  |  |  |  |
|--|--|--|--|--|
|  |  |  |  |  |
|--|--|--|--|--|

CANDIDATE  
NUMBER

|  |  |  |  |
|--|--|--|--|
|  |  |  |  |
|--|--|--|--|

**BIOLOGY**

**9700/31**

Paper 3 Advanced Practical Skills 1

**October/November 2017**

**2 hours**

Candidates answer on the Question Paper.

Additional Materials: As listed in the Confidential Instructions.

**READ THESE INSTRUCTIONS FIRST**

Write your Centre number, candidate number and name on all the work you hand in.

Write in dark blue or black pen.

You may use an HB pencil for any diagrams or graphs.

Do not use staples, paper clips, glue or correction fluid.

DO **NOT** WRITE IN ANY BARCODES.

Answer **all** questions.

Electronic calculators may be used.

You may lose marks if you do not show your working or if you do not use appropriate units.

At the end of the examination, fasten all your work securely together.

The number of marks is given in brackets [ ] at the end of each question or part question.

**For Examiner's Use**

|              |  |
|--------------|--|
| <b>1</b>     |  |
| <b>2</b>     |  |
| <b>Total</b> |  |

This document consists of **16** printed pages.

Before you proceed, read carefully through the **whole** of Question 1 and Question 2.

Plan the use of the **two hours** to make sure that you finish all the work that you would like to do.

If you have enough time, think about how you can improve the accuracy of your results, for example by obtaining and recording one or more additional measurements.

You will **gain marks** for recording your results according to the instructions.

**1** You are required to estimate the water potential of potato tissue.

When a piece of potato is put into a sucrose solution, as shown in Fig. 1.1, water will move by osmosis into and out of the potato cells. The net direction of movement of water depends on the difference in water potential between the potato cells and the sucrose solution.

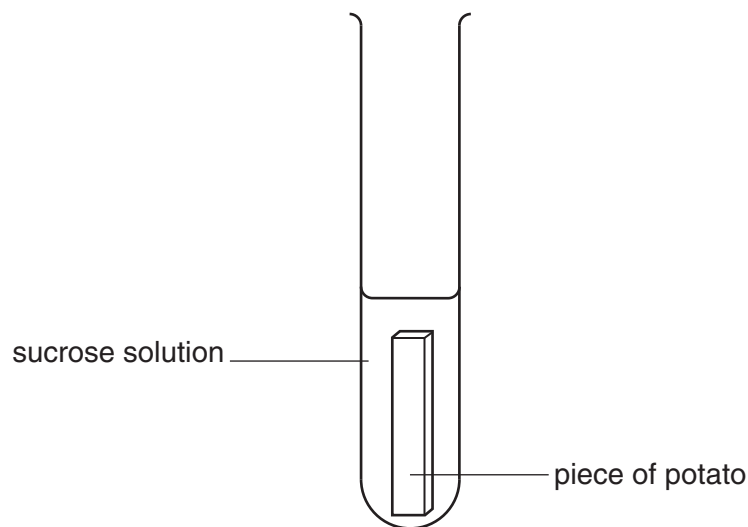

**Fig. 1.1**

**(a) (i)** Complete the sentences by using **two** of the following words.

**gain**

**less**

**lose**

**more**

If the potato cells ..... water then the sucrose solution will become more dilute.

This will change the sucrose solution so that it becomes ..... dense.

[1]

A piece of potato is left in a sucrose solution for 15 minutes, to allow time for osmosis to take place.

The concentration of the sucrose solution after 15 minutes may be different from the original concentration.

After 15 minutes a blue dye is added to the sucrose solution to make a blue solution. The blue dye does not affect the concentration of the sucrose solution.

A small volume of this blue solution is then released into a known concentration of sucrose solution as shown in Fig. 1.2.

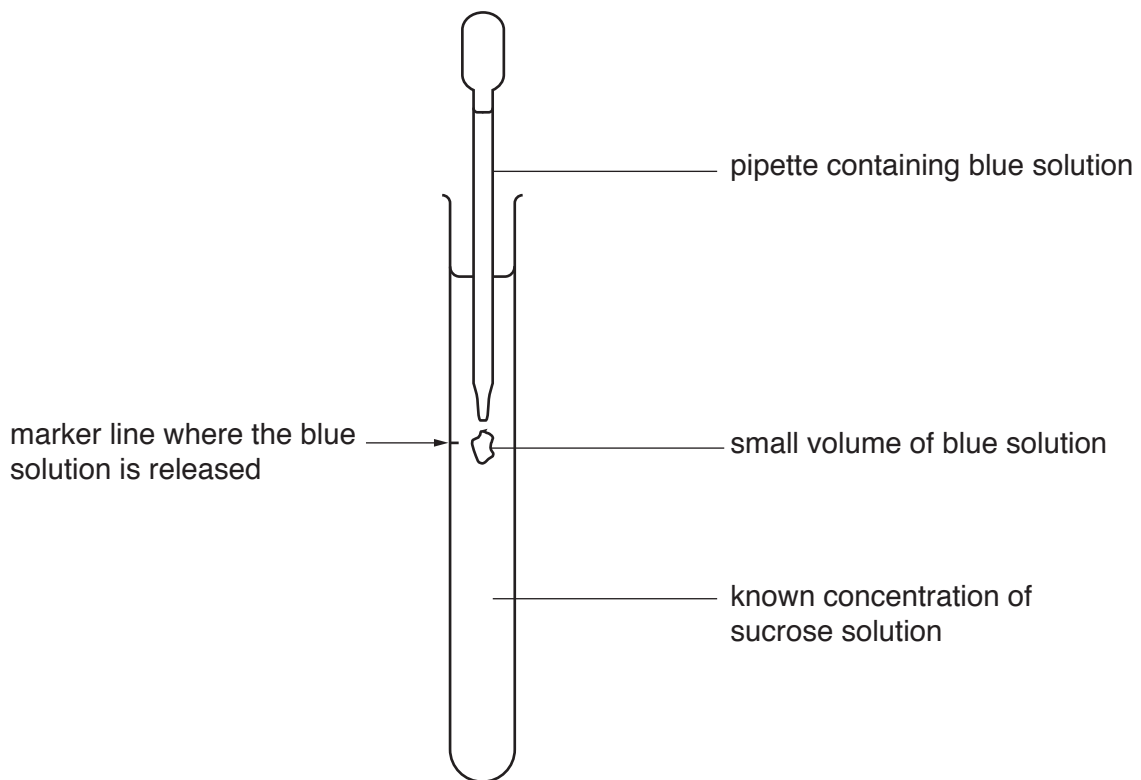

**Fig. 1.2**

The pipette is removed immediately after the blue solution is released.

The blue solution may move up, move down or remain at the same level depending on the difference in the concentration between the blue solution and the known concentration of sucrose solution.

- (ii) Think about how the blue solution will move in the known concentration of sucrose in the test-tubes shown in Fig. 1.3.

blue solution is  
**less** concentrated  
than the known  
sucrose solution

blue solution is the  
**same** concentration  
as the known  
sucrose solution

blue solution is  
**more** concentrated  
than the known  
sucrose solution

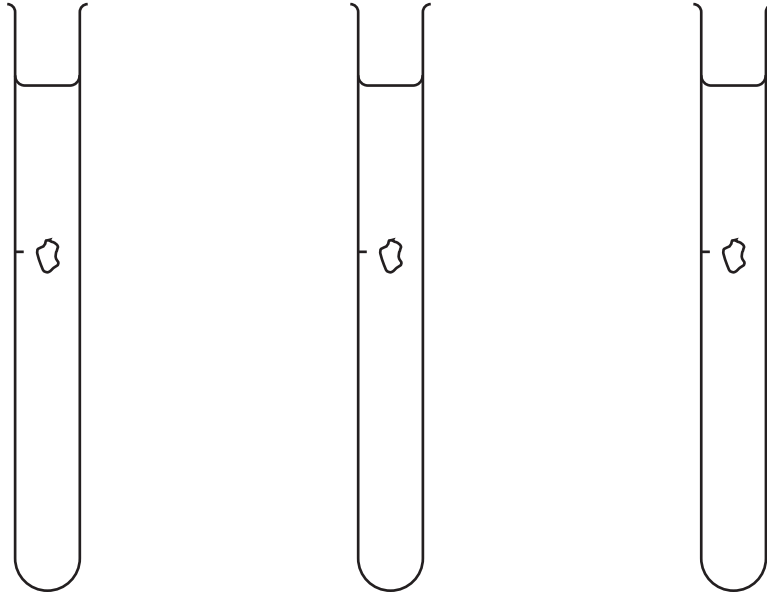

**Fig. 1.3**

Complete Fig. 1.3 by drawing an arrow on each test-tube, using the key, to show how you expect the blue solution to move.

key:

- ↑ blue solution moves up
- ↓ blue solution moves down
- blue solution remains at the same level

[1]

- (b) You are required to investigate osmosis in potato tissue so that you can estimate the water potential of the potato cells.

You are provided with:

| labelled | contents                                      | hazard | volume/cm <sup>3</sup> |
|----------|---|--------|------------------------|
| <b>S</b> | 1.00 mol dm <sup>-3</sup><br>sucrose solution | none   | 200                    |
| <b>W</b> | distilled water                               | none   | 200                    |

| labelled | details   |
|----------|---|
| <b>P</b> | 7 pieces of potato, cross sectional area 1.5 cm × 1.0 cm of variable length |

You are required to make simple dilutions of the 1.00 mol dm<sup>-3</sup> sucrose solution, **S**, which reduces the concentration between each dilution.

You will need to prepare 40 cm<sup>3</sup> of each concentration.

Decide which concentrations of sucrose solution to prepare using simple dilutions of **S**.

- (i) Complete Table 1.1 to show how you will prepare the other concentrations.

**Table 1.1**

| final concentration of<br>sucrose solution<br>/mol dm <sup>-3</sup> | volume of <b>S</b><br>/cm <sup>3</sup> | volume of distilled water,<br><b>W</b> /cm <sup>3</sup> |
|---|--|---|
| 1.00  | 40                                     | 0   |
|   |  |   |
|   |  |   |
|   |  |   |
|   |  |   |
|   |  |   |
|   |  |   |
|   |  |   |
|   |  |   |

[3]

Read step 1 to step 11 before proceeding.

Proceed as follows:

1. Prepare all the concentrations of sucrose solution as shown in Table 1.1 in the beakers provided.
2. Measure 4.5 cm from the bottom of each **large** test-tube and put a mark, as shown in Fig. 1.4.

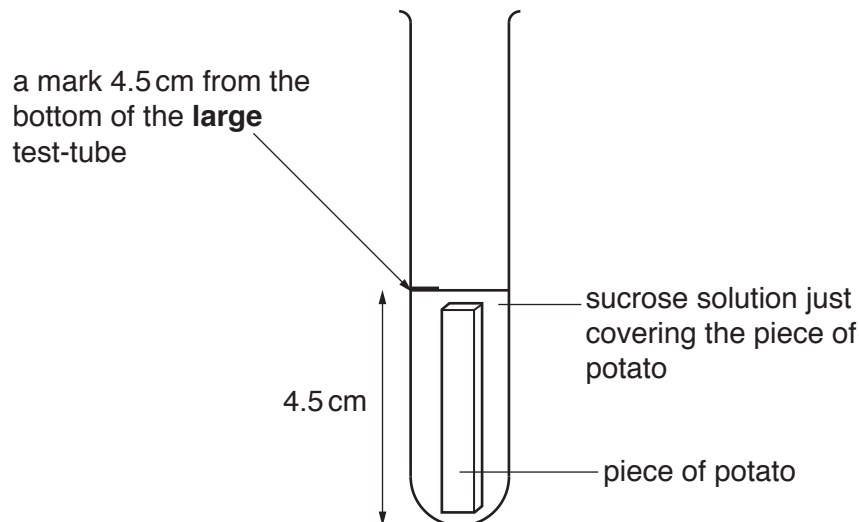

**Fig. 1.4**

- (ii) Decide on the length of each piece of potato you will use, so that the volume of sucrose solution just covers the piece of potato, as shown in Fig. 1.4.

State the length of the pieces of potato you will use.

length = ..... [1]

3. Cut enough pieces of potato to put into the sucrose concentrations that you prepared in step 1.
4. Put the pieces of potato on a paper towel to remove any excess fluid.
5. Put one piece of potato into each of the large test-tubes from step 2.
6. Put  $1.00 \text{ mol dm}^{-3}$  sucrose solution, **S**, into a large test-tube up to the mark made in step 2.
7. Repeat step 6 with each of the other concentrations of sucrose solution.
8. Start timing and leave for 15 minutes.

*While you are waiting for 15 minutes continue with step 9 to step 11 and continue with the other questions.*

9. Measure 6 cm from the **top** of each of the **small** test-tubes and put a mark, as shown in Fig. 1.5.

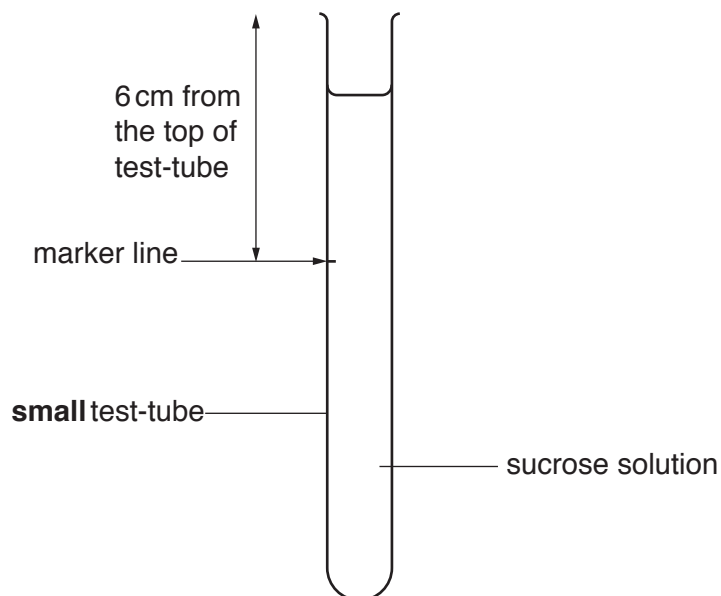

**Fig. 1.5**

10. Put  $15\text{ cm}^3$  of  $1.00\text{ mol dm}^{-3}$  sucrose solution, **S**, into one of the **small** test-tubes from step 9.
11. Repeat step 10 with each of the other sucrose solutions that you prepared in step 1.

You are provided with:

| labelled | contents                | hazard | volume / $\text{cm}^3$ |
|----------|-------------------------|--------|------------------------|
| <b>M</b> | methylene blue solution | none   | 15                     |

12. After leaving the pieces of potato for 15 minutes, put a drop of **M** into the **large** test-tube containing  $1.00\text{ mol dm}^{-3}$  sucrose solution, **S**, and a piece of potato.
13. Gently shake the **large** test-tube to mix **M** with the sucrose solution.
14. Repeat step 12 and step 13 with each of the other concentrations of sucrose solution.

*Read step 15 to step 19 before proceeding.*

15. Use a pipette to remove a sample of the blue solution from the **large** test-tube containing  $1.00 \text{ mol dm}^{-3}$  sucrose solution, **S**.

*You will now use the **small** test-tubes as in Fig. 1.5.*

16. Put the end of the pipette into the **small** test-tube containing  $1.00 \text{ mol dm}^{-3}$  concentration of sucrose solution, **S**. This should be level with the marker line on the test-tube as shown in Fig. 1.2 on page 3.

17. Release a small volume of the blue solution, then immediately remove the pipette from the test-tube.

*It is possible to repeat step 17 without having to replace this sucrose solution.*

18. Immediately observe the direction **and** the speed of movement of the blue solution.

*You are **not** required to measure the speed.*

Record these observations in **(b)(iii)**.

19. Repeat step 15 to step 18 using the other concentrations of sucrose solution. Make sure that the small volume of the blue solution from the **large** test-tube is put into the **small** test-tube labelled with the same concentration.

**(iii)** Record your observations of direction and speed of movement in an appropriate table.

[6]



(iv) Using your results in (b)(iii) estimate the concentration of sucrose solution with a water potential equal to the water potential of the potato tissue.

.....  
.....[1]

(v) Identify **one** significant source of error in this investigation.

.....  
.....  
.....[1]

(vi) Describe how you would use this procedure to produce a more accurate estimate of the concentration of sucrose solution with a water potential equal to the water potential of the potato tissue.

.....  
.....  
.....  
.....  
.....  
.....  
.....  
.....[3]

(vii) Describe the movement of water when the concentration of the sucrose solution surrounding the piece of potato has a water potential equal to the water potential in the potato tissue.

.....  
.....[1]

- (viii) Using the same procedure a student observed that the blue solution stayed in the same position (did not move up or down) in a concentration of sucrose solution of  $0.3 \text{ mol dm}^{-3}$ .

Fig. 1.6 shows the relationship between the concentration of sucrose solution and the water potential of the sucrose solution.

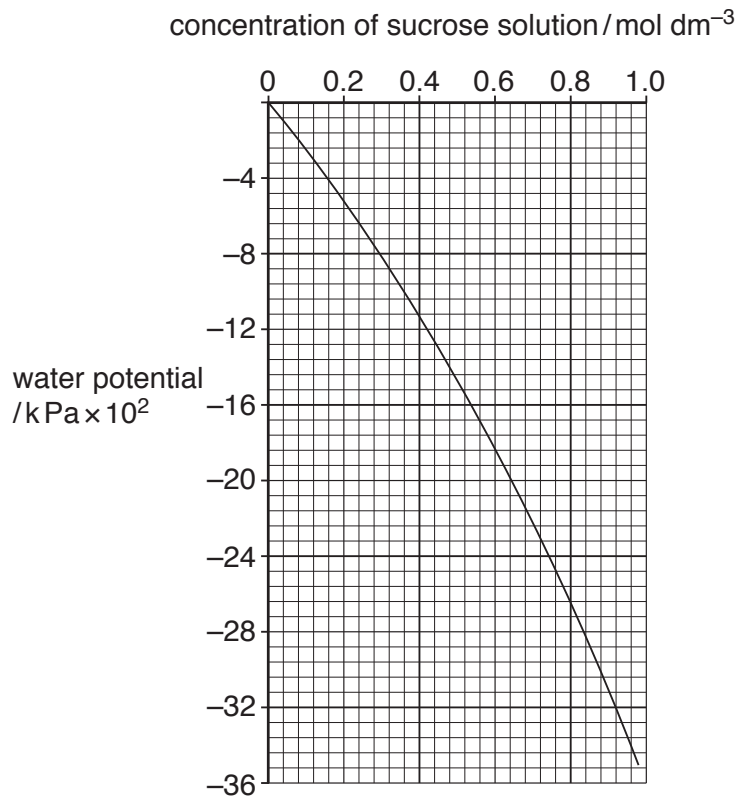

**Fig. 1.6**

Use the graph in Fig. 1.6 to estimate the water potential of a  $0.3 \text{ mol dm}^{-3}$  sucrose solution. Show on the graph how you estimated the water potential.

water potential ..... [2]

[Total: 20]

**Question 2 starts on page 12**

## 2 Some plants store starch as grains.

Some starch grains have rings on the surface and the grains from different plant types differ in size and shape.

You are required to:

- observe and draw starch grains from two different types of plant
- compare the starch grains from these two different types of plant.

You are provided with starch grains, in water, from two different types of plant, labelled **F** and **G**.

1. Put one **clean and dry** microscope slide on a piece of black card with a paper towel underneath as shown in Fig. 2.1.

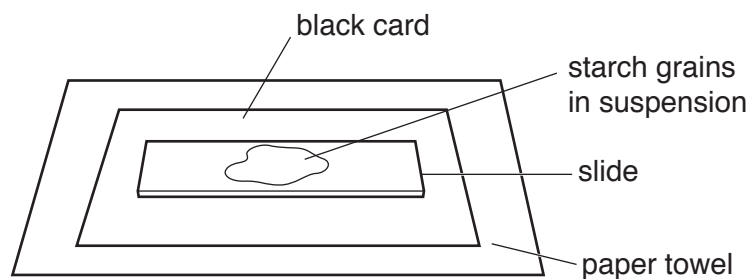

**Fig. 2.1**

2. Using a pipette put a few drops of **F** containing starch grains onto the slide.
3. Cover the starch grains with a coverslip and use a paper towel to remove any excess liquid that is outside the coverslip.
4. View the slide to observe the starch grains using the microscope. Select an area of starch grains on the slide.

*You may need to reduce the amount of light entering the microscope to observe the grains clearly.*

*You must adjust the fine focus to observe the starch grains.*

5. Select **three** starch grains which show the different sizes and features of the grains.
6. Make a large drawing in **(a)(i)** of the three starch grains that you have selected.
7. Remove the slide from the microscope and place on a paper towel.
8. Repeat step 1 to step 7 with **G**.

Use a sharp pencil for drawing.

- (a) (i) Make a large drawing of the three starch grains from **F** and the three starch grains from **G**.

Use **one** ruled label line and label **X** to identify the surface markings of **one** starch grain.

*starch grains from F*

*starch grains from G*

[5]

- (ii) Annotate your drawings in (a)(i) to describe **three** observable differences between the starch grains from **F** and **G** by:
- drawing label lines to each of the features on the starch grains that show these differences
  - describing next to each line how each feature is different.

[3]

- (b) A student investigated the effect of human salivary amylase on starch. 1 cm<sup>3</sup> of salivary amylase was mixed with 10 cm<sup>3</sup> of a known concentration of starch and kept at 25 °C. The concentration of reducing sugar was measured at intervals for 60 minutes.

All other variables were standardised.

The results are shown in Table 2.1.

**Table 2.1**

| <b>time<br/>/minutes</b> | <b>reducing sugar<br/>concentration/<math>\mu</math>M</b> |
|--------------------------|---|
| 0                        | 0.0   |
| 10                       | 4.2   |
| 20                       | 7.3   |
| 30                       | 9.6   |
| 50                       | 10.4  |
| 60                       | 10.5  |

Use a sharp pencil for drawing graphs.

- (i) Plot a graph of the data shown in Table 2.1.

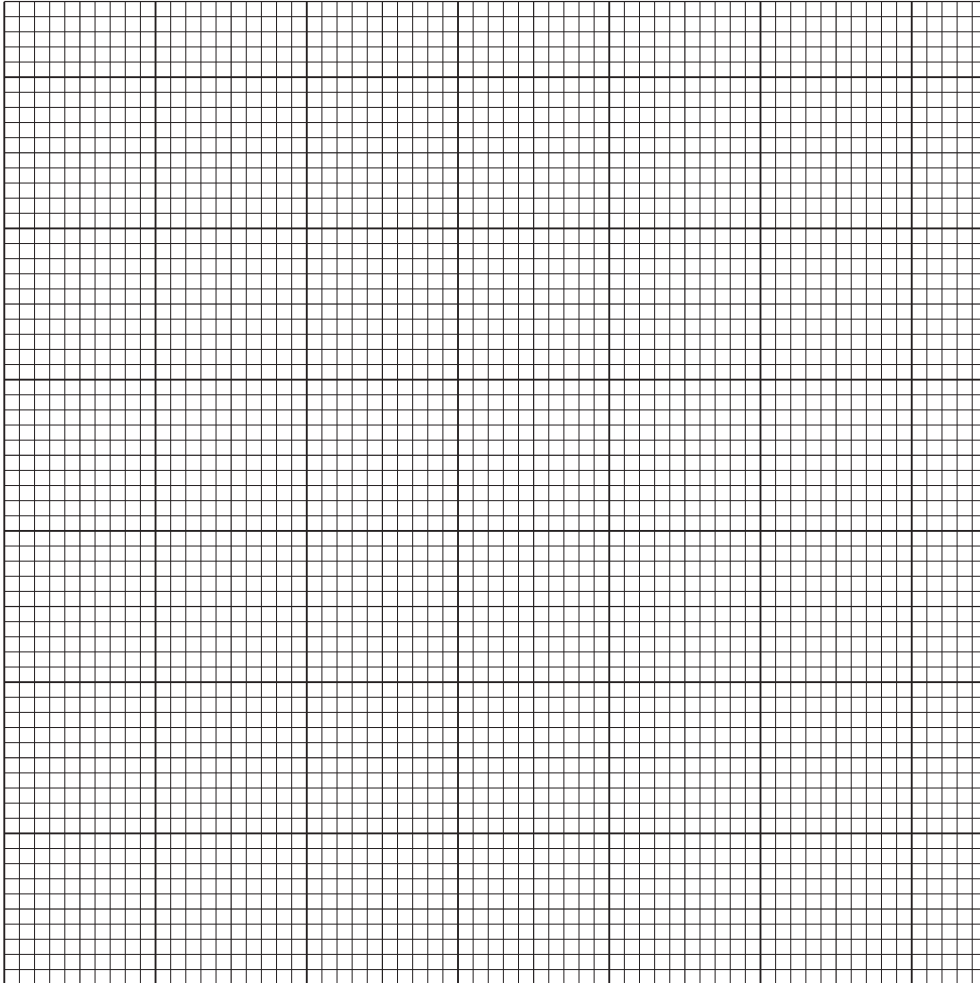

[4]

- (ii) Use your graph to calculate the **percentage** increase in concentration of reducing sugar between 15 minutes and 35 minutes.

You may lose marks if you do not show all your working.

% increase ..... [3]

Fig. 2.2 is a photomicrograph of a stained transverse section through a stem. You are not expected to be familiar with this specimen.

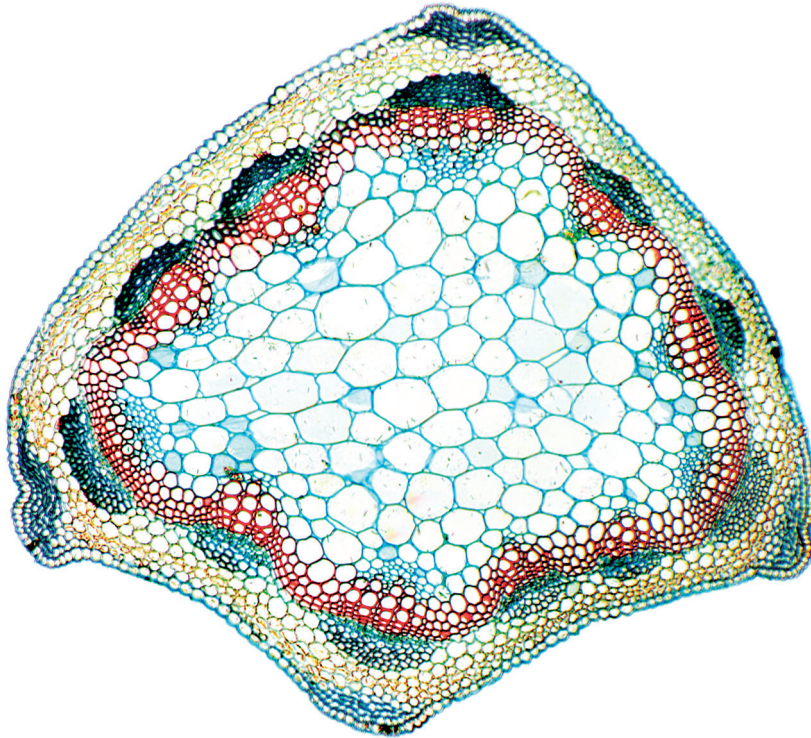

**Fig. 2.2**

Observe the different tissues in Fig. 2.2 and select an area that shows part of the epidermis and the vascular bundles.

*Use a sharp pencil for drawing.*

**(c)** Draw **one** large plan diagram from the selected area which shows:

- part of the epidermis
- only **three** vascular bundles
- any other observable tissues.

Use **one** ruled label line and label to identify the phloem.

[5]

[Total: 20]

**Note:**

For those candidates who started with Question 2, start Question 1 as soon as you have completed Question 2. Questions **1(a)(i)**, **1(a)(ii)**, **1(b)(i)** and **1(b)(viii)** do not need apparatus.

To avoid the issue of disclosure of answer-related information to candidates, all copyright acknowledgements are reproduced online in the Cambridge International Examinations Copyright Acknowledgements Booklet. This is produced for each series of examinations and is freely available to download at [www.cie.org.uk](http://www.cie.org.uk) after the live examination series.