

**Cambridge  
International  
AS & A Level**

**Cambridge International Examinations**  
Cambridge International Advanced Subsidiary and Advanced Level

CANDIDATE  
NAME

CENTRE  
NUMBER

--	--	--	--	--	--

CANDIDATE  
NUMBER

--	--	--	--



**BIOLOGY**

**9700/34**

Paper 3 Advanced Practical Skills 2

**October/November 2016**

**2 hours**

Candidates answer on the Question Paper.

Additional Materials: As listed in the Confidential Instructions.

**READ THESE INSTRUCTIONS FIRST**

Write your Centre number, candidate number and name on all the work you hand in.  
Write in dark blue or black pen.  
You may use an HB pencil for any diagrams or graphs.  
Do **not** use staples, paperclips, glue or correction fluid.  
**DO NOT WRITE IN ANY BARCODES.**

Answer **all** questions.

Electronic calculators may be used.  
You may lose marks if you do not show your working or if you do not use appropriate units.

At the end of the examination, fasten all your work securely together.  
The number of marks is given in brackets [ ] at the end of each question or part question.

For Examiner's Use	
1	
2	
<b>Total</b>	

This document consists of **12** printed pages and **4** blank pages.

Before you proceed, read carefully through the **whole** of Question 1 and Question 2.

Plan the use of the **two hours** to make sure that you finish all the work that you would like to do.

If you have enough time, think about how you can improve the accuracy of your results, for example by obtaining and recording one or more additional measurements.

You will **gain marks** for recording your results according to the instructions.

- 1 When plant cells are placed into different concentrations of sodium chloride solution, water moves between the cells and the solutions. This will affect how much a piece of plant tissue can bend.

Fig. 1.1, Fig. 1.2 and Fig. 1.3 show the method you will use to measure the angle of bend of a piece of plant tissue (potato).

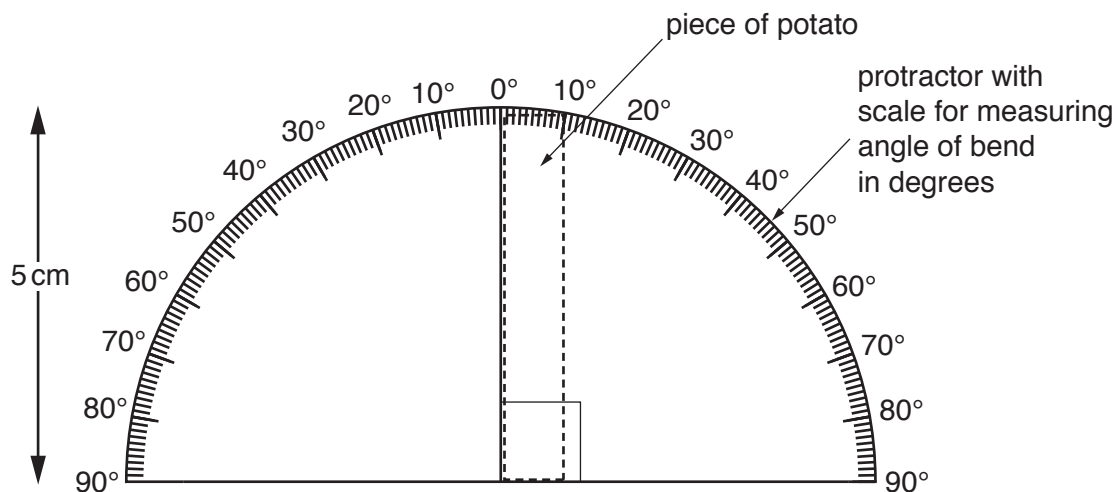

**Fig. 1.1**

*Note: you are provided with a sheet showing 4 protractors.*

*Do **not** cut these into separate protractors. Do **not** remove from the plastic covering.*

*You may use one or more of these to obtain your results.*

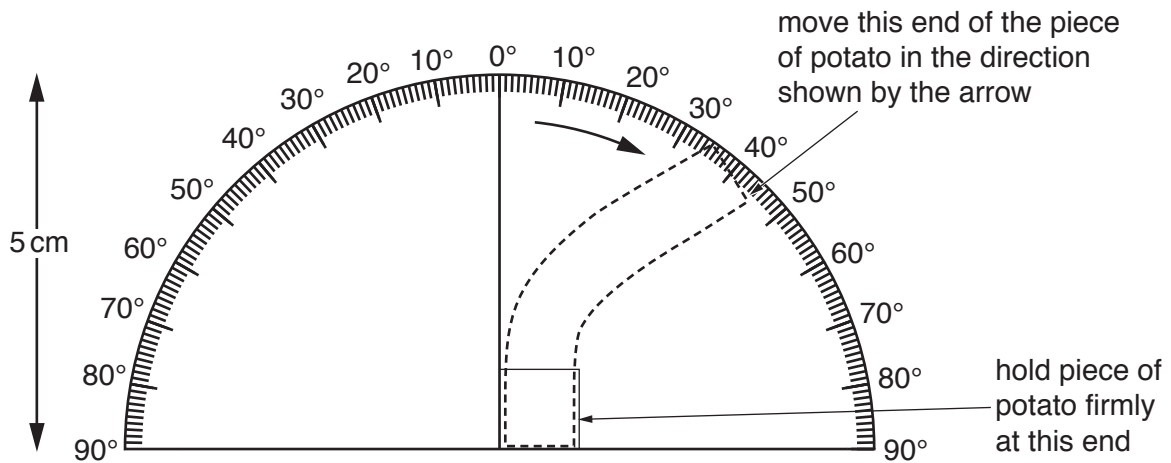

Fig. 1.2

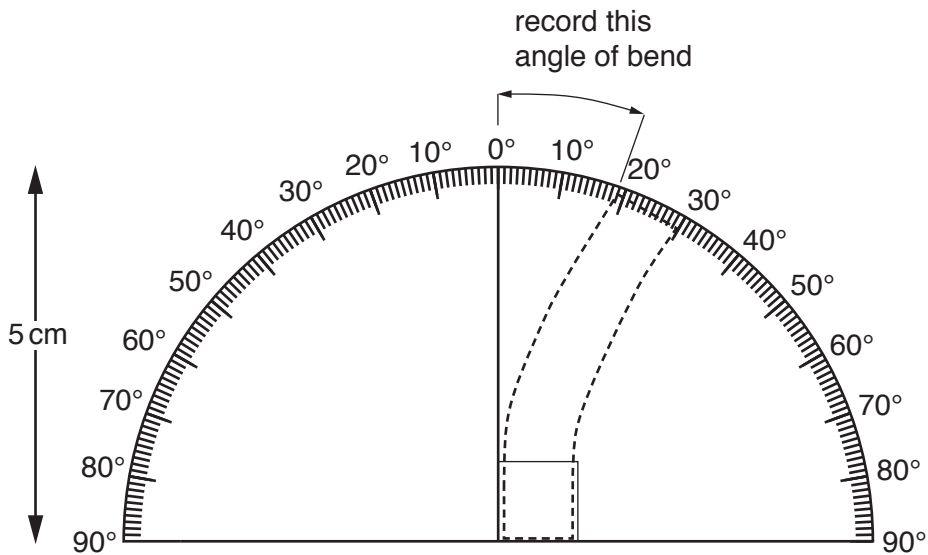

Fig. 1.3

#### Method of measuring the angle of bend

- Put the piece of potato in the starting position on one of the protractors provided, as shown in Fig. 1.1.
- Hold the bottom of the piece of potato **firmly** as shown in Fig. 1.2.
- Move the top of the piece of potato until there is some resistance.
- Release the top of the piece of potato.
- Measure the angle of bend, after releasing the top of the piece of potato, as shown in Fig. 1.3. The maximum angle of bend is 90°.

*Note: before measuring, remove excess liquid from the piece of potato and make sure the plastic covering on the page of protractors is dry.*

**BLANK PAGE**

You are provided with four different concentrations of sodium chloride solution labelled **S1**, **S2**, **S3** and **S4**. Each concentration of sodium chloride solution contains two pieces of potato.

**S1**, **S2** and **S3** each contain one of the concentrations of sodium chloride solution,  $1.00 \text{ mol dm}^{-3}$ ,  $0.50 \text{ mol dm}^{-3}$  and  $0.25 \text{ mol dm}^{-3}$  but not necessarily in that order.

**S4** has an unknown concentration of sodium chloride solution.

(a) (i) Complete the sentence by selecting the correct word from: **least** or **most** or **same**.

The piece of potato soaked in the lowest concentration of sodium chloride solution will have the ..... angle of bend when compared to the other concentrations of sodium chloride solution. [1]

You are required to:

- measure the angle of bend for each of the pieces of potato from **S1**, **S2** and **S3**
- use these results to identify the concentrations of the sodium chloride solutions, **S1**, **S2** and **S3**.

The size of the pieces of potato is a variable which needs to be standardised.

(ii) Decide how you will make sure that the pieces of potato are a standard size.

State the size you will use.

.....  
.....[1]

(iii) Describe how you will obtain accurate results to record the angle of bend.

.....  
.....[1]

Proceed as follows:

1. Cut the pieces of potato as stated in (a)(ii) and return to the appropriate solution.
2. Before measuring the angle of bend, remove excess liquid from the piece of potato using the paper towel.
3. Measure the angle of bend of the pieces of potato from **S1**, **S2** and **S3** using the **Method of measuring the angle of bend** as described on page 3.

*Note: before measuring, remove excess liquid from the piece of potato and make sure the plastic covering on the page of protractors is dry.*

4. Record your results in (a)(iv).

(iv) Prepare the space below and record your results.

[5]

(v) Using your results in (a)(iv) state the concentration of sodium chloride solution in **S1**, **S2** and **S3**.

**S1** ..... mol dm<sup>-3</sup>

**S2** ..... mol dm<sup>-3</sup>

**S3** ..... mol dm<sup>-3</sup>

[1]

5. Repeat step 3 using the pieces of potato from **S4** and record your result in (a)(vi).

(vi) Record the angle of bend for the pieces of potato from **S4**.

.....  
.....  
.....[1]

(vii) Estimate the concentration of the sodium chloride solution in **S4** using your results in (a)(iv), (a)(v) and (a)(vi).

.....[1]

You are expected to use a sharp pencil to draw graphs.

A student recorded angles of bend of  $0^\circ$  for pure water ( $0 \text{ mol dm}^{-3}$  sodium chloride solution) and  $2^\circ$  for  $0.15 \text{ mol dm}^{-3}$  sodium chloride solution.

- (viii) Plot a graph to show the relationship between the concentration of sodium chloride solution and the angle of bend using:
- the results recorded by the student
  - your results as recorded in **(a)(iv)**
  - the concentrations of sodium chloride solution stated in **(a)(v)**.

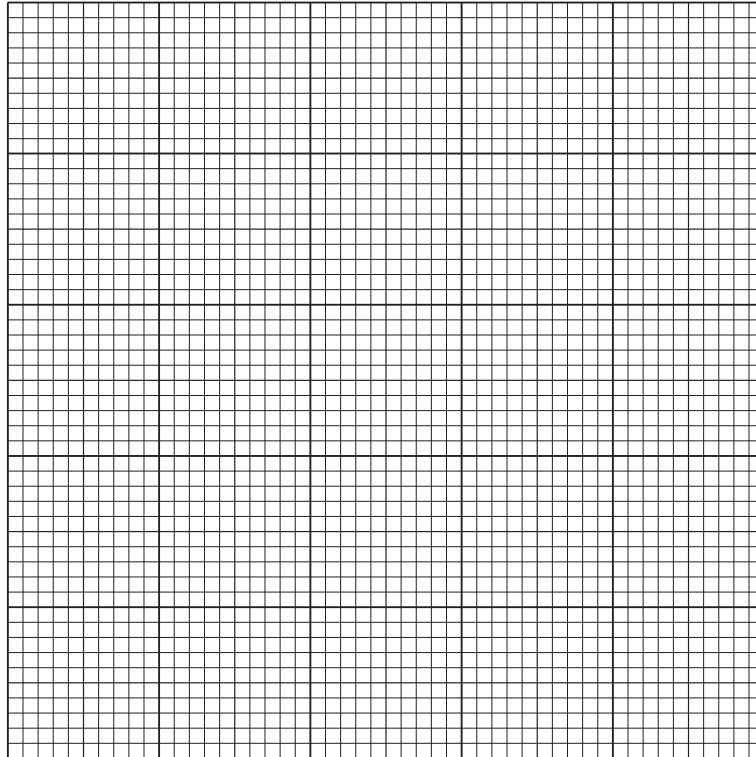

[3]

- (ix) A more accurate estimate for the concentration of sodium chloride solution in **S4** can be found by using this graph.

Use your graph to estimate the concentration of sodium chloride solution in **S4** using your answer to **(a)(vi)**.

Show on the graph how you estimated the concentration of sodium chloride solution.

concentration in **S4** .....[2]

(b) Suggest how you would improve this procedure to have more confidence in your estimate of **S4**.

.....  
.....  
.....  
.....  
.....[3]

(c) A student puts a piece of the potato from **S1** into water.  
Explain, in terms of water potential, the effect this would have on the potato cells.

.....  
.....  
.....  
.....  
.....[2]

[Total: 21]



**Question 2 starts on page 10**

2 L1 is a slide of a stained transverse section through a plant leaf.

You are not expected to be familiar with this specimen.

(a) Select a field of view so that you can observe the part of the leaf shown by the shaded area in Fig. 2.1.

*You are required to use a sharp pencil for drawings.*

(i) Draw a large plan diagram of the part of the leaf observed in the field of view.

Use **one** ruled label line and label to identify one layer of epidermis.

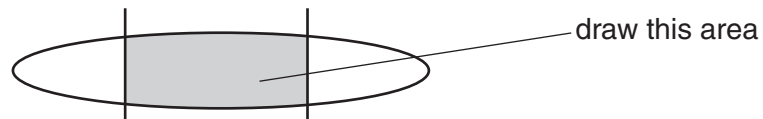

**Fig. 2.1**

*You are expected to draw the correct shape and proportions of the different tissues.*

[6]

- (ii) Observe the cells in the ring around the vascular bundle on **L1**.  
These cells are not identical.

Select one group of **four** adjacent (touching) cells which show some of the differences between these cells.

Each cell of the group must touch at least one of the other cells.

Make a large drawing of this group of **four** cells.

Use **one** ruled label line and label to identify the cell wall of **one** cell.

[6]

(b) Fig. 2.2 is a photomicrograph of a stained transverse section through a leaf of a different type of plant.

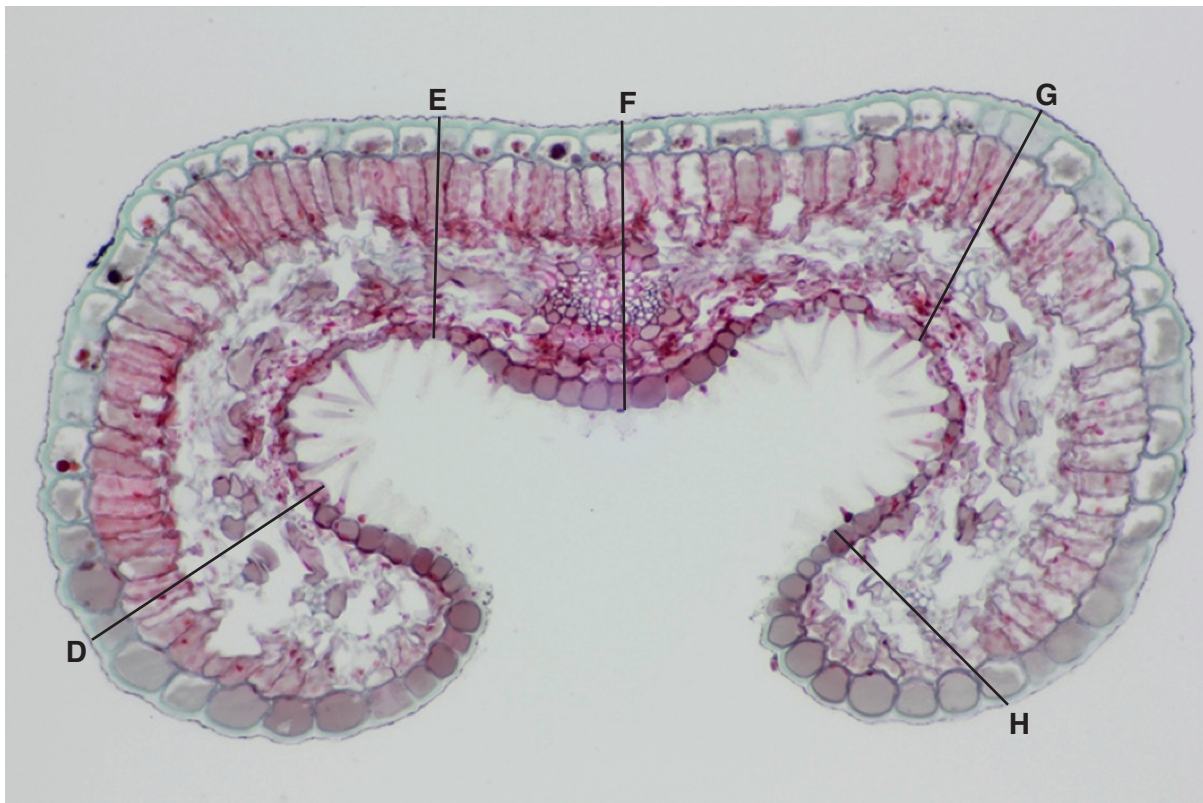

magnification  $\times 75$

**Fig. 2.2**

(i) Use the magnification and the lines in Fig. 2.2 to find the actual thickness of the leaf, in  $\mu\text{m}$ , at the positions labelled **D**, **E**, **F**, **G** and **H**.

*You may lose marks if you do not show your working.*

**D** .....  $\mu\text{m}$ , **E** .....  $\mu\text{m}$ , **F** .....  $\mu\text{m}$ , **G** .....  $\mu\text{m}$ , **H** .....  $\mu\text{m}$  [2]

- (ii) Using the actual thicknesses calculated in (b)(i), calculate the **mean** actual thickness of the leaf.

*You may lose marks if you do not show your working or if you do not use appropriate units.*

mean actual thickness .....[2]

- (c) The leaf on slide **L1** and the leaf in Fig 2.2 are adapted to living in dry conditions.

Prepare the space below so that it is suitable for you to record observable differences in xerophytic adaptations between these two specimens.

Record your observations in the space you have prepared.

[3]

[Total: 19]

**BLANK PAGE**

**BLANK PAGE**

**BLANK PAGE**

---

Permission to reproduce items where third-party owned material protected by copyright is included has been sought and cleared where possible. Every reasonable effort has been made by the publisher (UCLES) to trace copyright holders, but if any items requiring clearance have unwittingly been included, the publisher will be pleased to make amends at the earliest possible opportunity.

To avoid the issue of disclosure of answer-related information to candidates, all copyright acknowledgements are reproduced online in the Cambridge International Examinations Copyright Acknowledgements Booklet. This is produced for each series of examinations and is freely available to download at [www.cie.org.uk](http://www.cie.org.uk) after the live examination series.

Cambridge International Examinations is part of the Cambridge Assessment Group. Cambridge Assessment is the brand name of University of Cambridge Local Examinations Syndicate (UCLES), which is itself a department of the University of Cambridge.