



Cambridge O Level

BIOLOGY

5090/12

Paper 1 Multiple Choice

May/June 2022

1 hour

You must answer on the multiple choice answer sheet.

You will need: Multiple choice answer sheet
Soft clean eraser
Soft pencil (type B or HB is recommended)

INSTRUCTIONS

- There are **forty** questions on this paper. Answer **all** questions.
- For each question there are four possible answers **A, B, C** and **D**. Choose the **one** you consider correct and record your choice in soft pencil on the multiple choice answer sheet.
- Follow the instructions on the multiple choice answer sheet.
- Write in soft pencil.
- Write your name, centre number and candidate number on the multiple choice answer sheet in the spaces provided unless this has been done for you.
- Do **not** use correction fluid.
- Do **not** write on any bar codes.
- You may use a calculator.

INFORMATION

- The total mark for this paper is 40.
- Each correct answer will score one mark.
- Any rough working should be done on this question paper.

This document has **20** pages.



- 1 The diagram shows a plant cell. The cell is stained with iodine solution.

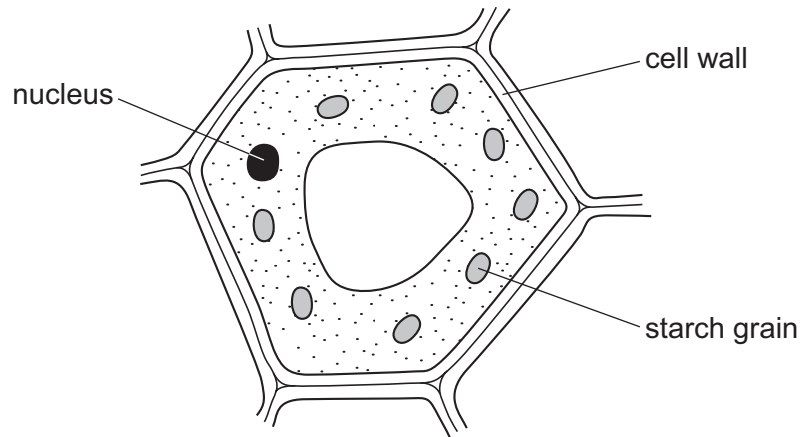

After staining with iodine solution, what are the colours of the cell wall and the starch grain?

	cell wall	starch grain
A	blue-black	blue-black
B	blue-black	orange-brown
C	orange-brown	blue-black
D	orange-brown	orange-brown

- 2 Xylem vessels are cells that have become adapted for conduction and support.

Which two adaptations assist them in these functions?

- A** presence of a nucleus and cytoplasm
 - B** lack of cytoplasm and woody cell walls
 - C** lack of a nucleus and presence of cytoplasm
 - D** presence of cytoplasm and woody cell walls
- 3 What is diffusion?
- A** movement of particles by the air
 - B** movement of molecules down a concentration gradient
 - C** movement of molecules in a heated liquid
 - D** movement of particles up a concentration gradient

- 4 The rate of nitrate ion absorption by a root hair cell was measured at different soil nitrate concentrations.

At X, the concentration of nitrate in the soil is the same as in the cell.

Which graph shows how the rate of absorption varies with nitrate concentration in the soil?

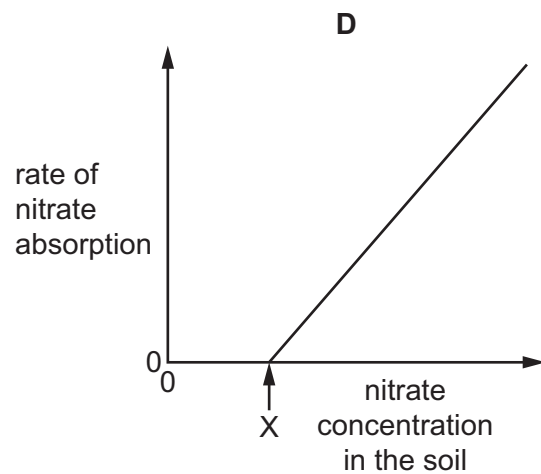
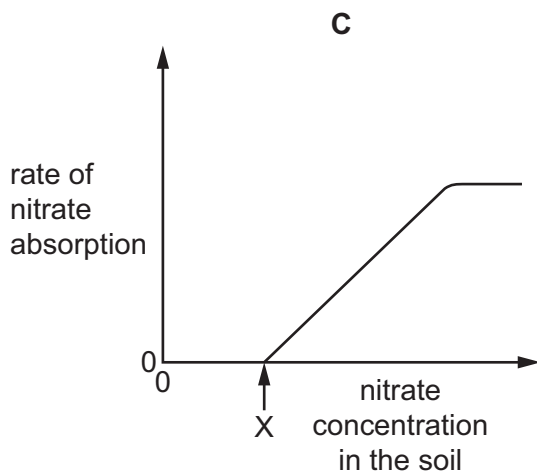
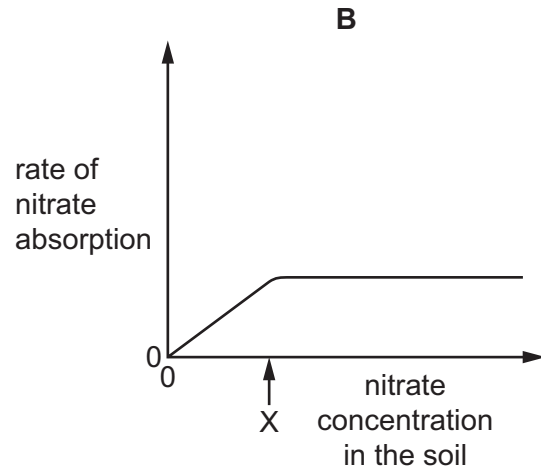
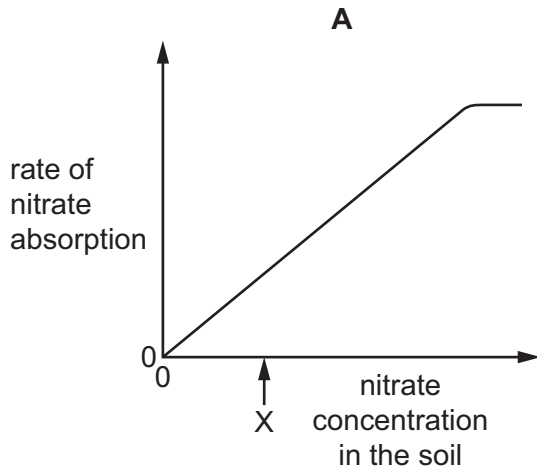

5 Amylase is an enzyme that breaks down starch to maltose.

Students set up an experiment to investigate the effect of different temperatures on the action of amylase on starch solution.

They measured the amount of starch remaining after 30 minutes at different temperatures.

Which graph would you expect the students to draw from their results?

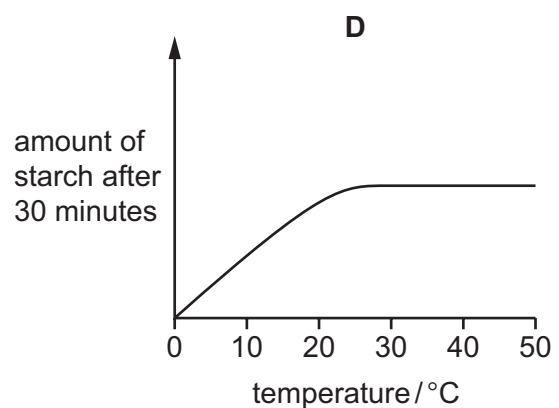
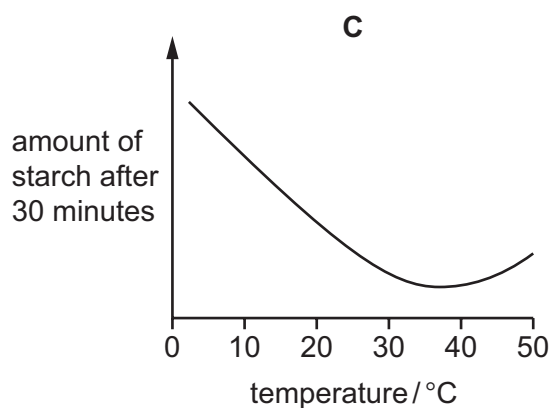
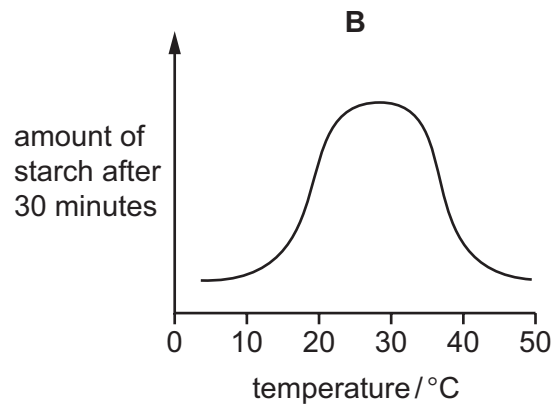
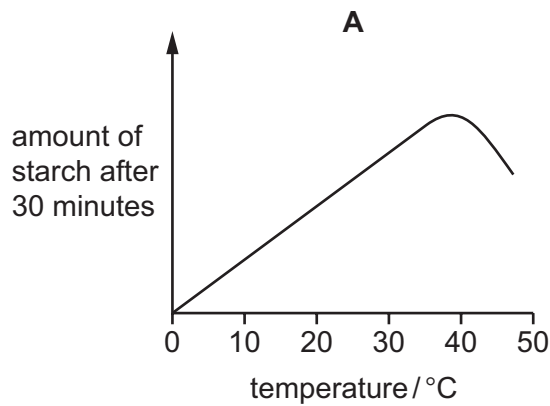

6 Which statement identifies the optimum (best) temperature for enzyme activity?

- A** It is the highest temperature at which any enzyme activity happens.
- B** It is the highest temperature that does not destroy an enzyme.
- C** It is the lowest temperature that denatures an enzyme.
- D** It is the temperature that produces the highest rate of enzyme activity.

- 7 A plant has leaves with both green and white areas. One of its leaves is partly covered with aluminium foil which blocks light.

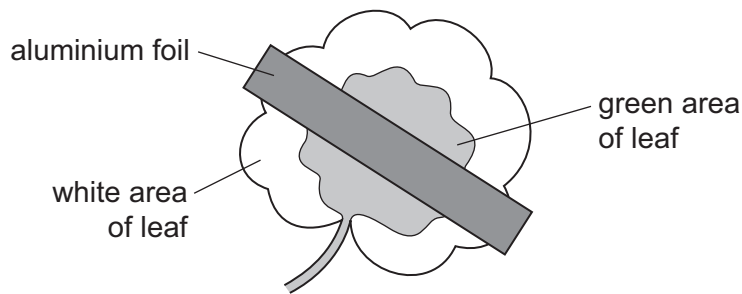

The plant is then placed under a lamp for 24 hours. After this time, discs are cut from the areas of the leaf shown, and tested with iodine solution.

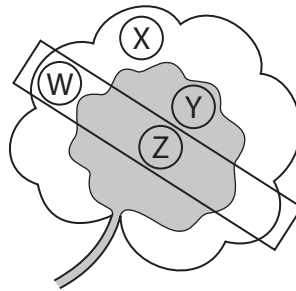

Which leaf discs will give a blue-black colour when tested with iodine solution?

- A** W and X **B** X only **C** Y and Z **D** Y only
- 8 Which row shows the effect of nitrate ions on plant growth and the reason for this effect?

	effect of nitrate ions on plant growth	reason for effect
A	no effect	fewer proteins made
B	increases	less chlorophyll made
C	decreases	more chlorophyll made
D	increases	more proteins made

- 9 The experiment shown was set up and left for 30 minutes.

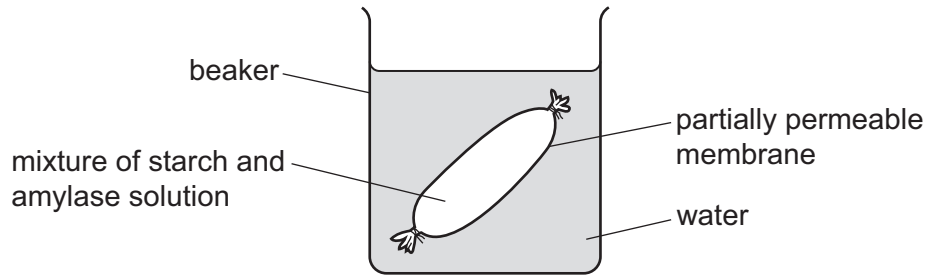

The membrane is permeable to sugar and water but not permeable to starch or protein. After 30 minutes, samples of the water in the beaker were tested with Benedict's reagent, biuret reagent and iodine solution.

Which colours were obtained with these tests?

	Benedict's test	biuret test	iodine test
A	blue	violet	blue-black
B	red	blue	brown
C	red	blue	blue-black
D	red	violet	brown

- 10 Sometimes gall bladders become infected and have to be surgically removed.

How will this affect the functioning of the body?

- A** reduce the digestion of carbohydrates
 - B** reduce the liver's ability to convert glucose to glycogen
 - C** reduce the amount of glycerol absorbed from the alimentary canal
 - D** reduce the volume of stored urine
- 11 What is an example of assimilation?
- A** absorption of glycerol into lacteals
 - B** breakdown of glycogen to glucose in the liver
 - C** building of proteins from amino acids
 - D** release of a hormone from a gland

12 A student set up an experiment to investigate the rate of transpiration in a plant.

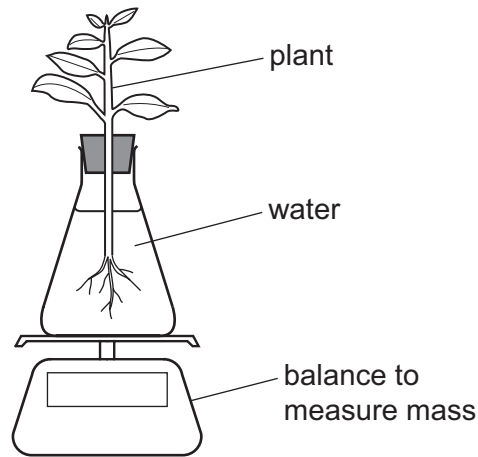

The student set up two identical sets of apparatus.

One was placed in a room at 20 °C with bright light and one in a room at 20 °C in the dark.

Which graph shows the student's results?

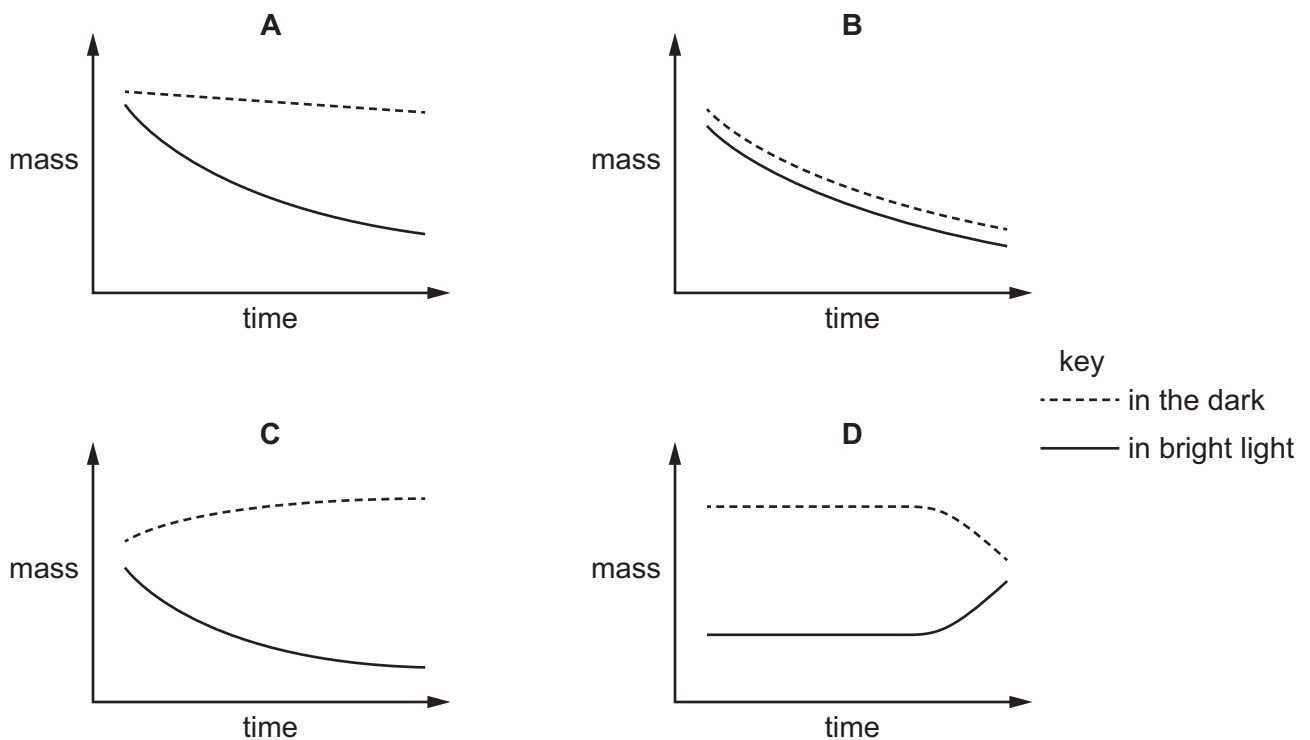

13 What is the main cause of water moving up to the leaves in xylem vessels?

- A active transport
- B evaporation from the epidermis of the leaf
- C evaporation from the walls of the mesophyll cells
- D use of water in photosynthesis

14 Which blood vessels, linked directly to the heart, transport deoxygenated blood?

- A aorta and pulmonary artery
- B aorta and pulmonary vein
- C vena cava and pulmonary artery
- D vena cava and pulmonary vein

15 The diagram shows the right side of the human heart when the ventricle is relaxed.

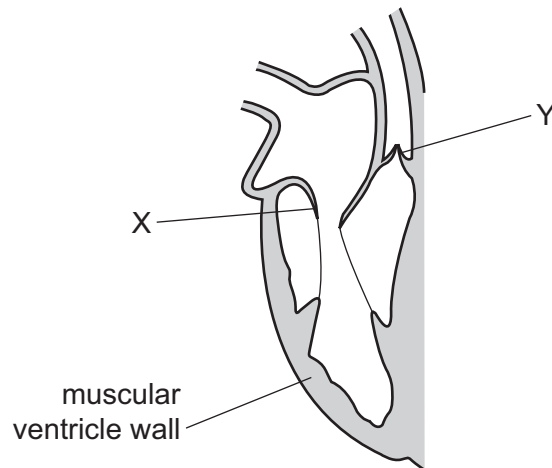

Which row describes the positions of valve X and valve Y when the ventricle contracts?

	valve X	valve Y
A	closed	closed
B	closed	open
C	open	closed
D	open	open

16 Which component of the blood stimulates the formation of fibres to help seal a wound?

- A plasma
- B platelets
- C red blood cells
- D white blood cells

17 The diagram shows a cell.

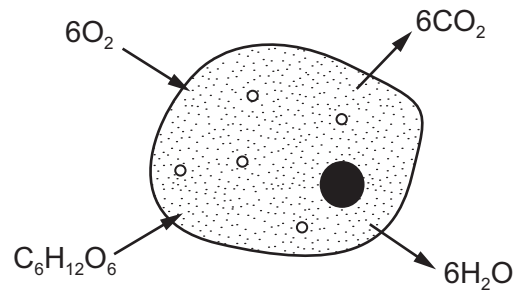

Which process in the cell is represented by the movement of substances shown in the diagram?

- A aerobic respiration
- B anaerobic respiration
- C assimilation
- D photosynthesis

18 Four flasks are sterilised and set up as shown.

Which flask will show signs of fermentation (anaerobic respiration) after one hour?

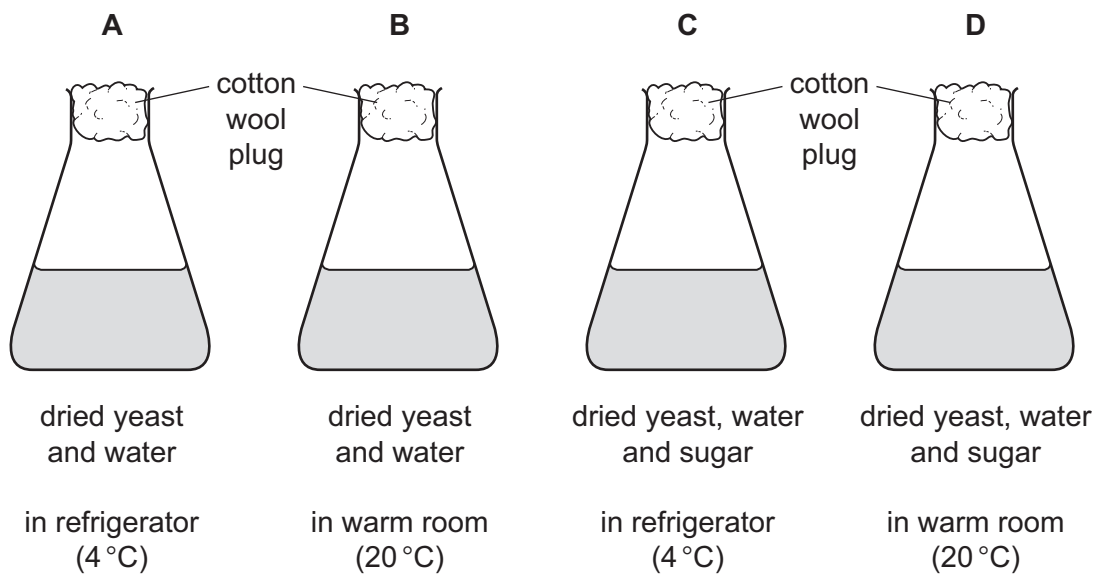

19 The graphs show the depth and rate of breathing in an individual doing four different levels of activity.

The same scale for volume is used in each graph.

Which graph shows the individual being most active?

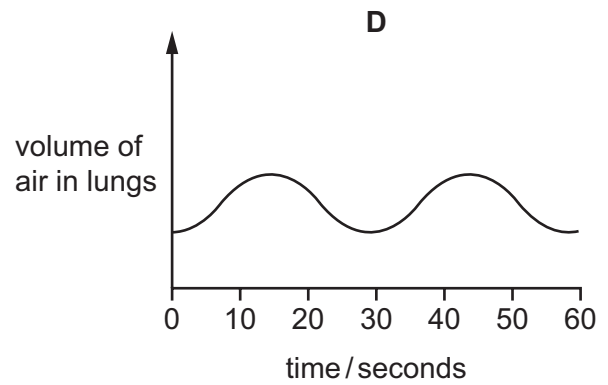
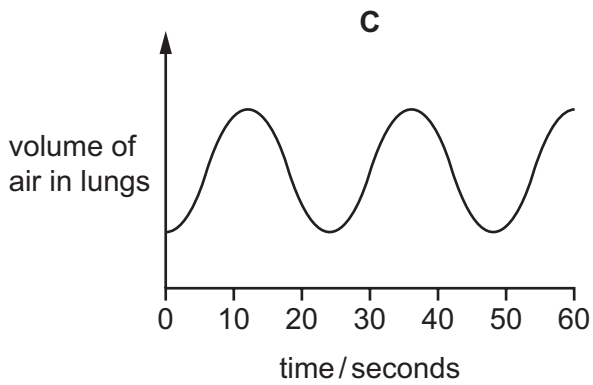
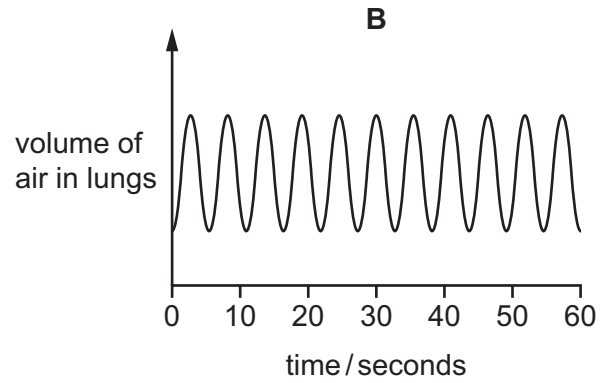
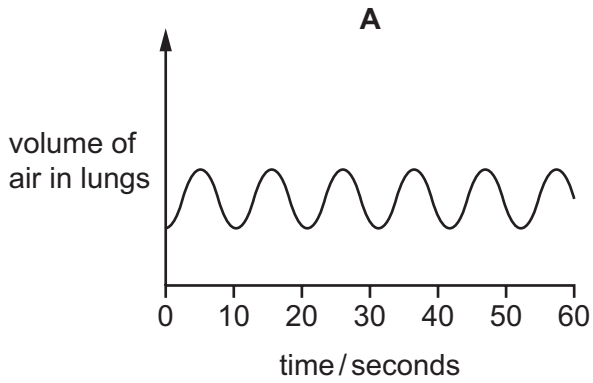

20 Which graph shows the changes in concentration of urea and glucose in the blood during kidney dialysis?

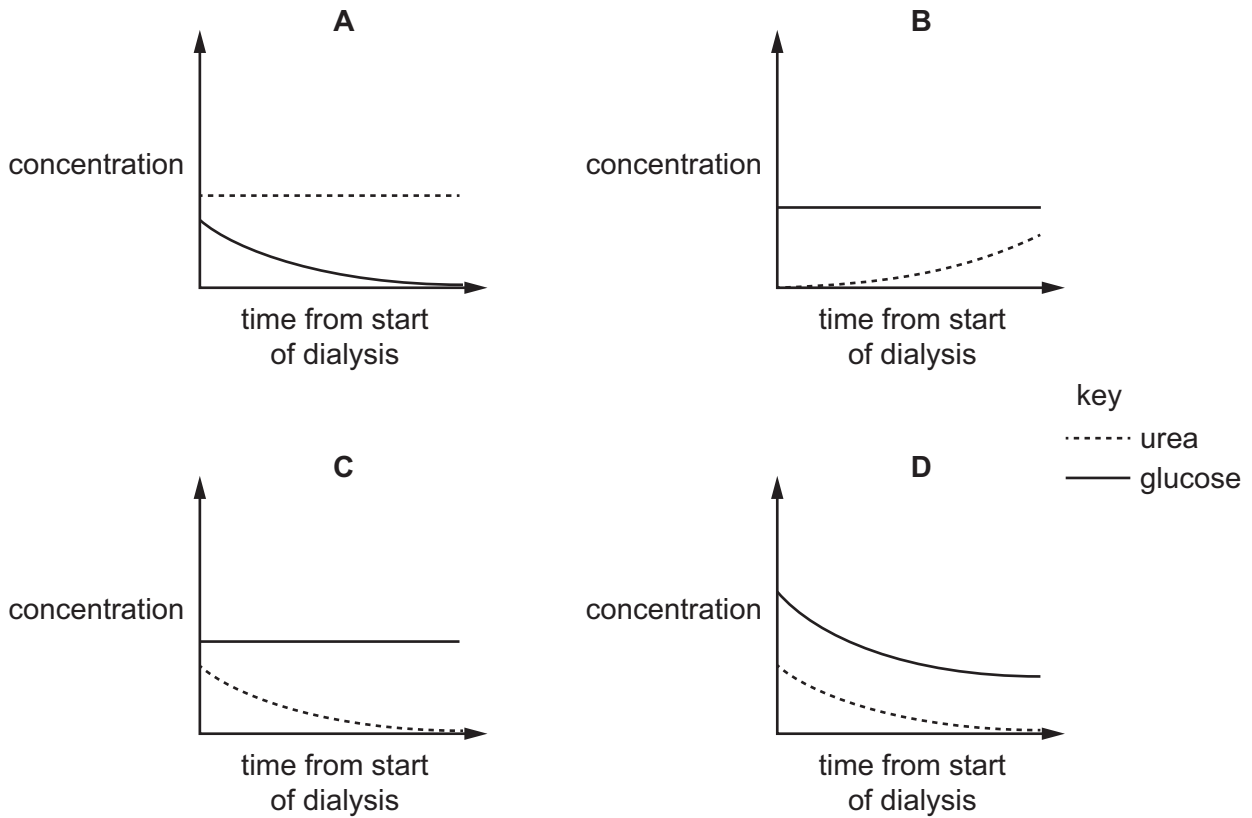

21 The diagram shows a cross-section of the human skin.

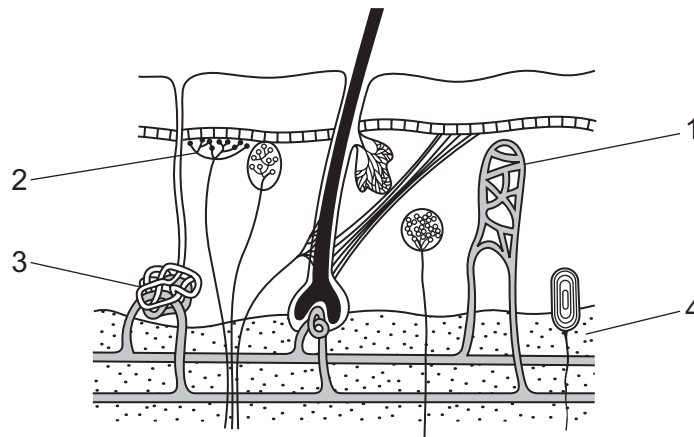

Which structures are involved in maintaining a constant body temperature?

- A** 1 and 2 only **B** 1, 2, 3 and 4 **C** 2 and 3 only **D** 4 only

22 The graph shows changes in a person's body temperature plotted against time.

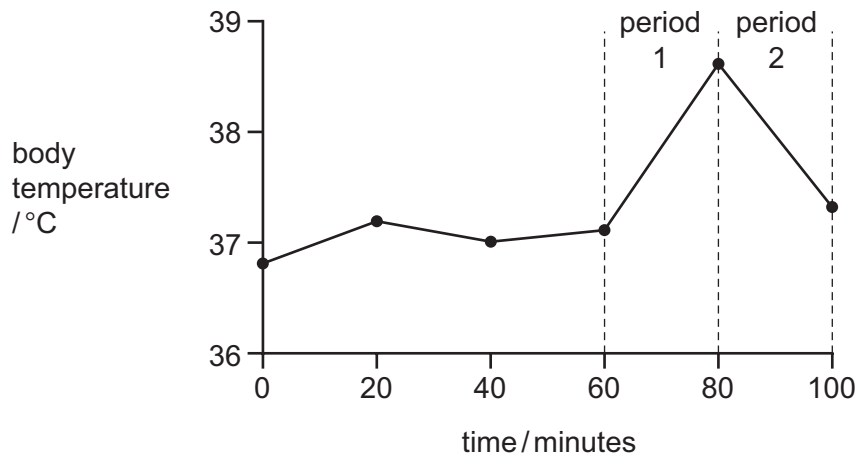

What could cause the changes in body temperature in periods 1 and 2?

	period 1	period 2
A	reduced air temperature	increased air temperature
B	reduced air temperature	shivering
C	vigorous exercise	increased sweating
D	vigorous exercise	shivering

23 The diagram shows a section through the human brain.

Which part of the brain controls the rate of breathing?

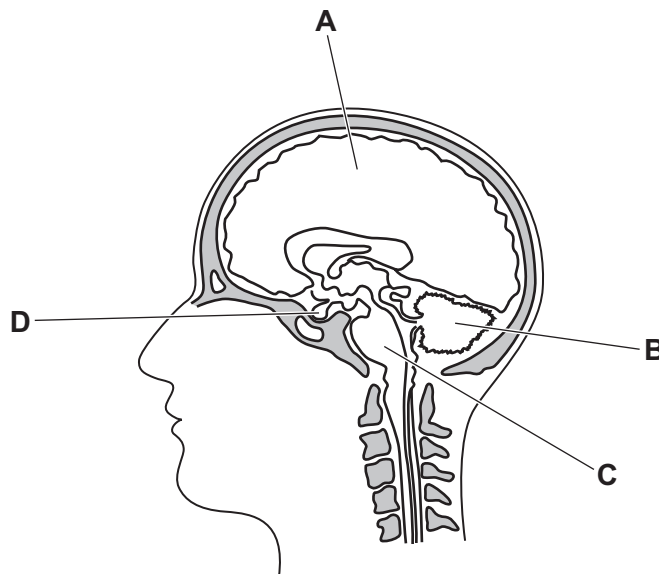

24 Which diagram shows how light from a distant object is focused on the retina to form a clear image?

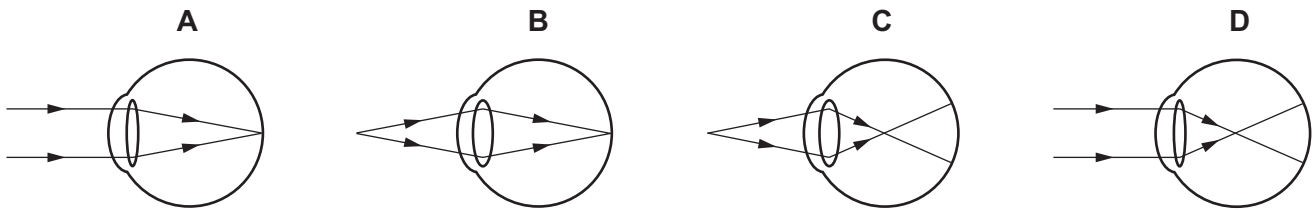

25 Which condition causes an increased blood glucose concentration?

- A a condition causing sufferers to reduce food intake to extreme levels
- B a genetic disorder causing too much insulin to be secreted
- C a condition causing a reduction in the number of red blood cells
- D a condition causing too much adrenaline to be secreted

26 The diagram shows the bones of the human forelimb.

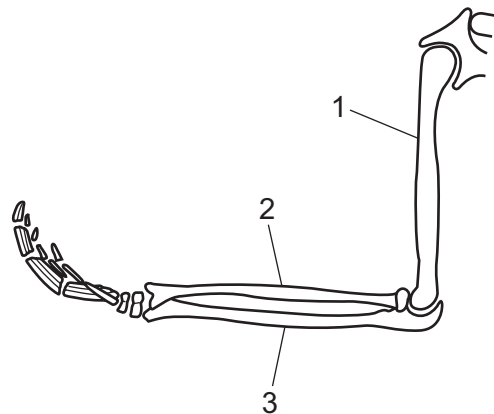

Which row names the three bones?

	1	2	3
A	humerus	ulna	radius
B	humerus	radius	ulna
C	scapula	radius	ulna
D	scapula	ulna	radius

27 Which short-term effect is caused by excessive consumption of alcohol?

- A damage to the tissues of the heart
- B faster transmission of nerve impulses
- C reduced self-control of behaviour
- D shorter reaction times

28 Which row shows the characteristics of viruses?

	act as decomposers	can only reproduce inside a host cell	only seen under an electron microscope	genetic material surrounded by a protein coat	
A	✓	✗	✓	✓	key ✓ = yes ✗ = no
B	✗	✓	✓	✓	
C	✗	✓	✓	✗	
D	✓	✗	✗	✓	

29 The graph shows the mass of *Penicillium* grown in a fermenter and the mass of antibiotic produced.

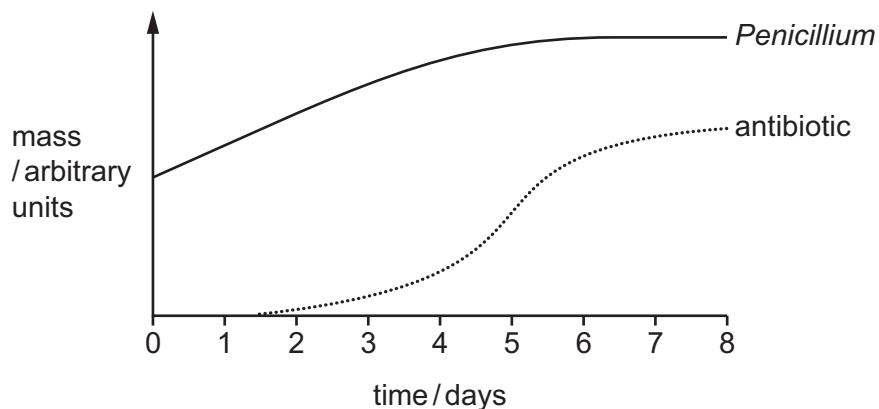

When is the *Penicillium* producing antibiotic most rapidly?

- A day 1
- B day 3
- C day 5
- D day 8

30 The diagram shows part of the carbon cycle.

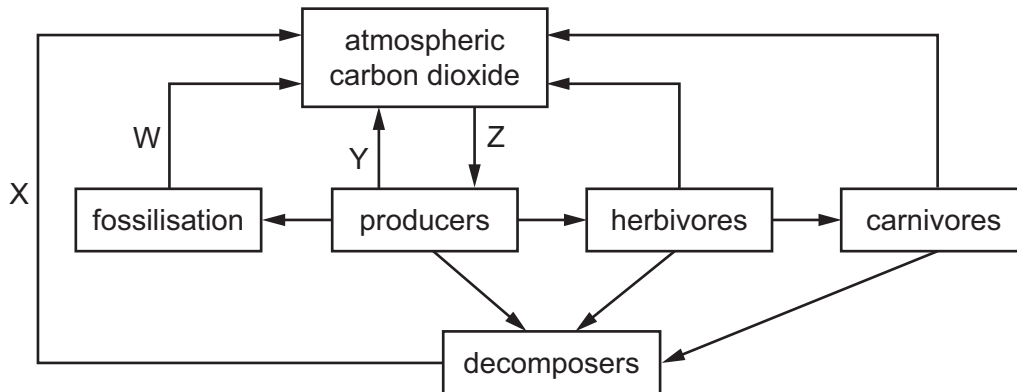

Which row identifies processes W, X, Y and Z?

	W	X	Y	Z
A	combustion	respiration	respiration	photosynthesis
B	combustion	photosynthesis	photosynthesis	respiration
C	respiration	combustion	respiration	photosynthesis
D	respiration	photosynthesis	combustion	photosynthesis

31 An organism such as a mosquito can pass a disease-causing organism from one host to another.

Which term describes the mosquito?

- A** parasite
- B** pathogen
- C** receptor
- D** vector

32 What increases in the long term as a result of tropical deforestation?

- A cloud cover
- B humidity
- C soil erosion
- D soil fertility

33 Which graph shows how the amount of DNA in a cell changes when the cell divides by mitosis?

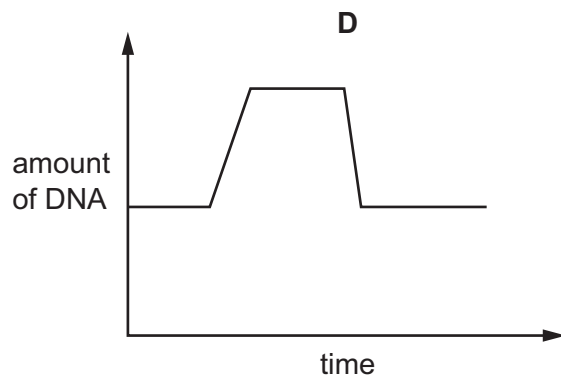
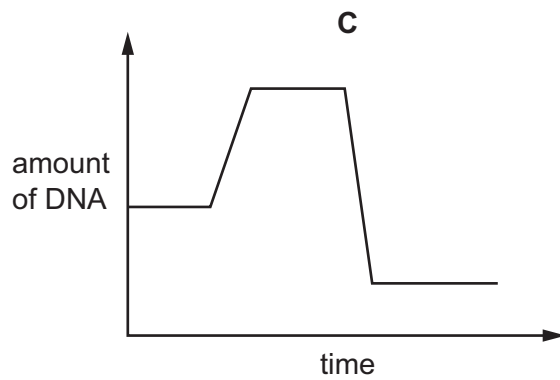
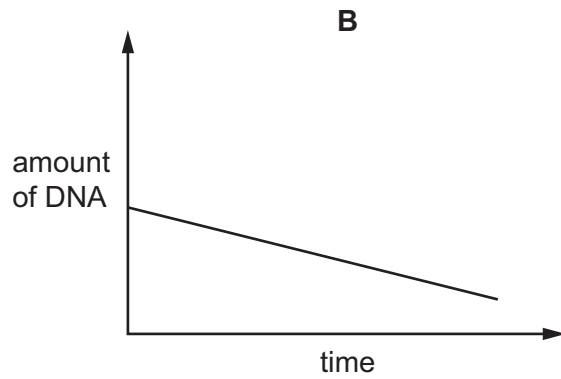
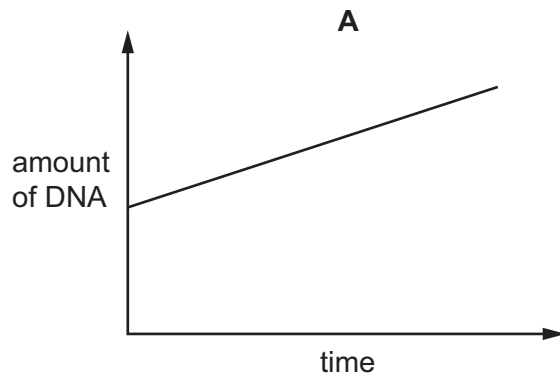

34 The diagram shows the human male reproductive system.

Which structure may contain sperm?

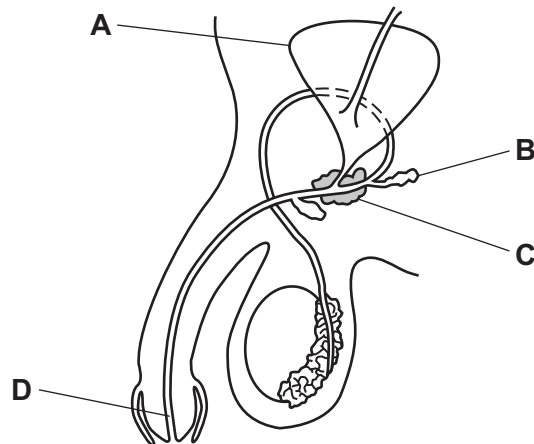

35 Some statements about the human immunodeficiency virus (HIV) are listed.

- 1 Its spread can be reduced by using condoms.
- 2 It can pass across the placenta.
- 3 It can be spread by coughing or sneezing.
- 4 It is the same as AIDS.
- 5 It is transmitted in blood and semen.
- 6 Its spread can be reduced by screening donated blood.

Which statements about HIV are **not** correct?

- A** 1, 3 and 6 **B** 2, 4 and 5 **C** 2 and 3 **D** 3 and 4

36 The diagram shows a developing fetus in the uterus.

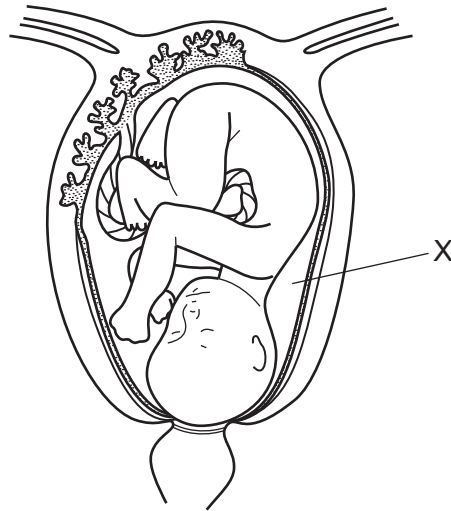

What is the liquid at X called?

- A amniotic fluid
- B blood
- C urine
- D water

37 Which row shows examples of continuous and discontinuous variation in humans?

	continuous variation	discontinuous variation
A	height	blood group
B	blood group	hair colour
C	hair colour	body mass
D	blood group	height

- 38 The diagram shows a family tree for the inheritance of eye colour. The allele for brown eyes is dominant and the allele for blue eyes is recessive.

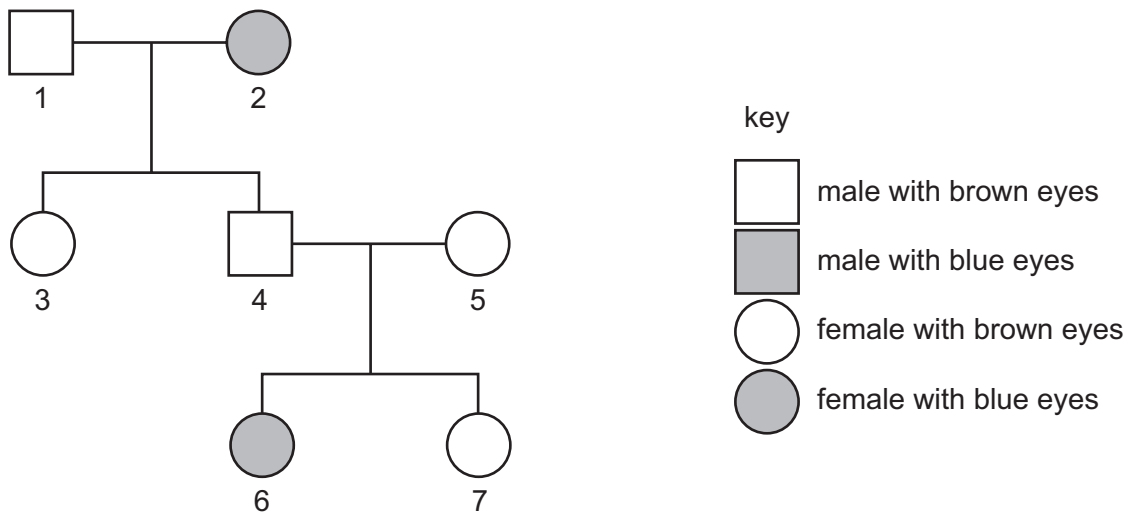

Which people **must** be heterozygous for eye colour?

- A 1, 3 and 7 B 2 and 6 C 3, 4 and 5 D 4 and 5 only
- 39 The number of weed plants in a grass field was counted at monthly intervals. The table shows the results.

weeds	number of plants																
	2020									2021							
	Apr	May	June	July	Aug	Sept	Oct	Nov	Dec	Jan	Feb	Mar	Apr	May	June	July	Aug
groundsel	361	382	400	490	475	400	275	120	60	0	0	5	5	4	4	2	0
dock	688	700	720	710	730	700	700	650	200	0	0	300	150	30	14	6	2
plantain	50	60	80	93	102	140	190	260	200	150	160	350	512	762	840	975	1090
dandelion	75	100	160	202	253	314	335	300	175	20	0	130	414	561	732	849	987

Since August 2020, the field was mown regularly and used as a football pitch.

From this information, which two weeds are best adapted to survive in mown grass?

- A dandelion and dock
 B dock and groundsel
 C plantain and dandelion
 D plantain and dock

40 Stages in the production of insulin on a commercial scale are listed.

- 1 bacteria produce human insulin
- 2 bacteria reproduce
- 3 human insulin gene extracted
- 4 human insulin gene inserted into bacterial DNA
- 5 human insulin produced on a commercial scale

What is the correct sequence of events?

- A** 3 → 4 → 1 → 5 → 2
- B** 4 → 3 → 5 → 2 → 1
- C** 4 → 2 → 5 → 3 → 1
- D** 3 → 4 → 1 → 2 → 5

Permission to reproduce items where third-party owned material protected by copyright is included has been sought and cleared where possible. Every reasonable effort has been made by the publisher (UCLES) to trace copyright holders, but if any items requiring clearance have unwittingly been included, the publisher will be pleased to make amends at the earliest possible opportunity.

To avoid the issue of disclosure of answer-related information to candidates, all copyright acknowledgements are reproduced online in the Cambridge Assessment International Education Copyright Acknowledgements Booklet. This is produced for each series of examinations and is freely available to download at www.cambridgeinternational.org after the live examination series.

Cambridge Assessment International Education is part of Cambridge Assessment. Cambridge Assessment is the brand name of the University of Cambridge Local Examinations Syndicate (UCLES), which is a department of the University of Cambridge.