



**Cambridge International Examinations**  
Cambridge Ordinary Level

---

**BIOLOGY**

**5090/11**

Paper 1 Multiple Choice

**May/June 2014**

**1 hour**

Additional Materials:      Multiple Choice Answer Sheet  
   Soft clean eraser  
   Soft pencil (type B or HB is recommended)

\*  
5  
6  
8  
9  
6  
7  
5  
7  
8  
9  
\*

---

**READ THESE INSTRUCTIONS FIRST**

Write in soft pencil.

Do not use staples, paper clips, glue or correction fluid.

Write your name, Centre number and candidate number on the Answer Sheet in the spaces provided unless this has been done for you.

**DO NOT WRITE IN ANY BARCODES.**

There are **forty** questions on this paper. Answer **all** questions. For each question there are four possible answers **A, B, C** and **D**.

Choose the **one** you consider correct and record your choice in **soft pencil** on the separate Answer Sheet.

**Read the instructions on the Answer Sheet very carefully.**

Each correct answer will score one mark. A mark will not be deducted for a wrong answer.

Any rough working should be done in this booklet.

Electronic calculators may be used.

---

This document consists of **16** printed pages.

1 Which of the following have both cytoplasm and cell walls?

- A liver cells
- B red blood cells
- C root hair cells
- D xylem vessels

2 Plant cells are placed in a solution with a lower water potential than that of the cells.

Which row is correct?

	movement of water by osmosis	volume of vacuole
<b>A</b>	enters cells	decreases
<b>B</b>	enters cells	increases
<b>C</b>	leaves cells	decreases
<b>D</b>	leaves cells	increases

3 Which diagram illustrates the process of active transport?

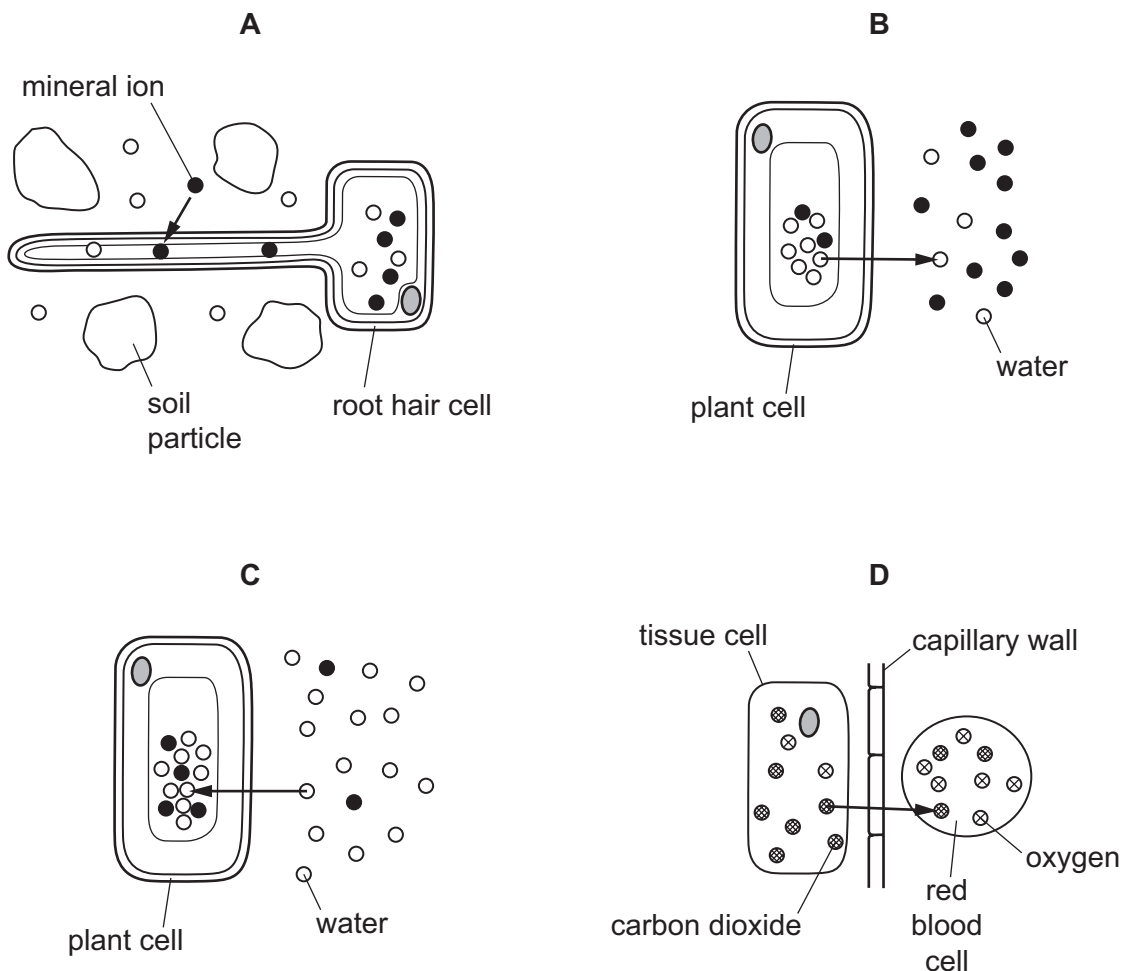

4 A bacterium lives in hot springs at temperatures of 75°C to 85°C.

Which graph represents the activity of enzymes found in these bacteria?

**A**

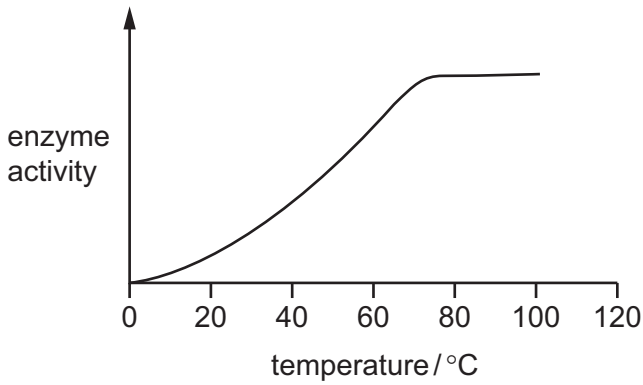

**B**

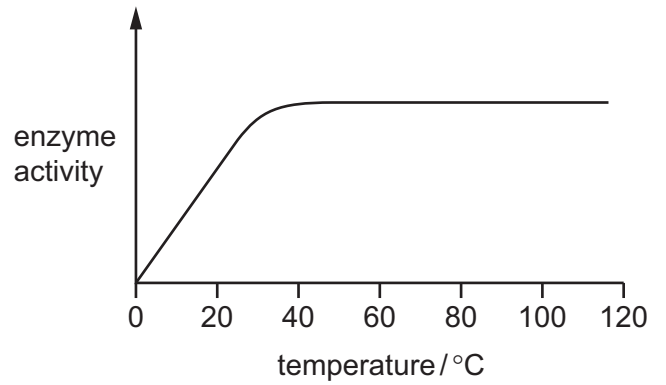

**C**

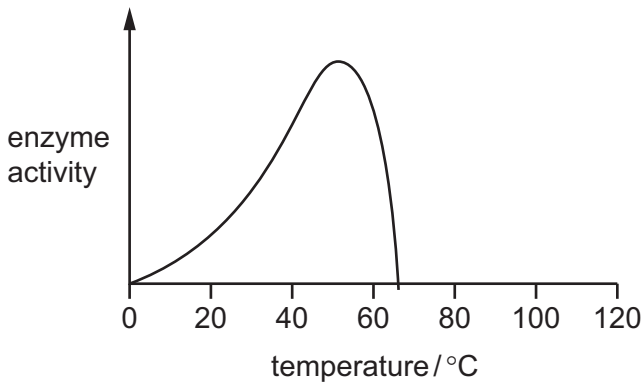

**D**

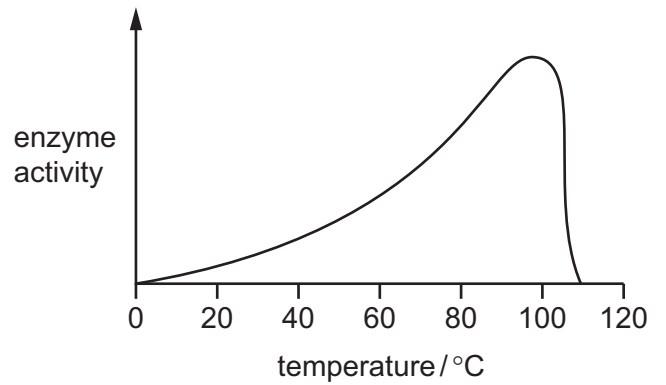

5 The diagram shows the structure of a leaf of a dicotyledonous plant.

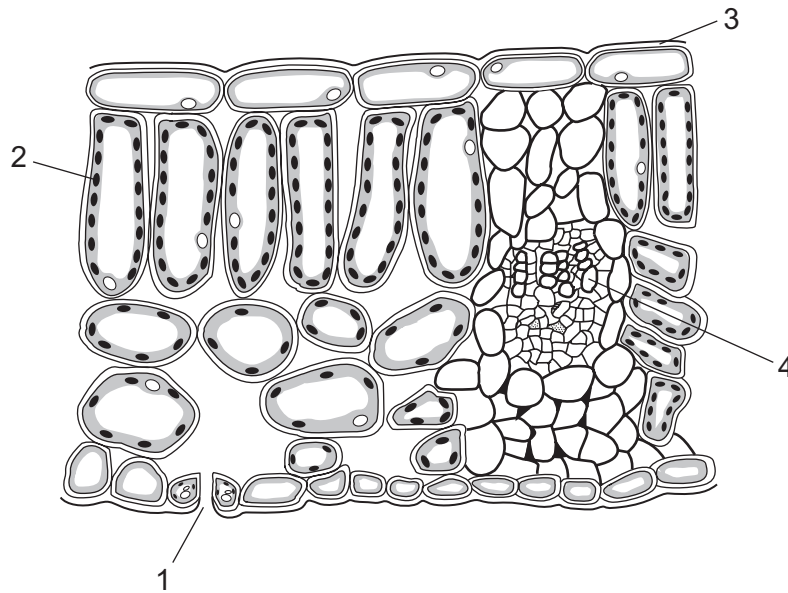

What are the functions of the parts labelled on the diagram?

	1	2	3	4
<b>A</b>	gaseous exchange	photosynthesis	reducing evaporation	transport
<b>B</b>	photosynthesis	gaseous exchange	transport	reducing evaporation
<b>C</b>	photosynthesis	reducing evaporation	gaseous exchange	transport
<b>D</b>	transport	reducing evaporation	gaseous exchange	photosynthesis

6 The diagram refers to some substances found in plant cells.

Which area of the diagram represents the end products of photosynthesis?

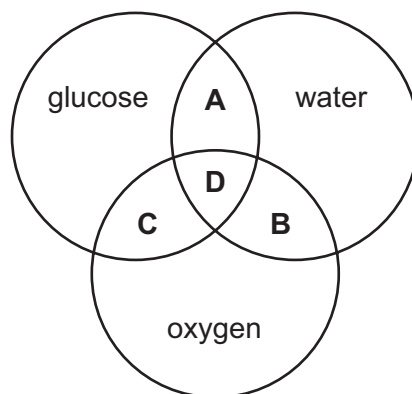

- 7 The diagrams show an experiment to find the rate of photosynthesis in an aquatic plant in different conditions.

Which plant produces the most bubbles per minute?

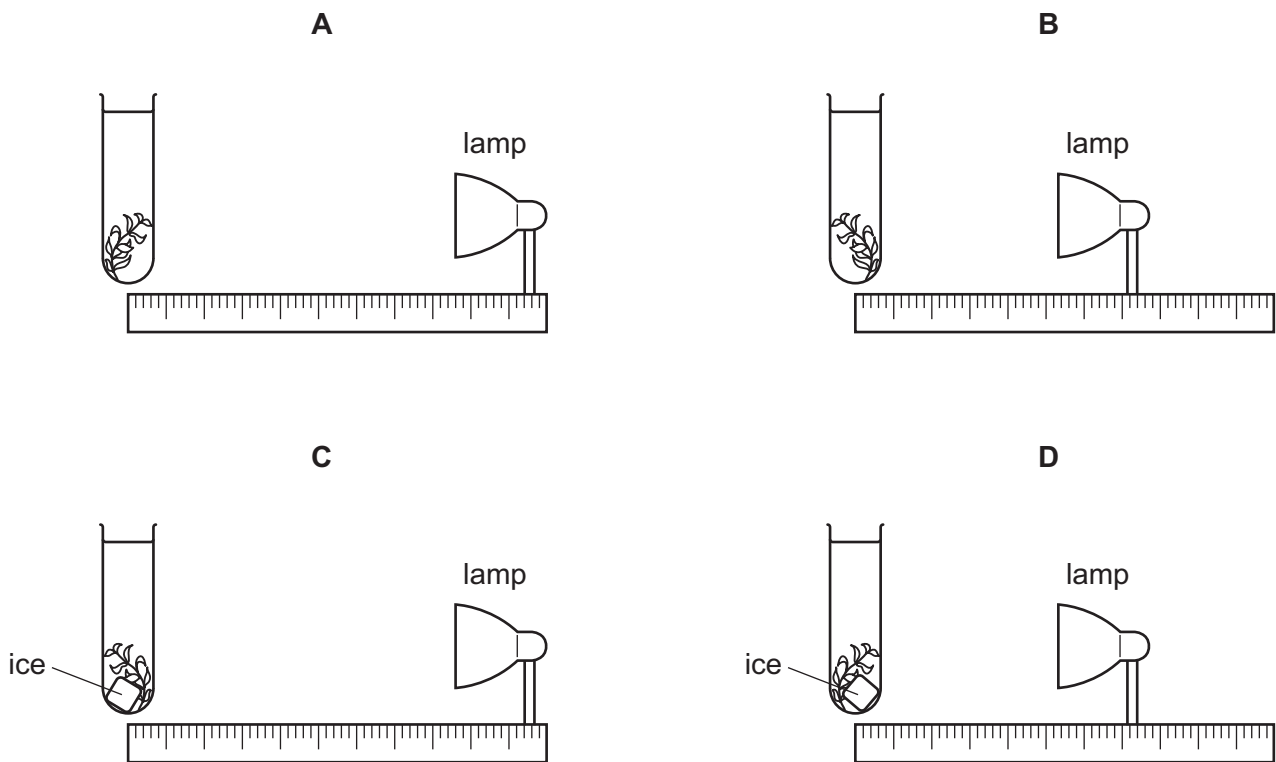

- 8 Which symptom of malnutrition can be treated by an increased amount of protein in the diet?

- A constipation
- B heart disease
- C obesity
- D stunted growth

- 9 The table shows the rates of absorption of two different sugars, arabinose and glucose, in living and dead intestines. The concentrations of the sugars inside the intestines were the same in each case.

	rate of absorption (arbitrary units)	
	arabinose	glucose
living intestine	31	102
dead intestine	31	34

What are the main methods of absorption of arabinose and glucose in living intestine?

	arabinose	glucose
<b>A</b>	active transport	active transport
<b>B</b>	active transport	diffusion
<b>C</b>	diffusion	active transport
<b>D</b>	diffusion	diffusion

- 10 The table describes some characteristics of four people.

Which person requires the highest energy intake in their diet?

	age	sex	level of activity	body weight / kg
<b>A</b>	5	male	high	18
<b>B</b>	20	male	low	85
<b>C</b>	40	female	high	82
<b>D</b>	65	female	low	75

- 11 The diagram shows a section through the stem of a dicotyledonous plant.

Which tissue transports sugars through the stem?

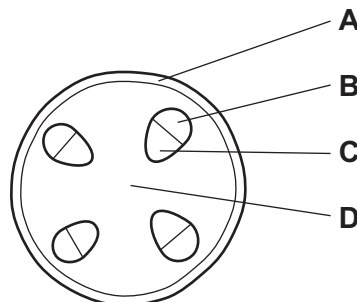

- 12 Which effects will an increase in temperature and an increase in humidity have on the transpiration rate of a plant?

	transpiration rate	
	with increased temperature	with increased humidity
<b>A</b>	decreases	decreases
<b>B</b>	decreases	increases
<b>C</b>	increases	decreases
<b>D</b>	increases	increases

- 13 Which sequence shows the shortest route taken by blood travelling from a leg to an arm in the human body?

- A** leg → heart → lungs → heart → arm  
**B** leg → heart → lungs → kidney → arm  
**C** leg → kidney → heart → lungs → arm  
**D** leg → lungs → heart → alimentary canal → arm

- 14 The diagram shows a section through part of a vein.

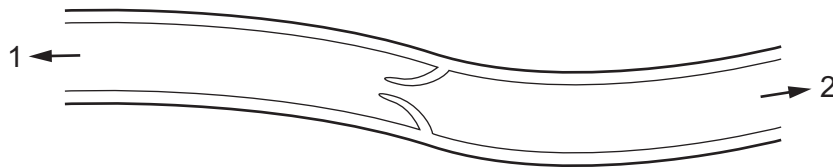

What could be the first organs found in the directions 1 and 2?

	1	2
<b>A</b>	heart	brain
<b>B</b>	intestine	liver
<b>C</b>	kidney	heart
<b>D</b>	lung	heart

- 15 The graph shows the pressure changes in the left atrium and the left ventricle while the heart is beating.

When does the atrio-ventricular (bicuspid) valve close?

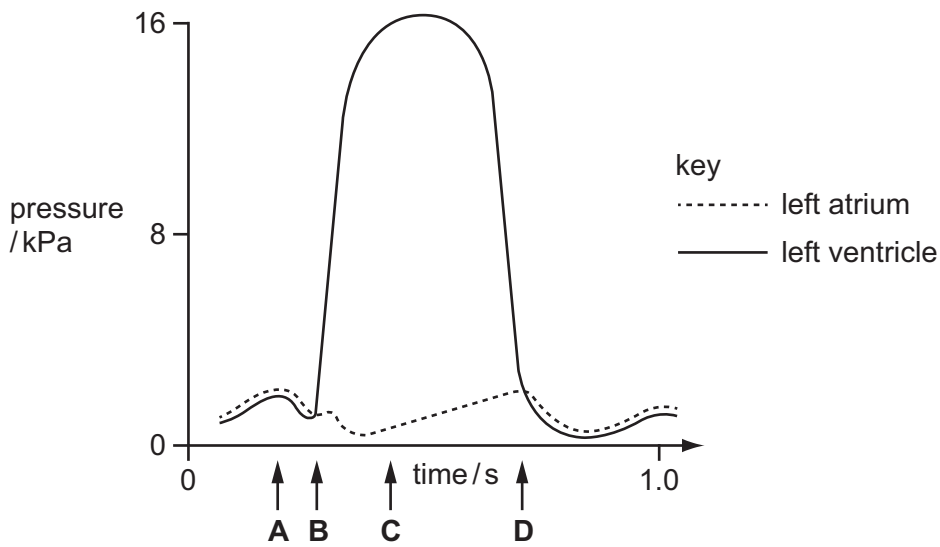

- 16 Anaerobic respiration in yeast can be summarised as follows.

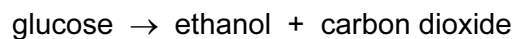

How many molecules of carbon dioxide will be produced from the breakdown of two molecules of glucose?

- A 2                      B 4                      C 6                      D 12

- 17 The diagram shows an alveolus and an associated blood capillary.

At which point will the greatest rate of diffusion of carbon dioxide occur?

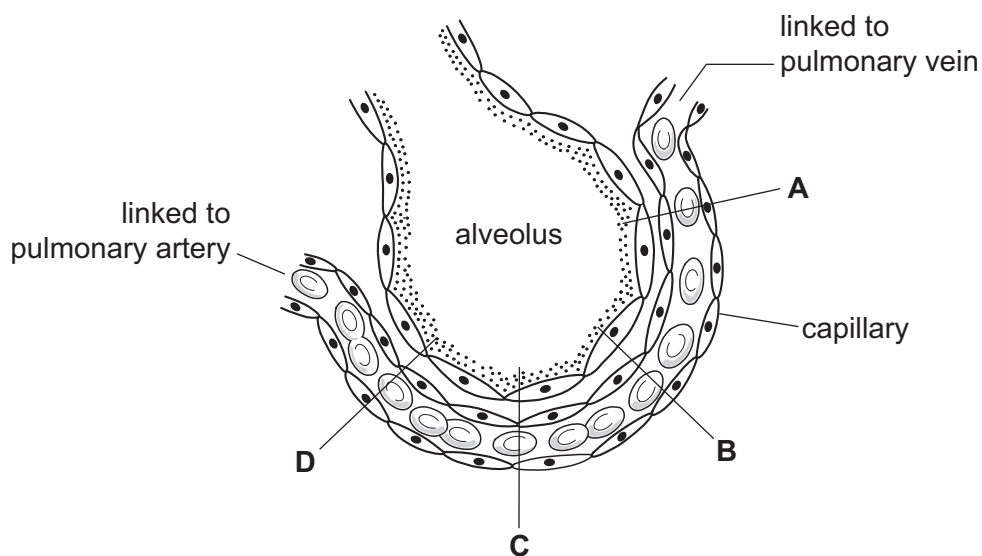



18 What happens to the volume of the thorax and the air pressure in the lungs during breathing out?

	volume of thorax	air pressure in lungs
<b>A</b>	decreases	increases
<b>B</b>	decreases	remains constant
<b>C</b>	increases	increases
<b>D</b>	increases	remains constant

19 Which process occurs in a kidney dialysis machine?

- A** Large protein molecules are removed from the blood plasma.
- B** Materials pass out of the blood down a concentration gradient.
- C** Oxygen is used up in removing materials from the blood.
- D** Pressure forces dialysis fluid into the blood.

20 What happens when the body temperature rises above normal?

	arterioles near skin surface	sweat secreted
<b>A</b>	constricted	yes
<b>B</b>	constricted	no
<b>C</b>	dilated	yes
<b>D</b>	dilated	no

- 21 A man stands 10 metres away from a sign and can see it clearly. He walks towards the sign and stops 0.5 metres from it.

Which changes occur in his eyes so that the sign is still in focus?

	ciliary muscles	suspensory ligaments	lens becomes	result is light rays refracted
<b>A</b>	contract	slacken	thicker	more
<b>B</b>	contract	tighten	thinner	less
<b>C</b>	relax	slacken	thinner	less
<b>D</b>	relax	tighten	thicker	more

- 22 The diagram shows a section through the brain.

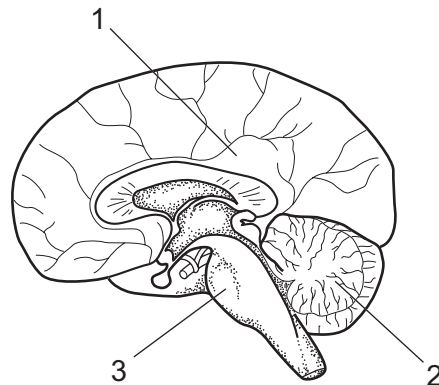

What are some functions of the parts labelled 1, 2 and 3?

	1	2	3
<b>A</b>	centre for learning	forms visual images	controls digestion
<b>B</b>	controls blood pressure	centre for touch sensations	controls breathing rate
<b>C</b>	controls speech	controls smooth movements	controls heart rate
<b>D</b>	forms memory store	controls balance	determines intelligence

23 How does adrenaline affect glucose uptake by muscle cells and carbohydrate conversion by liver cells?

	glucose uptake	carbohydrate conversion
<b>A</b>	decreases	glucose to glycogen
<b>B</b>	decreases	glycogen to glucose
<b>C</b>	increases	glucose to glycogen
<b>D</b>	increases	glycogen to glucose

24 The diagrams show the bones of the forelimb in a bat and in a human.

Which structure in the forelimb of the bat can be identified as the humerus?

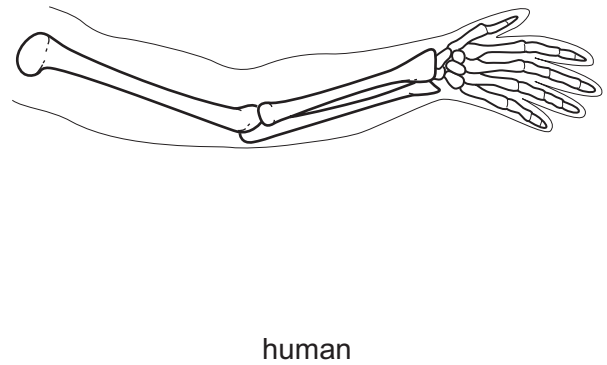
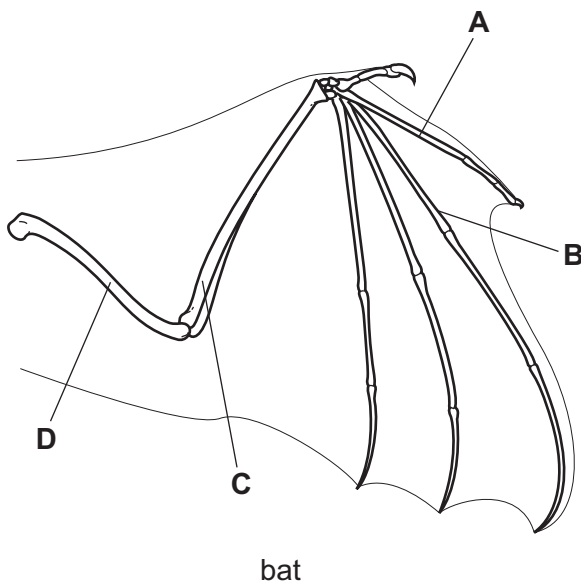

- 25 The bar chart shows the percentage of women who had babies of low weight, amongst smokers and non-smokers.

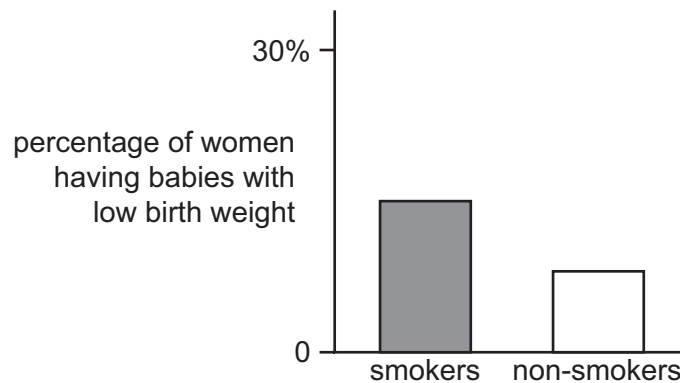

What is shown by the bar chart?

- A** More women smoke during pregnancy than do not.
- B** Smoking in pregnancy increases the risk of low birth weight.
- C** Smoking is bad for the health of a pregnant woman.
- D** Women whose babies have low birth weight are smokers.
- 26 Which substances are produced using bacteria?
- A** cheese and yoghurt
- B** cheese and penicillin
- C** penicillin and bread
- D** yoghurt and bread
- 27 Using the key, which organism is a virus?
- 1 has a cell wall ..... go to 2  
does not have a cell wall ..... go to 3
- 2 cell wall is made of chitin ..... organism **A**  
cell wall is made of cellulose ..... organism **B**
- 3 has a cell membrane ..... organism **C**  
has a protein coat ..... organism **D**
- 28 Which statement correctly describes relationships in ecosystems?
- A** Carbohydrates are passed from decomposers to producers.
- B** Energy is passed from carnivores to herbivores.
- C** Proteins are passed from primary consumers to producers.
- D** Water is passed from respiring decomposers to producers.

29 The diagram shows a food chain.

grass → rabbit → fox → flea

Which pyramid of numbers matches this food chain?

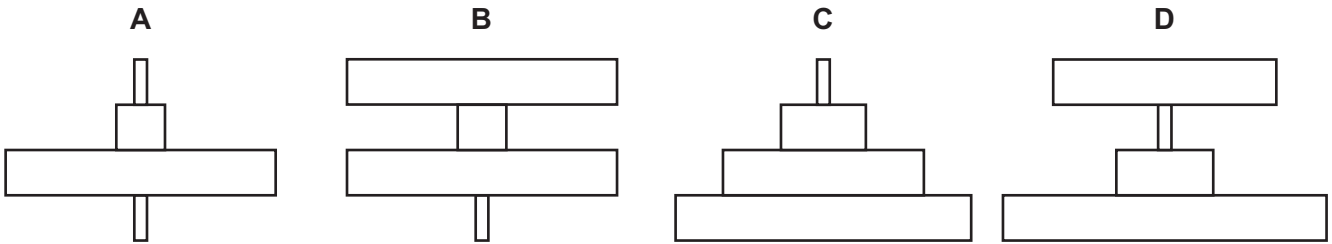

30 In which natural cycles are protein molecules involved?

	carbon cycle	nitrogen cycle
<b>A</b>	✓	✓
<b>B</b>	✓	x
<b>C</b>	x	✓
<b>D</b>	x	x

31 Why is the organism that causes malaria called both a parasite and a pathogen?

	called a parasite because	called a pathogen because
<b>A</b>	it feeds on its host	it causes disease
<b>B</b>	it feeds on its host	it lives inside another organism
<b>C</b>	it is carried by a vector	it causes disease
<b>D</b>	it is carried by a vector	it lives inside another organism

32 The list shows some changes that may occur in a lake that is polluted with nitrogen-containing fertiliser.

- 1 Concentration of oxygen decreases.
- 2 Decomposers feed on plants.
- 3 Green microorganisms grow and cover the surface.
- 4 Plants die.

In which order do these changes occur?

- A** 1 → 2 → 3 → 4
- B** 2 → 1 → 4 → 3
- C** 3 → 4 → 2 → 1
- D** 4 → 3 → 1 → 2
- 33 What are two female parts of a flower?

- A** anther and seed
- B** sepal and petal
- C** stamen and carpel
- D** stigma and carpel

34 Cell X contains 24 chromosomes. It divides by mitosis to produce cells Y and Z.

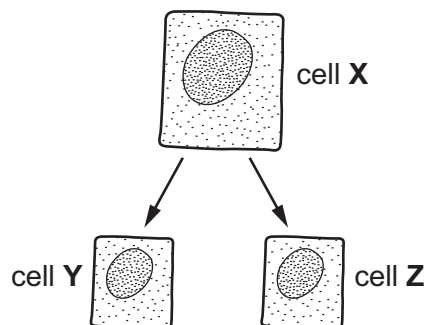

How many chromosomes does cell Z contain?

- A** 12                      **B** 24                      **C** 46                      **D** 48

35 The graph shows the concentration of a hormone in the blood during one menstrual cycle.

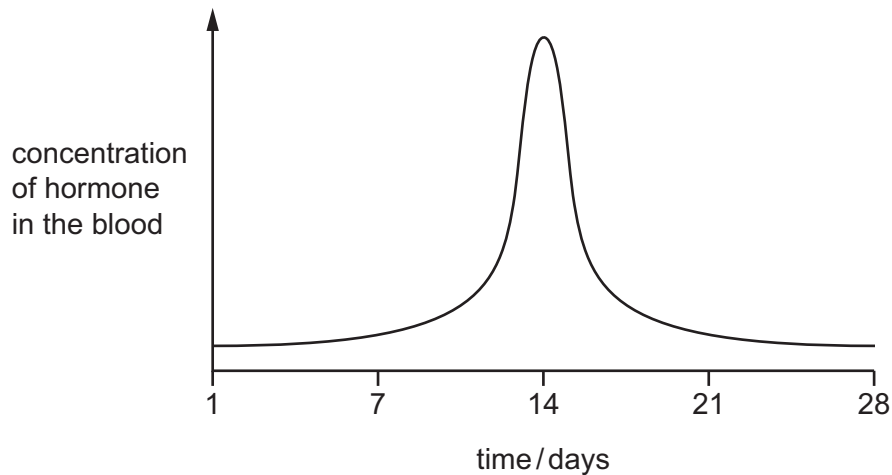

Which hormone concentration was measured?

- A follicle-stimulating hormone
  - B luteinising hormone
  - C oestrogen
  - D progesterone
- 36 Which substances are present in breast milk but **not** in bottled milk made from milk powder?
- A antibodies
  - B carbohydrates
  - C proteins
  - D vitamins
- 37 Which outcomes might farmers want to achieve by using artificial selection?

	increased	decreased
<b>A</b>	fertiliser use	pesticide use
<b>B</b>	growth rate	yield
<b>C</b>	pesticide use	growth rate
<b>D</b>	yield	fertiliser use

38 The diagram shows the blood group phenotypes of some members of a family.

Which member of the F1 generation must be heterozygous, with the codominant alleles?

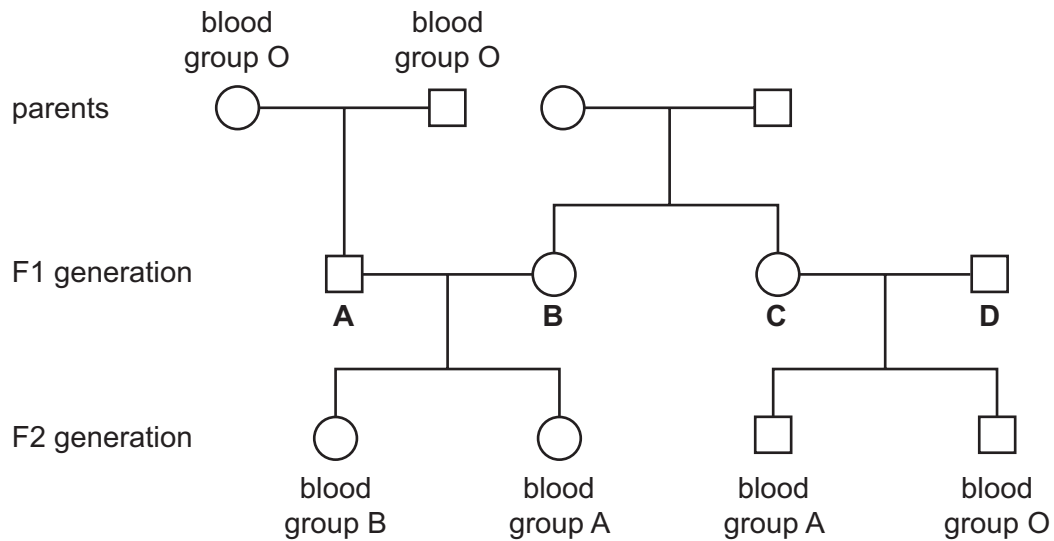

39 Which statement about chromosomes is correct?

- A Chromosomes are long DNA molecules called genes which are divided into sections.
- B Chromosomes include a long molecule of DNA divided into sections called genes.
- C Chromosomes include genes which are divided into sections called DNA molecules.
- D Genes include long DNA molecules called chromosomes.

40 Which statement is **always** true of dominant alleles?

- A They cannot undergo mutation.
- B They give a greater chance of survival than recessive alleles.
- C They give the same phenotype in heterozygotes and homozygotes.
- D They occur more frequently in the population than recessive alleles.