



UNIVERSITY OF CAMBRIDGE INTERNATIONAL EXAMINATIONS
General Certificate of Education Ordinary Level

CANDIDATE
NAME

CENTRE
NUMBER

--	--	--	--	--	--

CANDIDATE
NUMBER

--	--	--	--	--

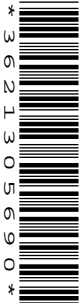

BIOLOGY

5090/06

Paper 6 Alternative to Practical

May/June 2007

1 hour

Candidates answer on the Question Paper.

No Additional Materials are required

READ THESE INSTRUCTIONS FIRST

Write your Centre number, candidate number and name on all work you hand in.

Write in dark blue or black pen.

Do not use staples, paper clips, highlighters, glue or correction fluid.

DO NOT WRITE ON ANY BARCODES.

Answer **all** questions.

At the end of the examination, fasten all your work securely together.

You may use a pencil for any diagrams, graphs or rough working.

The number of marks is given in brackets [] at the end of each question or part question.

For Examiner's Use	
1	
2	
Total	

This document consists of **9** printed pages and **3** blank pages.



BLANK PAGE

- 1 The human body maintains a constant temperature, regardless of the external temperature even though heat may be transferred to and from the environment.

Fig. 1.1 shows the apparatus a student used to investigate heat transfer.

For
Examiner's
Use

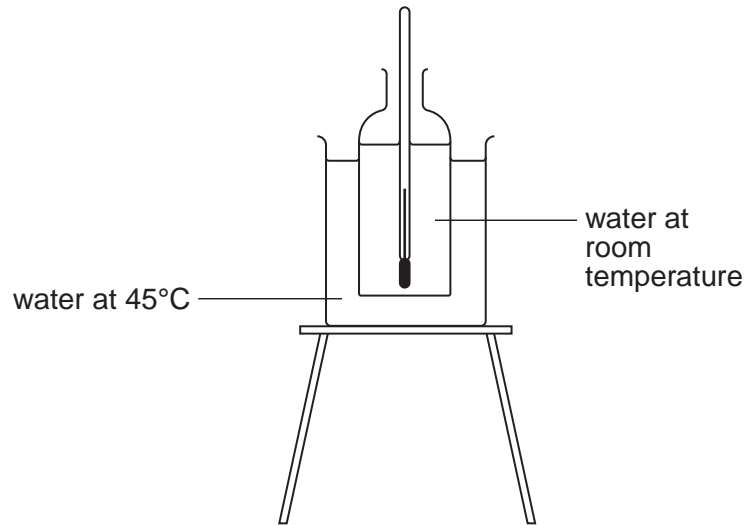

Fig. 1.1

- As soon as the apparatus had been set up, the student immediately measured and recorded the temperature of the water in the bottle and then again every two minutes for the next ten minutes.
- The student then replaced the water in the bottle and beaker and fitted some plastic tubing into the bottle as shown in Fig. 1.2.

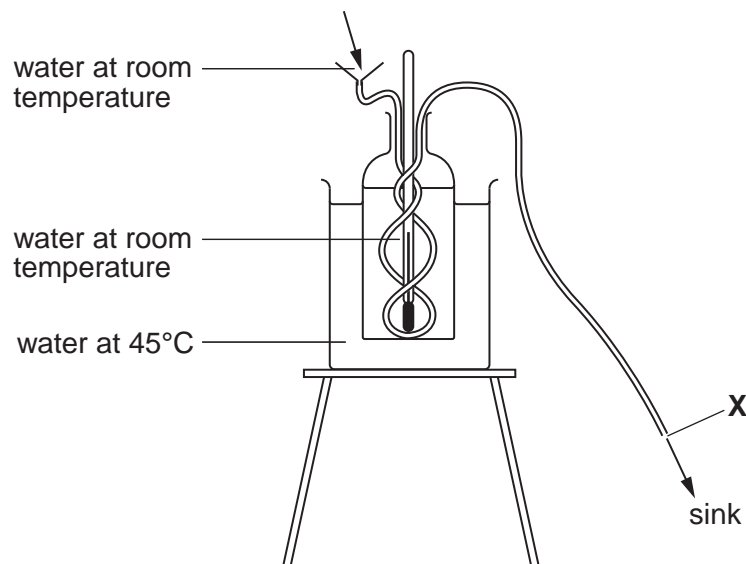

Fig. 1.2

- A steady stream of water at room temperature was poured through the funnel and tubing.
- As soon as the apparatus had been set up, the student immediately measured and recorded the temperature of the water in the bottle and then again every two minutes for the next ten minutes.

- (a) These are the records the student made.

For
Examiner's
Use

First experiment

Starting temperature 20 degrees Celsius.

After two minutes 29

Four minutes 34

Six minutes 37

Eight minutes 39

Ten minutes 40

Second experiment

Starting temperature 20 degrees Celsius.

After two minutes 24

Four minutes 28

Six minutes ??

Eight minutes 32

Ten minutes 34

- (i) Draw a table of the student's results.

[4]

(ii) Plot the results of both experiments on the same axes on the grid below.

For
Examiner's
Use

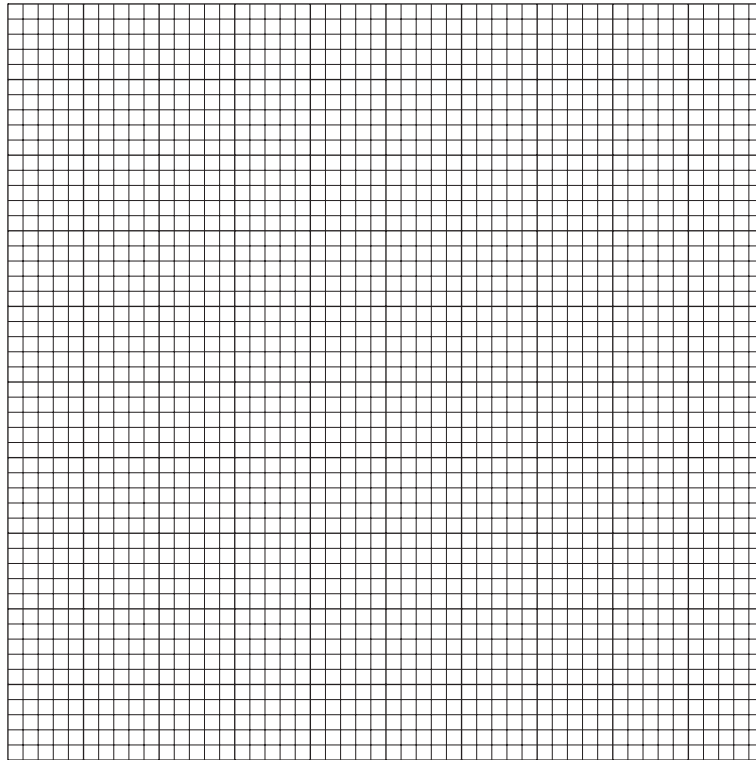

[4]

(iii) The student's result after six minutes is missing from the second experiment. Estimate the missing reading from the graph.

.....[1]

(iv) State and explain the difference in the temperatures in the bottle after 10 minutes.

difference.....

explanation

.....

.....

.....

.....

.....

.....[4]

(b) The plastic bottle in the experiment represents the human body.

(i) State why the water in the bottle should have been at 37 °C .

.....
.....[1]

(ii) Suggest why the bottle should have been gently moved around in the beaker between readings.

.....
.....[1]

(iii) Describe how you would read the thermometer to ensure that your readings were accurate.

.....
.....[1]

(c) The water in the beaker in Fig. 1.2 represents a hot environment.
The bottle and tubing represent a human body.
If the water being poured into the funnel represents cold drinking water,

(i) Suggest what the water leaving the tube at X could represent,

.....[1]

(ii) Suggest how this helps to cool the body.

.....[1]

- 2 A student was provided with four leaves labelled **A**, **B**, **C** and **D** which were initially all of the same size and from the same plant.

Leaf **A** had been freshly picked and had received no treatment.

Leaf **B** had been picked three days before.

Leaf **C** had been picked three days before and its **upper** surface coated immediately with petroleum jelly.

Leaf **D** had been picked three days before and its **lower** surface coated immediately with petroleum jelly.

Leaves **B**, **C** and **D** had been left by a window in the laboratory since being picked.

For
Examiner's
Use

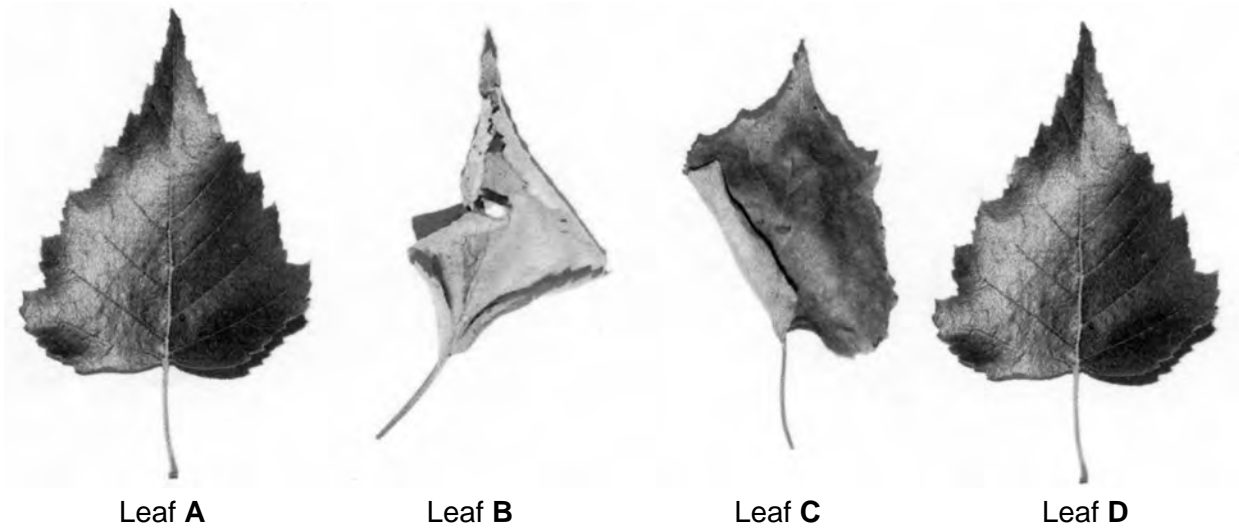

Fig. 2.1

- (a) (i) Make a large, labelled drawing of leaf **A**.

[3]

(ii) Measure and record the width of the picture of leaf **A** at its widest point.

width of leaf

Draw a straight line across the widest point of your drawing of leaf **A**.
Measure and record the length of your line.

length of line [2]

(iii) Calculate the magnification of your drawing.
Show your working.

magnification [2]

(b) Examine leaves **B**, **C** and **D** in Fig. 2.1 and describe their appearance.

(i) leaf **B**

.....

leaf **C**

.....

leaf **D**

..... [3]

(ii) Suggest a reason for the difference in appearance between:

Leaf **B** and **C**

.....

Leaf **C** and **D**

..... [2]

- (c) The student was also provided with a leaf stalk from a different plant that had been left to stand in a liquid stain for several hours.
Fig. 2.2 shows the leaf stalk cut across its width.

For
Examiner's
Use



Fig. 2.2

- (i) Make a large labelled diagram of the cut surface.

[3]

- (ii) Suggest where in Leaf A you might find a similar tissue to that which is stained in (c)(i).

.....[1]

- (iii) Draw a simple diagram of a transverse section of a root and indicate where the same tissue that is stained in the leaf stalk would be found.

[1]

[Total : 17]

[Paper total : 40]

BLANK PAGE

BLANK PAGE

Permission to reproduce items where third-party owned material protected by copyright is included has been sought and cleared where possible. Every reasonable effort has been made by the publisher (UCLES) to trace copyright holders, but if any items requiring clearance have unwittingly been included, the publisher will be pleased to make amends at the earliest possible opportunity.

University of Cambridge International Examinations is part of the Cambridge Assessment Group. Cambridge Assessment is the brand name of University of Cambridge Local Examinations Syndicate (UCLES), which is itself a department of the University of Cambridge.