



# Cambridge O Level

CANDIDATE NAME

CENTRE NUMBER

CANDIDATE NUMBER



**PHYSICS** **5054/32**  
 Paper 3 Practical Test **October/November 2022**  
**2 hours**

You must answer on the question paper.

You will need: The materials and apparatus listed in the confidential instructions

## INSTRUCTIONS

- Answer **all** questions.
- Use a black or dark blue pen. You may use an HB pencil for any diagrams or graphs.
- Write your name, centre number and candidate number in the boxes at the top of the page.
- Write your answer to each question in the space provided.
- Do **not** use an erasable pen or correction fluid.
- Do **not** write on any bar codes.
- For each of the questions in Section A, you will be allowed to work with the apparatus for a maximum of 20 minutes. For the question in Section B, you will be allowed to work with the apparatus for a maximum of 1 hour.
- You should record all your observations in the spaces provided in the question paper as soon as these observations are made.
- You may use a calculator.
- You should show all your working and use appropriate units.

## INFORMATION

- The total mark for this paper is 30.
- The number of marks for each question or part question is shown in brackets [ ].

For Examiner's Use	
<b>1</b>	
<b>2</b>	
<b>3</b>	
<b>4</b>	
<b>Total</b>	

This document has **12** pages. Any blank pages are indicated.

**Section A**

Answer all the questions in this section.

1 In this experiment you will investigate factors affecting friction.

You are provided with:

- a block of wood with a small nail at one end
- a spring attached to a loop of thread
- a ruler kept in place on the bench with a small amount of adhesive putty
- $2 \times 100\text{g}$  masses on the block of wood and two other  $100\text{g}$  masses.

The supervisor has arranged the apparatus as shown in Fig. 1.1.

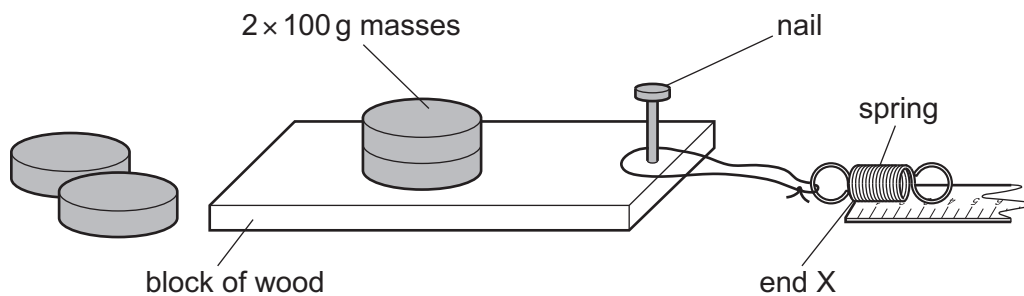

**Fig. 1.1**

Rearrange the apparatus so that the end X of the spring is lined up with the zero end of the scale on the ruler as shown in Fig. 1.2. The string loop between the nail and the spring should be as straight as possible.

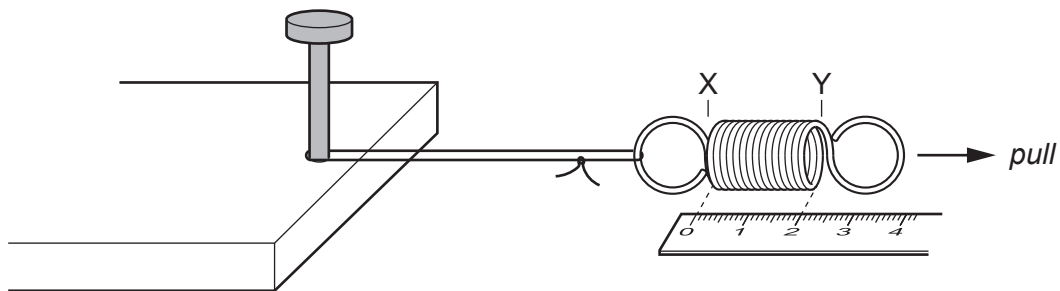

**Fig. 1.2**

Slowly pull end Y of the spring in the direction shown in Fig. 1.2.

Observe that the spring extends until the pulling force overcomes the friction between the block and the bench.

At this point the block will slide a small distance in the direction of the pulling force. Stop pulling the spring, holding end Y at its new position on the scale.

End X of the spring is now also at a new position on the scale.

(a) Record the readings  $x$  and  $y$  where:

- $x$  is the new position on the scale of end X of the spring
- $y$  is the new position on the scale of end Y of the spring.

$x =$  ..... mm

$y =$  ..... mm [1]

(b) A student claims that  $x$  is directly proportional to  $y$ .

Plan an experiment to find out if the student's claim is correct.

In your plan you should:

- state **two** quantities that you will keep constant
- describe how you will obtain different values of  $x$  and  $y$
- describe how the results will show if the student's claim is correct.

You do **not** have to do this experiment.

.....

.....

.....

.....

.....

.....

.....

.....

.....

.....

.....

.....

.....

.....

..... [4]

[Total: 5]

2 In this experiment you will investigate the rate of energy loss from a beaker of hot water.

You are provided with:

- a 250 cm<sup>3</sup> beaker
- a card with the mass of the beaker written on it
- a second beaker to use when pouring hot water
- paper towels to mop up any spilled water
- a thermometer
- a stand, boss and clamp to support the thermometer
- a stop-watch.

The supervisor has set up the apparatus as shown in Fig. 2.1.

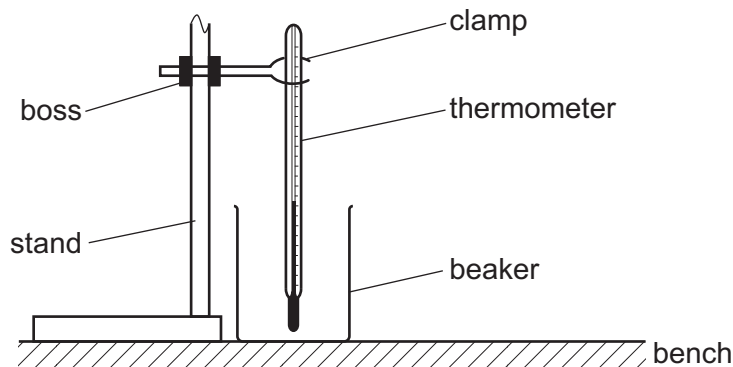

Fig. 2.1

(a) You are going to measure the time taken for the temperature of the water to decrease by 10 °C.

Ask your supervisor to fill your second beaker with hot water.

**Carefully** pour the hot water into the beaker underneath the thermometer up to the 100 cm<sup>3</sup> mark.

First, observe the temperature rise to a maximum on the thermometer.

Start the stop-watch when the temperature just begins to fall.

Stop the stop-watch when the temperature is 10 °C lower than at the start maximum.

Record the reading  $t$  on the stop-watch in seconds.

$t = \dots\dots\dots$  s [1]

(b) Calculate the rate of temperature change  $R$  using the equation:

$$R = \frac{10}{t}.$$

$R = \dots\dots\dots$  °C/s [1]

- (c) The mass  $M$  of the water in the beaker is 100g.

The mass  $m$  of the beaker is written on the card.

Record  $m$ .

$$m = \dots\dots\dots \text{g}$$

Calculate the rate of thermal energy loss from the water and beaker  $P$  using the equation:

$$P = R (Mc_w + mc_g)$$

where the specific heat capacity of water  $c_w$  is  $4.2 \text{ J/(g } ^\circ\text{C)}$   
and the specific heat capacity of glass  $c_g$  is  $0.67 \text{ J/(g } ^\circ\text{C)}$ .

Show your working. Give a unit for your answer.

$$P = \dots\dots\dots [2]$$

- (d) A student suggests that for any value of  $R$ , the correct value of  $P$  will be less than that calculated in (c).

Observe the arrangement of the apparatus and state **one** reason why the student may be correct.

.....  
..... [1]

[Total: 5]

3 In this experiment you will investigate the image produced by a lens.

You are provided with:

- a lens
- a sheet of graph paper
- a stand, boss and clamp to support the lens
- a metre rule
- a weight or G-clamp to stop the stand from toppling over.

The supervisor has set up the apparatus as shown in Fig. 3.1.

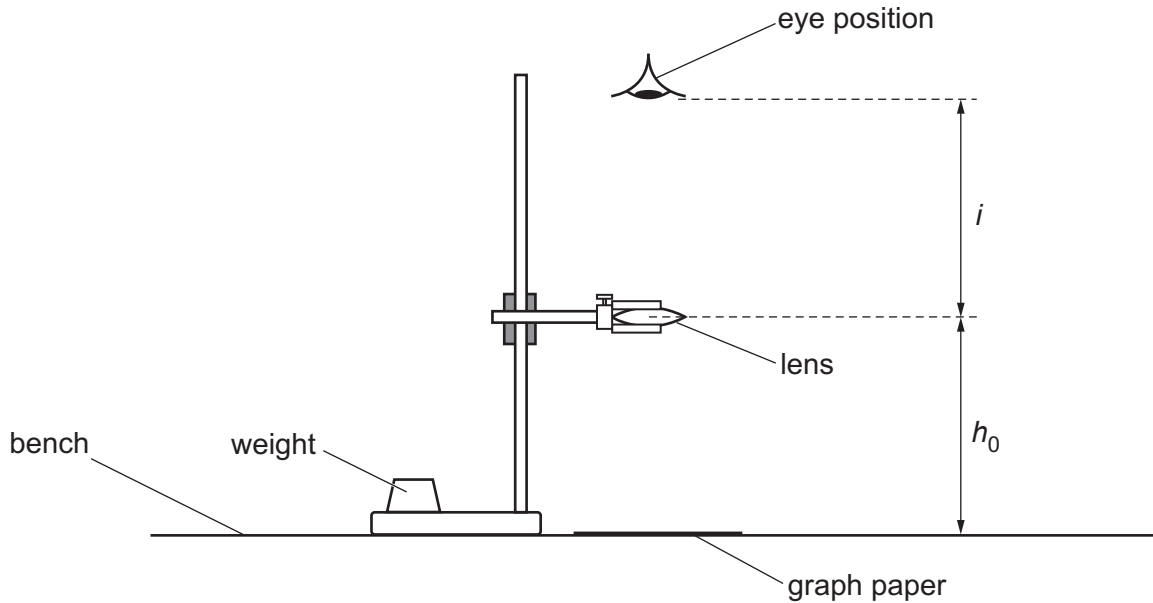

Fig. 3.1

(a) Measure and record, to the nearest mm, the height  $h_0$  of the lens above the graph paper.

$h_0 = \dots\dots\dots$  cm [1]

(b) Position your eye as far as you can above the lens.

Hold the graph paper just below the lens.

Observe the squares of the graph paper through the lens.

Now move the graph paper down until it reaches the bench.

Describe your observations.

.....

.....

..... [1]

- (c) With the graph paper on the bench, adjust the height of the lens on the stand until the lens is approximately 16 cm above the graph paper.

Position your eye at a distance  $i = 30$  cm above the lens and observe the squares of the graph paper through the lens.

- (i) Fig. 3.2 shows the graph paper. Fig. 3.3 shows the magnified image of the graph paper seen through the lens at one position.

Count and record the number of complete squares  $N$  observed across the horizontal diameter  $D$  of the lens shown in Fig. 3.3.

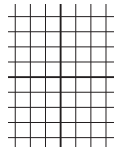

Fig. 3.2

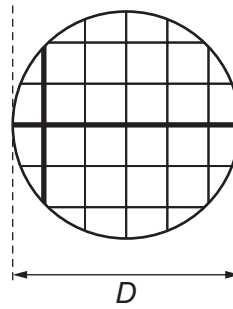

Fig. 3.3

number of complete squares  $N = \dots\dots\dots$  [1]

- (ii) Each small square of the graph paper has a side of length 2.0 mm.

Describe how to use  $D$  and  $N$  shown in (i) to estimate how much each square has been magnified by the lens.

.....  
 .....  
 ..... [1]

- (d) A student suggests that a more accurate value of the magnification produced by the lens is to repeat and average the measurements.

State **one other** way that the procedure could be improved in order to determine an accurate value of the magnification.

.....  
 ..... [1]

[Total: 5]

## Section B

4 In this experiment you will investigate the resistance of a light-emitting diode (LED).

You are provided with:

- a power supply
- a light-emitting diode
- 5 resistors of resistance  $150\ \Omega$
- a switch
- connecting wires and crocodile clips.

The supervisor has set up the circuit shown in Fig. 4.1.

The crocodile clip shown in the diagram in Fig. 4.1 is a movable contact that can be attached at different points in the circuit.

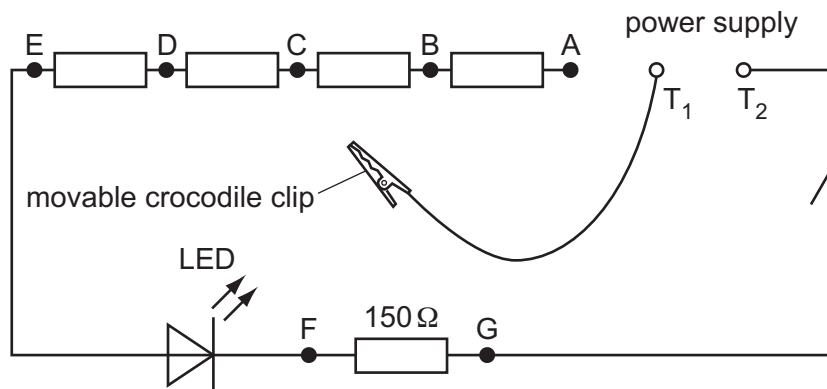

Fig. 4.1

You are also provided with a voltmeter and two additional connecting wires.

- (a) (i) Make sure that the movable crocodile clip and wire is not touching any other part of the circuit.

Connect the voltmeter between the terminals  $T_1$  and  $T_2$  of the power supply. Record the reading  $V_S$  on the voltmeter.

Disconnect the voltmeter from the power supply.

$$V_S = \dots\dots\dots \text{ V [1]}$$



- (ii) Attach the movable crocodile clip to one of the wires either side of the crocodile clip labelled A.

Connect the voltmeter between F and G.

Close the switch.

Record the reading  $V$  on the voltmeter.

Open the switch.

$$V = \dots\dots\dots V \quad [1]$$

- (iii) Using your answer from (a)(ii), calculate the current  $I_{\text{LED}}$  in the LED using the equation

$$I_{\text{LED}} = \frac{V}{150}.$$

$$I_{\text{LED}} = \dots\dots\dots A \quad [1]$$

- (iv) The total number of resistors connected in series with the LED is  $n$ . When the movable crocodile clip is attached by A, the value of  $n$  is 5.

Using your answers from (a)(i) and (a)(ii), calculate the voltage  $V_{\text{LED}}$  across the LED using the equation

$$V_{\text{LED}} = V_{\text{S}} - nV.$$

$$V_{\text{LED}} = \dots\dots\dots V \quad [1]$$

- (v) Using your answers from (a)(iii) and (a)(iv), calculate the resistance  $R_{\text{LED}}$  of the LED using the equation

$$R_{\text{LED}} = \frac{V_{\text{LED}}}{I_{\text{LED}}}.$$

$$R_{\text{LED}} = \dots\dots\dots \Omega \quad [1]$$

- (b) (i) In the appropriate row in Table 4.1, record your readings and calculations from (a)(ii), (iii), (iv) and (v).

Add appropriate headings with units to each column. [1]

- (ii) Repeat the procedure in (a)(ii) to (a)(v) with the movable crocodile clip connected by B, C, D and E.

Record your readings and calculations in Table 4.1.

**Table 4.1**

position of movable crocodile clip	$n$				
by A	5				
by B	4				
by C	3				
by D	2				
by E	1				

[3]

- (c) Using the grid on page 11, plot a graph of  $R_{LED}$  on the  $y$ -axis against  $I_{LED}$  on the  $x$ -axis.

Draw the curve of best fit. [4]

- (d) The values of the supply voltage and the resistance of the resistors have been carefully selected for use with this LED in this practical exercise.

Suggest **two** reasons why these values are suitable.

1. ....

.....

2. ....

.....

[2]

[Total: 15]

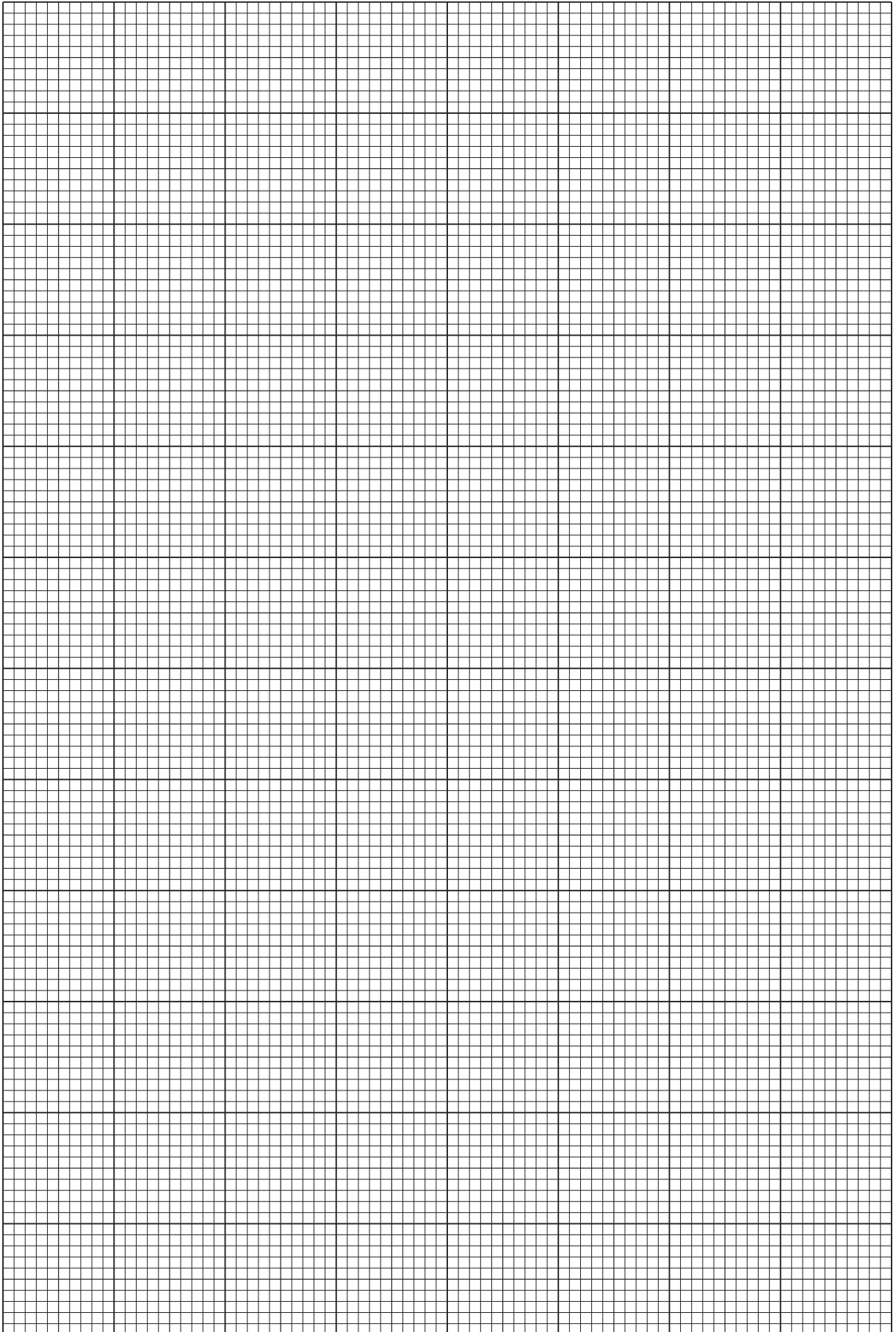

**BLANK PAGE**

---

Permission to reproduce items where third-party owned material protected by copyright is included has been sought and cleared where possible. Every reasonable effort has been made by the publisher (UCLES) to trace copyright holders, but if any items requiring clearance have unwittingly been included, the publisher will be pleased to make amends at the earliest possible opportunity.

To avoid the issue of disclosure of answer-related information to candidates, all copyright acknowledgements are reproduced online in the Cambridge Assessment International Education Copyright Acknowledgements Booklet. This is produced for each series of examinations and is freely available to download at [www.cambridgeinternational.org](http://www.cambridgeinternational.org) after the live examination series.

Cambridge Assessment International Education is part of Cambridge Assessment. Cambridge Assessment is the brand name of the University of Cambridge Local Examinations Syndicate (UCLES), which is a department of the University of Cambridge.