



Cambridge O Level

CANDIDATE NAME

CENTRE NUMBER

CANDIDATE NUMBER



PHYSICS **5054/31**
 Paper 3 Practical Test **October/November 2022**
2 hours

You must answer on the question paper.

You will need: The materials and apparatus listed in the confidential instructions

INSTRUCTIONS

- Answer **all** questions.
- Use a black or dark blue pen. You may use an HB pencil for any diagrams or graphs.
- Write your name, centre number and candidate number in the boxes at the top of the page.
- Write your answer to each question in the space provided.
- Do **not** use an erasable pen or correction fluid.
- Do **not** write on any bar codes.
- For each of the questions in Section A, you will be allowed to work with the apparatus for a maximum of 20 minutes. For the question in Section B, you will be allowed to work with the apparatus for a maximum of 1 hour.
- You should record all your observations in the spaces provided in the question paper as soon as these observations are made.
- You may use a calculator.
- You should show all your working and use appropriate units.

INFORMATION

- The total mark for this paper is 30.
- The number of marks for each question or part question is shown in brackets [].

For Examiner's Use	
1	
2	
3	
4	
Total	

This document has **12** pages. Any blank pages are indicated.

BLANK PAGE

Section A

Answer **all** the questions in this section.

1 In this experiment you will investigate the range of a magnetic field using a plotting compass.

You are provided with:

- a bar magnet
- a plotting compass
- a metre rule.

(a) Fig. 1.1 shows a plotting compass. The magnetic needle is mounted on a pivot so that it can rotate.

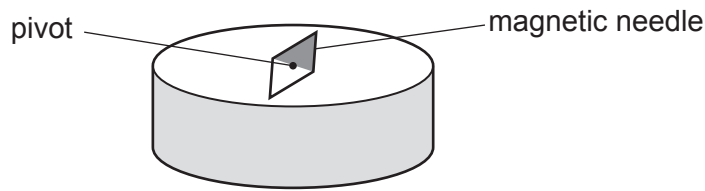

Fig. 1.1

Without removing the compass from the table, check that the magnetic needle is able to rotate freely.

Describe how you did this.

.....

.....

..... [2]

(b) Place the plotting compass over the 1 cm mark on the metre rule. Arrange the apparatus so that the scale markings on the rule point in the same direction as the needle as shown in Fig. 1.2.

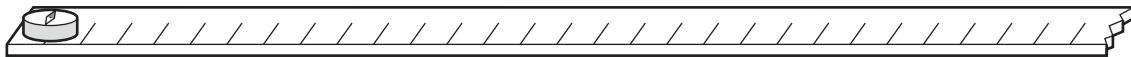

Fig. 1.2

Describe an experiment to find the maximum distance from the compass at which the bar magnet causes the magnetic needle to start to deflect.

.....

.....

.....

..... [3]

2 In this experiment you will investigate the temperature of water.

You are provided with:

- two boiling tubes in a rack
- two thermometers
- a stand, weight, boss and clamp
- a beaker to use to fill the boiling tubes with hot water
- stop-watch
- paper towel to mop up any spillages.

(a) Set up the apparatus as shown in Fig. 2.1.

Thermometer **A** is the thermometer in boiling tube A and thermometer **B** is the thermometer in boiling tube B.

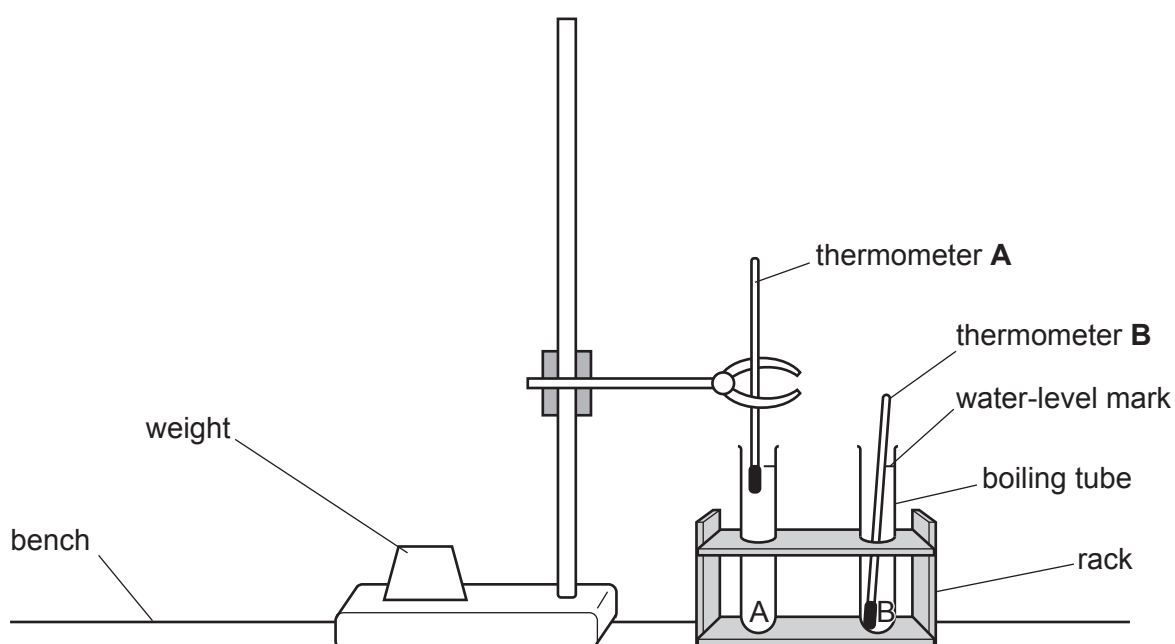

Fig. 2.1

Thermometer **A** must be held by the clamp and positioned so that the bulb of the thermometer is about 1 cm below the water-level mark on the side of the boiling tube.

Thermometer **B** must rest gently on the bottom of the boiling tube.

Measure and record the temperature:

T_A on thermometer **A**

$T_A = \dots\dots\dots$

T_B on thermometer **B**.

$T_B = \dots\dots\dots$

[2]

- (b) Do **not** change the position of the thermometers.
Ask the supervisor to fill your beaker with hot water.

Carefully pour hot water from the beaker into both boiling tubes until the water is level with the marked line on each tube.

Observe the temperature on the thermometers.

Measure and record the maximum temperature reached by each thermometer:

$T_{A (MAX)}$ on thermometer **A** $T_{A (MAX)} = \dots\dots\dots$

$T_{B (MAX)}$ on thermometer **B**. $T_{B (MAX)} = \dots\dots\dots$

Start the stop-watch and wait for 4 minutes.

Read and record the temperature on the thermometers after 4 minutes.

State which thermometer has shown the smaller temperature decrease from the maximum temperature.

temperature on thermometer **A** after 4 minutes =

temperature on thermometer **B** after 4 minutes =

thermometer which has the smaller temperature decrease = [1]

- (c) Suggest **two** reasons why one thermometer shows a smaller temperature decrease after 4 minutes.

1.
.....

2.
.....

[2]

[Total: 5]

3 In this experiment you will investigate the magnification produced by a lens.

You are provided with:

- a lens
- a mirror
- a stand, clamp and two bosses
- a rod
- a 30 cm ruler
- a metre rule.

The supervisor has set up the apparatus as shown in Fig. 3.1.

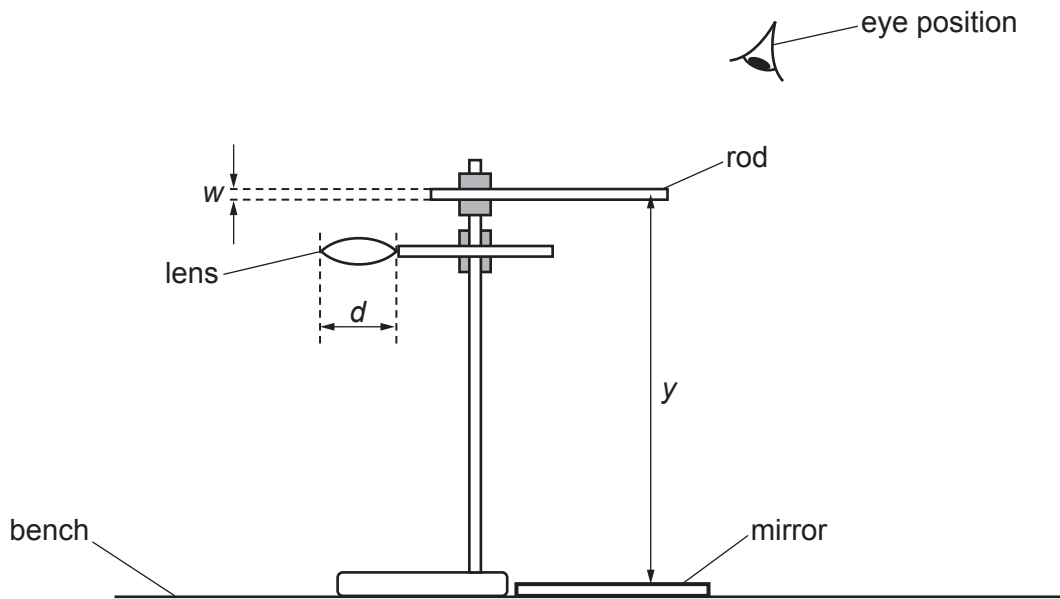

Fig. 3.1 (side view)

- (a) (i) Measure and record the diameter d of the lens and the width w of the rod to the nearest millimetre.

$d =$ mm

$w =$ mm
[1]

- (ii) Calculate the ratio r using the equation:

$$r = \frac{d}{w}$$

$r =$ [1]

- (b) Adjust the height of the rod on the stand so that the distance y from the centre of the rod to the mirror is 40.0 cm.

Rotate the clamp holding the lens around the clamp stand so that the lens is beside and just below the rod.

Look through the lens beside the rod. Ensure that the image of the rod formed in the mirror can be seen through the lens.

Move the lens slowly down towards the mirror. Observe that the image of the rod in the mirror seen through the lens becomes magnified.

Stop moving the lens when the width of the image of the rod is equal to the diameter of the lens. In this position, the ratio r calculated in (a)(ii) is equal to the magnification of the rod produced by the lens.

Measure and record the distance x between the rod and the lens.

$$x = \dots\dots\dots \text{ cm [1]}$$

- (c) A student says that the magnification m of the rod produced by the lens can also be calculated using the equation:

$$m = \frac{2y}{x} - 1$$

- (i) Calculate the value of m using the equation.

$$m = \dots\dots\dots [1]$$

- (ii) State if the values of r and m can be considered to be the same.

Give a reason for your answer.

.....

..... [1]

[Total: 5]

Section B

4 In this experiment you will find the resistance of a length of wire.

You are provided with:

- a power supply with voltage V_S
- a card with the voltage of the power supply V_S recorded on it.
- a resistor X
- a length of resistance wire attached to a metre rule
- a switch
- voltmeter
- connecting leads with crocodile clips.

The supervisor has set up the circuit as shown in Fig. 4.1 using the supplied apparatus.

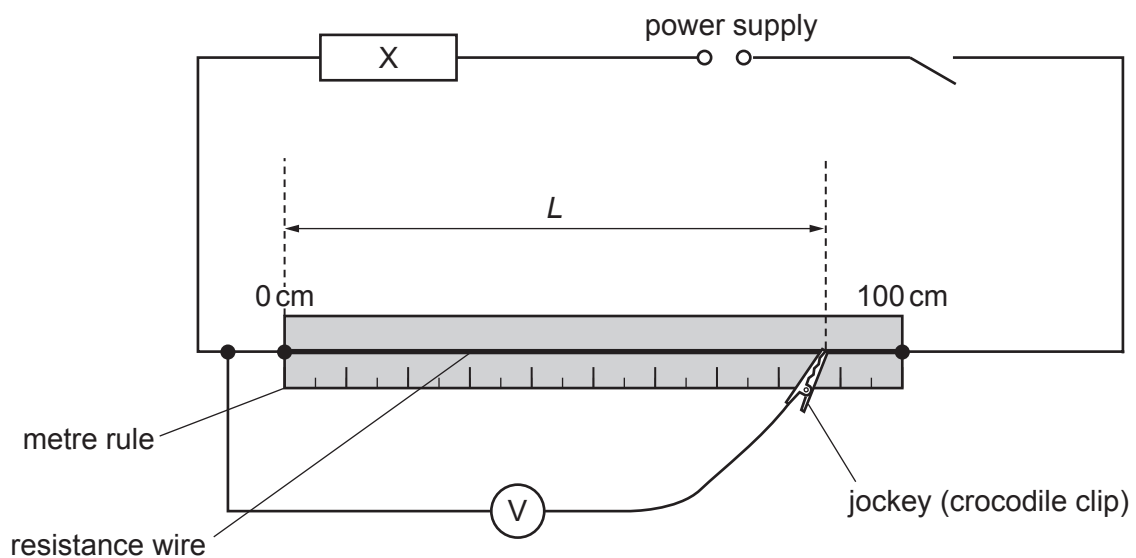

Fig. 4.1

The crocodile clip labelled in Fig. 4.1 acts as a jockey that can make contact with the resistance wire by sliding along the wire or by being clipped to it.

(a) State whether the voltmeter is analogue or digital. Tick **one** box.

analogue

digital

State the range and precision of the voltmeter.

range:

precision:

[2]

(b) Close the switch.

Length L is the distance along the ruler from the 0 cm mark.

Clip the jockey on to the resistance wire at a length $L = 100.0$ cm from the 0 cm end of the metre rule.

V_S is the voltage of the power supply written on the card.

V_L is the reading on the voltmeter with the jockey clipped at length L .

Record V_S and V_L .

$V_S =$ V

$V_L =$ V

[1]

(c) There is a reading on the voltmeter when the jockey just touches the resistance wire as well as when it is clipped to the resistance wire.

Explain why it is important to clip the jockey to the resistance wire when taking and recording the voltage.

.....

..... [1]

(d) In Table 4.1, record the value of V_L at 100.0 cm from (b).

For a range of different lengths L in cm of the resistance wire, measure and record the new values of V_L . Record all of your results in Table 4.1.

Add appropriate headings with units to each column.

Table 4.1

[4]

(e) Plot a graph of V_L in V on the y-axis against L in cm on the x-axis on the graph grid on page 11.

Draw the straight line of best fit through your points. [4]

(f) Determine the gradient G of the line of best fit.

Show your working and indicate on the graph the values you use to calculate the gradient G .

$G =$ [2]

Question 4 continues on page 12.

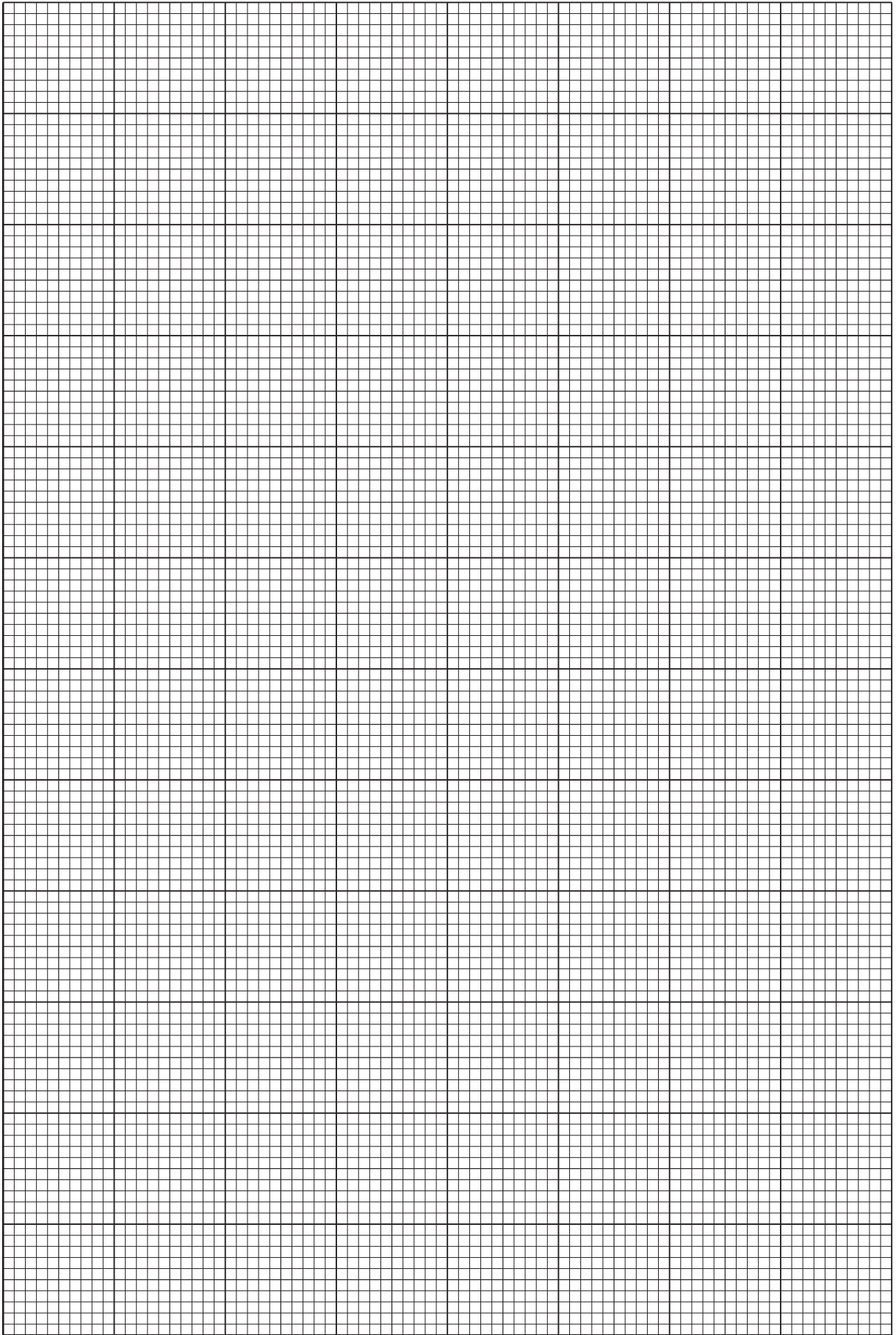

(g) The resistance R_w of the wire is calculated using the equation:

$$R_w = \frac{22}{N}$$

where $N = \frac{V_S}{100G} - 1$.

Use your value of V_S recorded in (b) and your value of G calculated in (f) to calculate R_w .

Show your working.

$$R_w = \dots\dots\dots \Omega \quad [1]$$

[Total: 15]

Permission to reproduce items where third-party owned material protected by copyright is included has been sought and cleared where possible. Every reasonable effort has been made by the publisher (UCLES) to trace copyright holders, but if any items requiring clearance have unwittingly been included, the publisher will be pleased to make amends at the earliest possible opportunity.

To avoid the issue of disclosure of answer-related information to candidates, all copyright acknowledgements are reproduced online in the Cambridge Assessment International Education Copyright Acknowledgements Booklet. This is produced for each series of examinations and is freely available to download at www.cambridgeinternational.org after the live examination series.

Cambridge Assessment International Education is part of Cambridge Assessment. Cambridge Assessment is the brand name of the University of Cambridge Local Examinations Syndicate (UCLES), which is a department of the University of Cambridge.