



# Cambridge O Level

CANDIDATE  
NAME

--

CENTRE  
NUMBER

--	--	--	--	--

CANDIDATE  
NUMBER

--	--	--	--



**PHYSICS**

**5054/22**

Paper 2 Theory

**October/November 2022**

**1 hour 45 minutes**

You must answer on the question paper.

No additional materials are needed.

## INSTRUCTIONS

- Section A: answer **all** questions.
- Section B: answer **two** questions.
- Use a black or dark blue pen. You may use an HB pencil for any diagrams or graphs.
- Write your name, centre number and candidate number in the boxes at the top of the page.
- Write your answer to each question in the space provided.
- Do **not** use an erasable pen or correction fluid.
- Do **not** write on any bar codes.
- You may use a calculator.
- You should show all your working and use appropriate units.

## INFORMATION

- The total mark for this paper is 75.
- The number of marks for each question or part question is shown in brackets [ ].

This document has **20** pages. Any blank pages are indicated.

**Section A**

Answer **all** questions in this section. Answer in the spaces provided.

- 1 A train travels along a straight horizontal track. At time  $t = 0$ , the train passes through station P at constant speed without stopping.

The driver applies the brakes 70 s before reaching station Q. The train decelerates.

Fig. 1.1 is the speed–time graph for the train from  $t = 0$  until it stops at station Q.

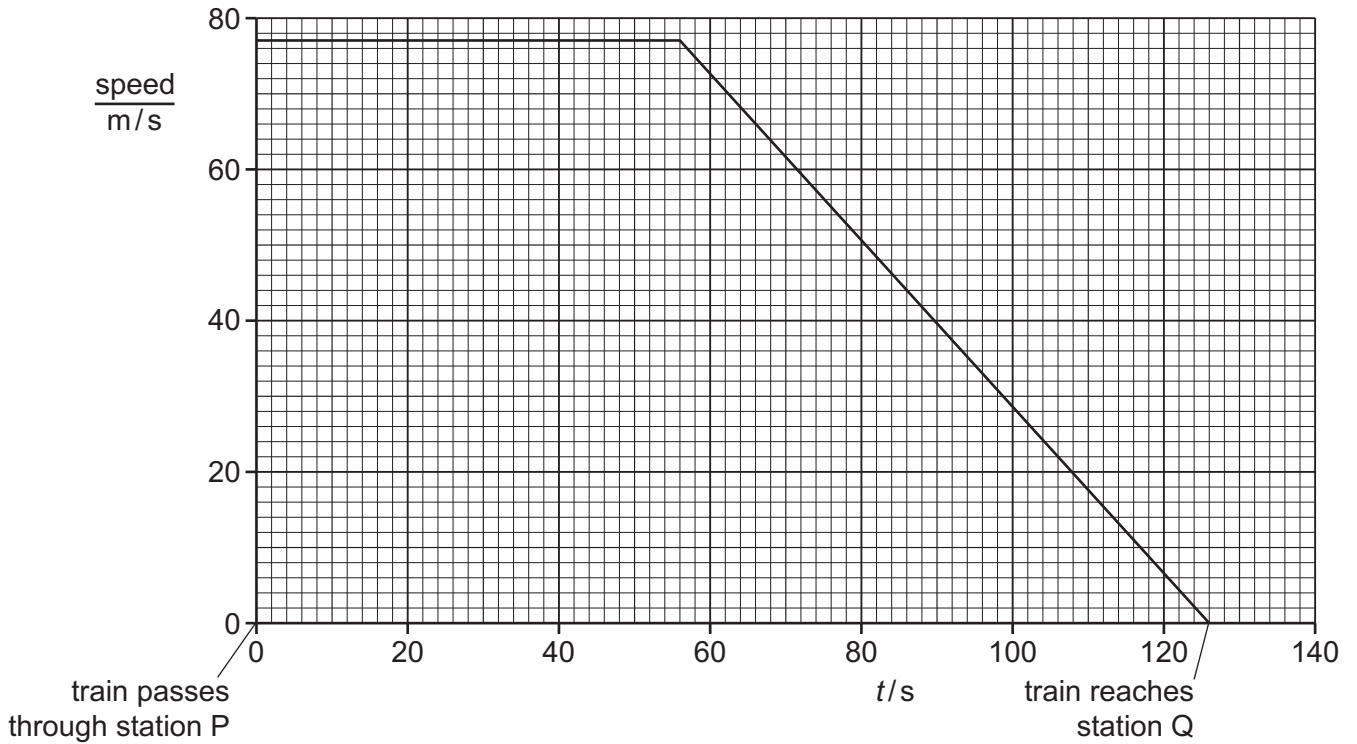

**Fig. 1.1**

- (a) Using Fig. 1.1, determine the distance between station P and station Q.

distance = ..... [3]

(b) The mass of the train is  $3.8 \times 10^5$  kg.

(i) Determine the deceleration of the train in the 70 s before it stops at station Q.

deceleration = ..... [2]

(ii) Calculate the resultant force on the train as it decelerates.

resultant force = ..... [2]

[Total: 7]

- 2 The foundations that support a building are long concrete cylinders that are pointed at one end. A pile-driver is a machine that forces the pointed concrete cylinders into the ground.

Fig. 2.1 shows a pile-driver.

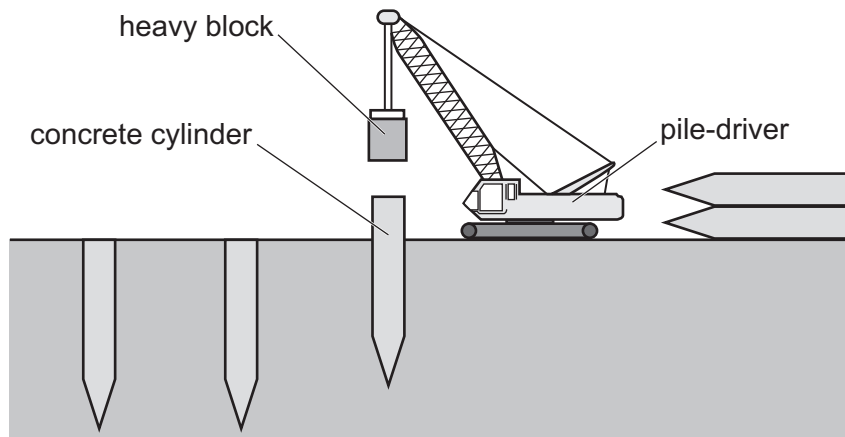

**Fig. 2.1**

A heavy block of mass  $2.9 \times 10^4$  kg is lifted into the air then dropped onto the top of a concrete cylinder. This forces the cylinder into the ground.

- (a) Fig. 2.2 shows the heavy block.

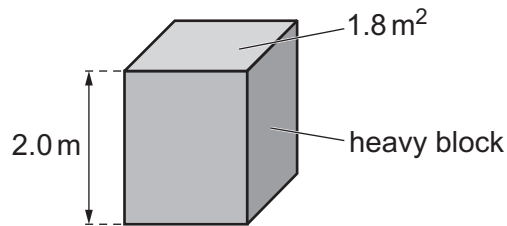

**Fig. 2.2**

The block is 2.0 m tall and has a cross-sectional area of  $1.8 \text{ m}^2$ .

Calculate the density of the material used to make the block.

density = ..... [2]

(b) The pile-driver lifts the block from the top of a concrete cylinder, through a height of 0.80 m.

The gravitational field strength  $g$  is 10 N/kg.

(i) Calculate the gravitational potential energy gained by the block.

gravitational potential energy = ..... [2]

(ii) The block is then dropped from rest onto the top of the concrete cylinder.

Calculate the speed of the block just before it hits the concrete cylinder.

speed = ..... [3]

[Total: 7]

3 Fig. 3.1 shows a man standing underneath an outdoor heater on a cold evening.

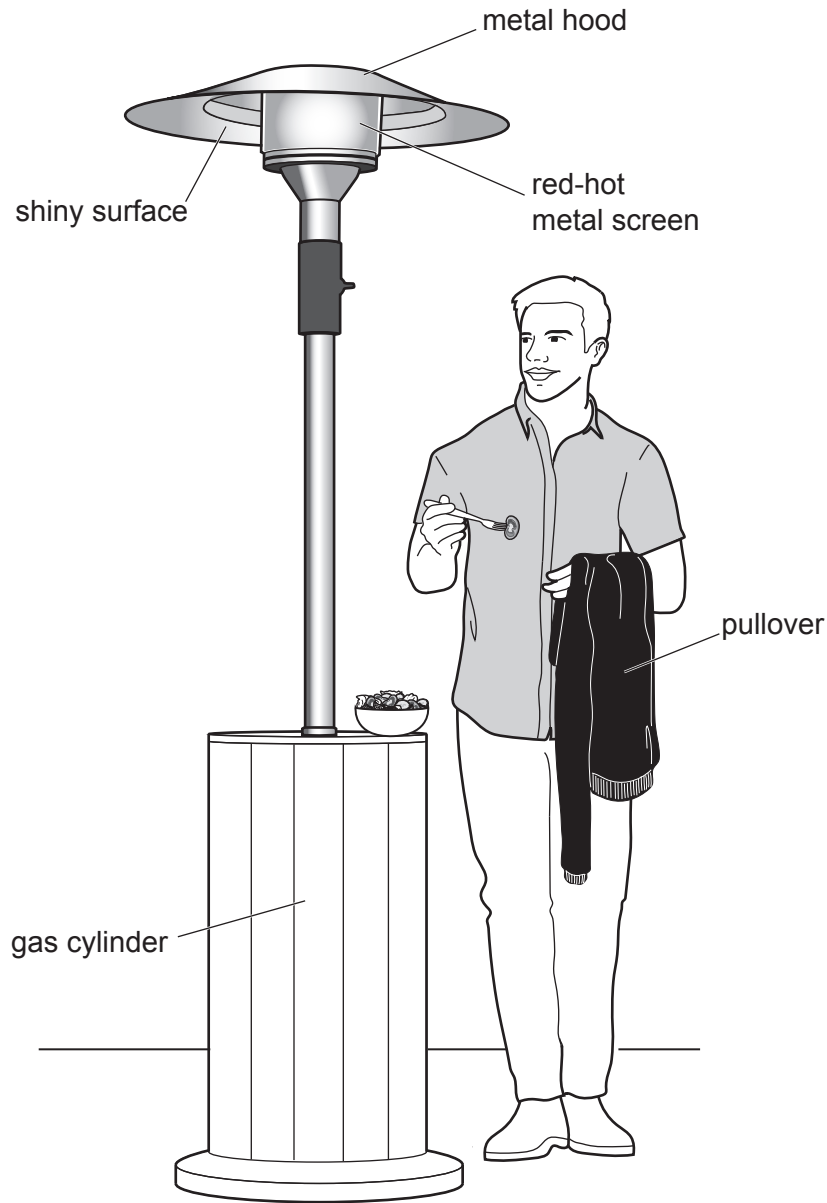

Fig. 3.1

Gas in the cylinder at the base of the heater is the fuel for the heater. When the heater is operating, the gas travels to the top of the heater where it burns.

(a) State the form of energy stored in the gas that is transferred by the heater.

..... [1]

(b) A metal screen surrounding the burning gas is heated by the burning gas until it is red-hot. The hot metal screen warms the man who is standing underneath it.

(i) Describe how thermal energy in the red-hot metal screen is transferred to the man and how it warms him.

.....  
.....  
.....  
.....  
..... [3]

(ii) At the top of the heater is a metal hood that has a shiny lower surface.

Explain why this makes the energy transfer from the metal screen more efficient.

.....  
.....  
..... [2]

(iii) The air temperature decreases and the man puts on a black pullover.

Explain **one** way in which wearing the black pullover helps to keep the man warm.

.....  
.....  
..... [2]

[Total: 8]

4 A sound wave, travelling in air or water, contains compressions and rarefactions.

(a) Describe an experiment to show that a medium is required to transmit sound waves. You may draw a labelled diagram if you wish.

.....  
.....  
.....  
.....  
..... [3]

(b) When a sound wave passes through air or water, the molecules of the air or water move.

Describe the motion of the molecules due to the sound wave.

.....  
.....  
..... [2]

(c) Describe what is meant by 'a rarefaction'.

.....  
..... [1]



(d) Fig. 4.1 shows a dolphin.

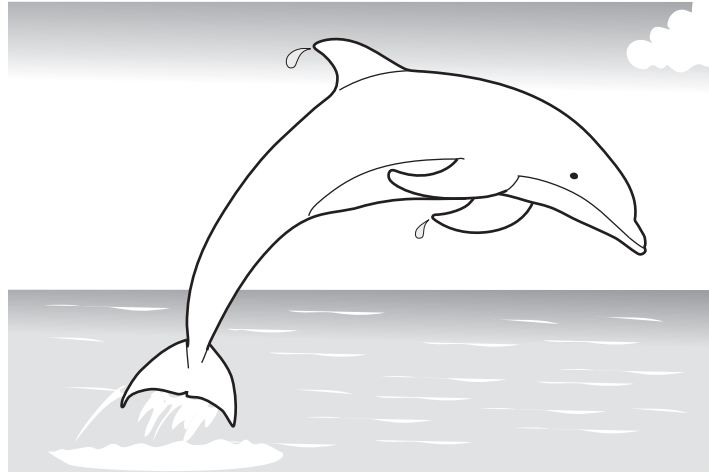

**Fig. 4.1**

The range of audible sound frequencies for the dolphin is 75 Hz to 140 000 Hz.

In water, the speed of sound is 1500 m/s.

Calculate the smallest wavelength of sound in water that the dolphin can hear.

wavelength = ..... [2]

[Total: 8]

5 The power supply in a circuit is made from several cells, each with the same electromotive force (e.m.f.). The cells are connected in parallel.

(a) Explain what is meant by 'electromotive force'.

.....  
.....  
..... [2]

(b) State **one** advantage of using several cells in parallel rather than a single cell as the power supply.

.....  
..... [1]

(c) The power supply is connected in series to a resistor of resistance  $4000\Omega$  and a thermistor. There is a voltmeter in parallel with the resistor.

Fig. 5.1 is the circuit diagram.

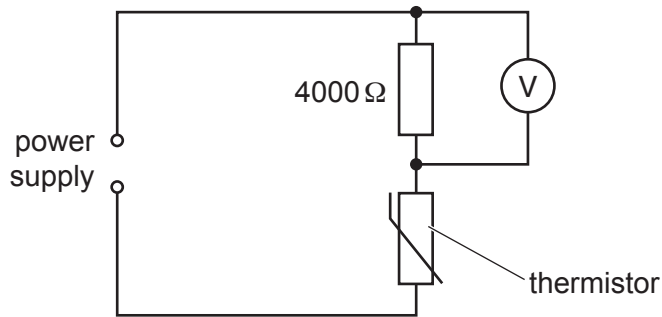

Fig. 5.1

(i) The temperature of the thermistor increases.

Explain what happens to the reading on the voltmeter.

.....  
.....  
..... [3]

(ii) The e.m.f. of the power supply is 1.5V.

Calculate the reading on the voltmeter when the resistance of the thermistor is  $8000\Omega$ .

reading = ..... [2]

[Total: 8]

- 6 The primary coil of a transformer is connected to the mains supply. The voltage of the a.c. mains supply is 240V.

Fig. 6.1 is a diagram of the arrangement.

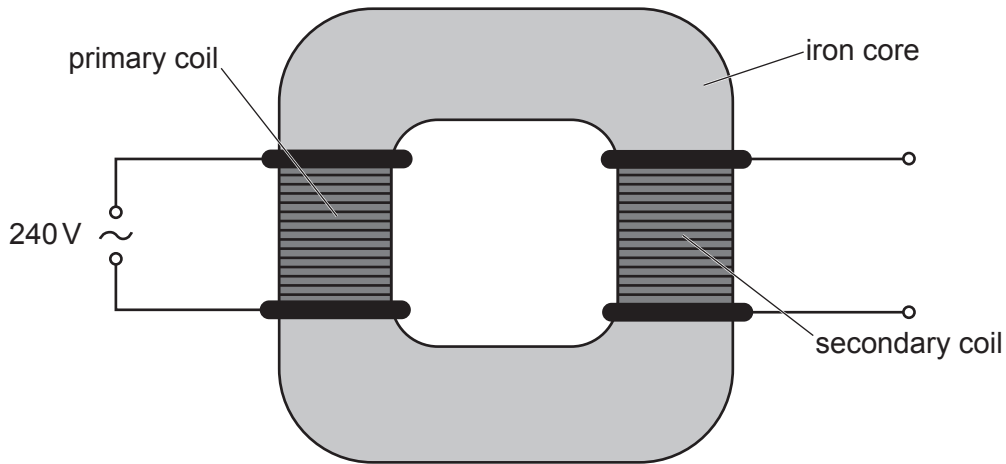

Fig. 6.1

- (a) Explain why a voltage is produced in the secondary coil.

.....  
 .....  
 ..... [3]

- (b) There are 5600 turns on the primary coil of the transformer and 350 turns on the secondary coil.

- (i) Calculate the output voltage of the transformer.

output voltage = ..... [2]

- (ii) The output of the transformer is connected to a 90W filament lamp which operates at normal brightness.

Calculate the current in the lamp.

current = ..... [2]

[Total: 7]

**[Turn over**

**Section B**

Answer **two** questions from this section. Answer in the spaces provided.

7 Copper is sometimes chosen as a material to make pans for heating liquids.

A copper pan contains water at room temperature.

(a) The top surface of the water in the pan cools as water evaporates. A convection current causes the rest of the water to cool.

Explain how this convection current is produced.

.....  
.....  
.....  
.....  
..... [3]

(b) The copper pan is now placed on a hotplate that is switched on.

(i) Name the process by which thermal energy passes through the base of the pan.

..... [1]

(ii) Copper remains a solid when heated up to 1000 °C.

State **one** other reason why it is sensible to make a pan out of copper.

..... [1]

(c) The water in the pan is heated from 17 °C until it starts to boil at 100 °C.

(i) The specific heat capacity of water is 4200 J/(kg °C) and the pan contains 750 g of water.

Calculate the energy needed to increase the temperature of the water from 17 °C to 100 °C.

energy = ..... [3]

(ii) State **two** ways in which boiling differs from evaporation.

1 .....

.....

2 .....

.....

[2]

(iii) At 100 °C the temperature of the water stops increasing, even though energy is still being transferred to the water.

Explain, in terms of molecules, why thermal energy is needed to change the state of the water from liquid to gas.

.....

.....

.....

.....

[2]

(iv) The specific latent heat of vaporisation of water is  $2.3 \times 10^6 \text{ J/kg}$ .

Thermal energy is transferred to the boiling water at a rate of 1300 J/s.

Calculate the mass of water that boils away in the 10 minutes immediately after the water reaches 100 °C.

mass = ..... [3]

[Total: 15]

8 An uncharged plastic rod is rubbed with an uncharged woollen cloth.

As a result, the rod becomes negatively charged.

(a) Explain, in terms of particles, how the rod becomes charged and state what happens to the cloth.

.....  
.....  
.....  
..... [2]

(b) Fig. 8.1 shows a metal sphere X on a plastic stand.

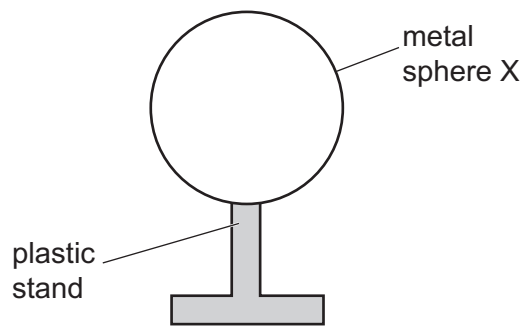

Fig. 8.1

Explain why metals are electrical conductors and why plastics are electrical insulators.

.....  
.....  
.....  
..... [2]

(c) The negatively charged plastic rod is held above sphere X.

Fig. 8.2 shows that it does not touch the sphere.

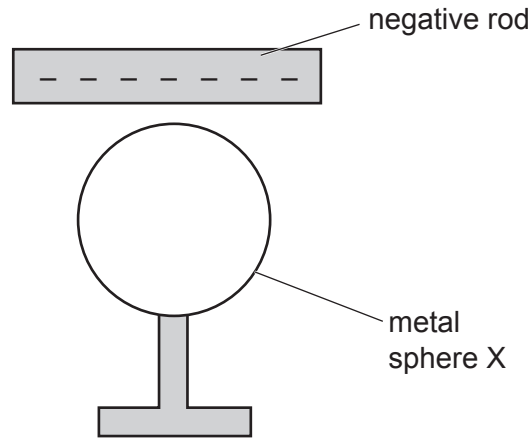

Fig. 8.2

- (i) By drawing on Fig. 8.2, show the distribution of charge on X. [2]
- (ii) An earth wire is now connected to the metal sphere as shown in Fig. 8.3.

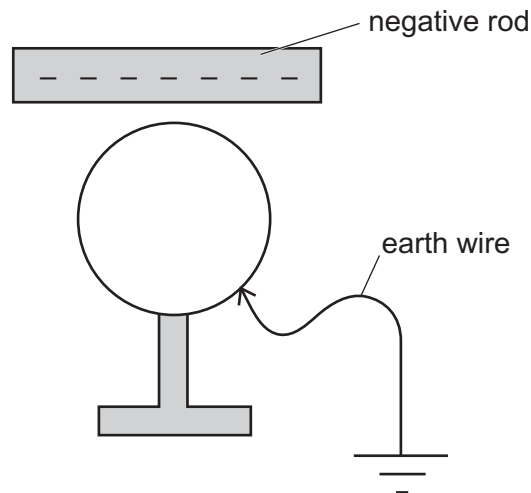

Fig. 8.3

State what happens to the charges on the sphere as the earth wire is connected.

.....  
..... [1]

(iii) The earth wire in (ii) stays connected to the metal sphere.

Describe the distribution of charge on the sphere.

.....  
.....  
..... [2]

(iv) The earth wire is disconnected from the sphere and then the negatively charged rod is moved away from the sphere.

Explain what happens to the charges on the sphere as the charged rod is moved away.

.....  
.....  
..... [2]

(d) A second metal sphere Y is negatively charged.

There is an electric field surrounding Y.

(i) State what is meant by 'electric field'.

.....  
..... [1]

(ii) Fig. 8.4 shows the negatively charged sphere Y. The negative charges are not shown.



**Fig. 8.4**

On Fig. 8.4, draw the pattern and mark the direction of the electric field lines surrounding sphere Y. [3]

[Total: 15]



9 Protactinium-234 ( ${}_{91}^{234}\text{Pa}$ ) is a radioactive isotope of protactinium that decays to uranium-234 ( ${}_{92}^{234}\text{U}$ ).

(a) Compare the nuclide notation  ${}_{91}^{234}\text{Pa}$  with the nuclide notation  ${}_{92}^{234}\text{U}$  and deduce what this shows about what is emitted from a nucleus of protactinium-234 as it decays to uranium-234.

Place a tick (✓) in the appropriate boxes of Table 9.1 to show what is deduced from comparing the nuclide notations.

Table 9.1

	yes	no	it is not possible to tell
an alpha-particle is emitted			
a beta-particle is emitted			
a gamma ray is emitted			

[2]

(b) The most abundant isotope of protactinium is protactinium-231.

(i) Explain, by referring to their nuclear compositions, why protactinium-231 and protactinium-234 are both isotopes of the same element.

.....  
 ..... [1]

(ii) Explain, by referring to their nuclear compositions, why protactinium-231 and protactinium-234 are different isotopes of that element.

.....  
 ..... [1]

(c) A teacher places a radiation detector on a bench in a school laboratory and switches it on.

(i) The teacher measures and records the background radiation count rate.

Describe what is meant by 'background radiation' and state **two** significant sources of the count rate recorded by the teacher.

background radiation .....

.....

source 1 .....

source 2 .....

[3]

- (ii) The teacher moves a sample of protactinium-234 so that it is next to the detector.

Suggest **one** precaution that ensures that the sample is moved in a safe way.

.....  
 ..... [1]

- (iii) The count rate is measured every 20s with the sample present, and then corrected for background radiation.

Fig. 9.1 shows a graph of the corrected count rate against time for the protactinium-234 sample.

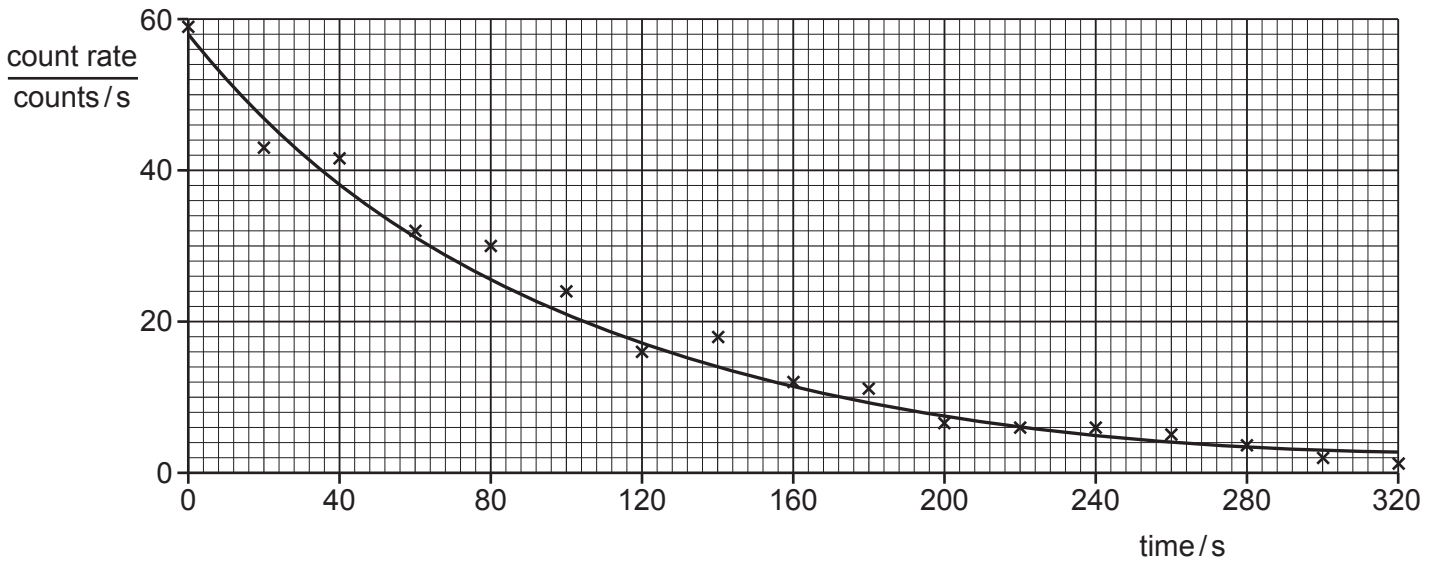

Fig. 9.1

The curve is the best-fit line.

Explain why many of the crosses do not lie on the curve.

.....  
 .....  
 ..... [2]

(iv) Using Fig. 9.1, determine the half-life of protactinium-234.

Show your working.

half-life = ..... [3]

(v) The uranium-234 formed from the protactinium-234 is also radioactive. Its half-life is many thousands of years.

Explain why the radiation from uranium-234 does **not** affect the count rates measured in this experiment.

.....  
.....  
..... [2]

[Total: 15]

**BLANK PAGE**

---

Permission to reproduce items where third-party owned material protected by copyright is included has been sought and cleared where possible. Every reasonable effort has been made by the publisher (UCLES) to trace copyright holders, but if any items requiring clearance have unwittingly been included, the publisher will be pleased to make amends at the earliest possible opportunity.

To avoid the issue of disclosure of answer-related information to candidates, all copyright acknowledgements are reproduced online in the Cambridge Assessment International Education Copyright Acknowledgements Booklet. This is produced for each series of examinations and is freely available to download at [www.cambridgeinternational.org](http://www.cambridgeinternational.org) after the live examination series.

Cambridge Assessment International Education is part of Cambridge Assessment. Cambridge Assessment is the brand name of the University of Cambridge Local Examinations Syndicate (UCLES), which is a department of the University of Cambridge.