



**Cambridge International Examinations**  
Cambridge Ordinary Level

CANDIDATE NAME

CENTRE NUMBER

CANDIDATE NUMBER



**PHYSICS**

**5054/41**

Paper 4 Alternative to Practical

**May/June 2015**

**1 hour**

Candidates answer on the Question Paper.

No Additional Materials are required.

**READ THESE INSTRUCTIONS FIRST**

Write your Centre number, candidate number and name on all the work you hand in.

Write in dark blue or black pen.

You may use an HB pencil for any diagrams or graphs.

Do not use staples, paper clips, glue or correction fluid.

**DO NOT WRITE IN ANY BARCODES.**

Answer **all** questions.

Electronic calculators may be used.

You may lose marks if you do not show your working or if you do not use appropriate units.

At the end of the examination, fasten all your work securely together.

The number of marks is given in brackets [ ] at the end of each question or part question.

This document consists of **8** printed pages.

1 A student investigates a ball bouncing on a bench.

(a) The student drops the ball from a height  $H$  of 100 cm above the bench, as shown in Fig. 1.1a. He measures the height  $h$  of the ball at the top of the first bounce. The motion of the ball is shown in Fig. 1.1a, b and c.

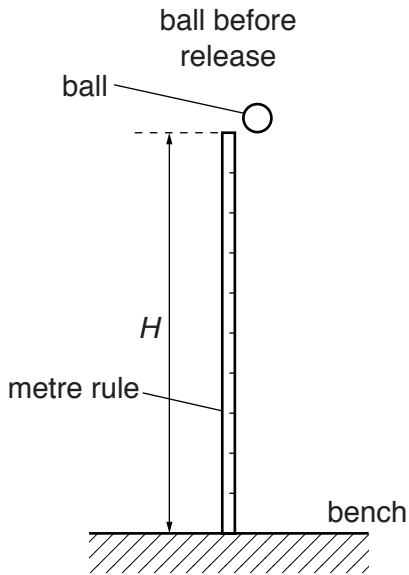

Fig. 1.1a

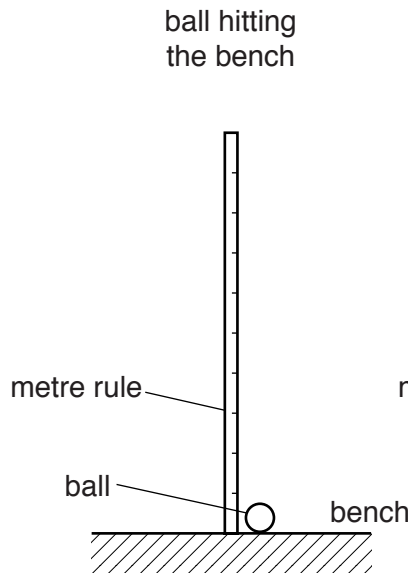

Fig. 1.1b

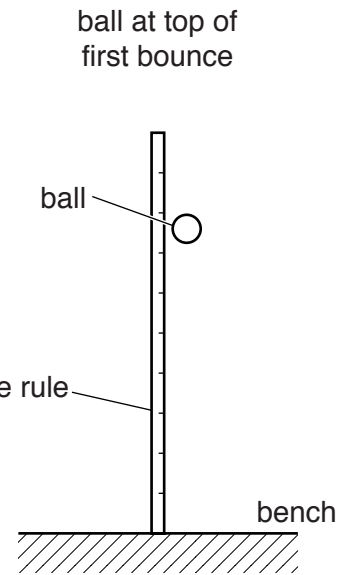

Fig. 1.1c

(i) State how the student can check that the metre rule is vertical.

.....  
 ..... [1]

(ii) State and explain which part of the ball the student should use when measuring  $h$ .

.....  
 ..... [1]

(iii) On Fig. 1.1c, mark and label  $h$ . [1]

(iv) On Fig. 1.1c, draw the position of the student's eye when measuring  $h$ . [1]

(v) Suggest two reasons why it is difficult for the student to measure  $h$  accurately.

1. ....  
 .....  
 2. ....  
 .....

[2]

- (b) The student repeats the experiment for different values of  $H$ . For each value of  $H$ , he takes three readings for  $h$ . He records his results in Fig. 1.2.

$H/cm$	$h/cm$			$h_{av}/cm$
100	64	67	69	
90	58	61	62	
80	52	54	56	
60	40	42	39	
40	27	25	28	
20	14	12	14	

Fig. 1.2

- (i) For each value of  $H$ , the average value of  $h$  is  $h_{av}$ . Complete Fig. 1.2, giving your values of  $h_{av}$  to 3 significant figures. [1]
- (ii) On Fig. 1.3, plot a graph of  $h_{av}/cm$  on the  $y$ -axis against  $H/cm$  on the  $x$ -axis. Start your axes from (0,10). Draw the straight line of best fit.

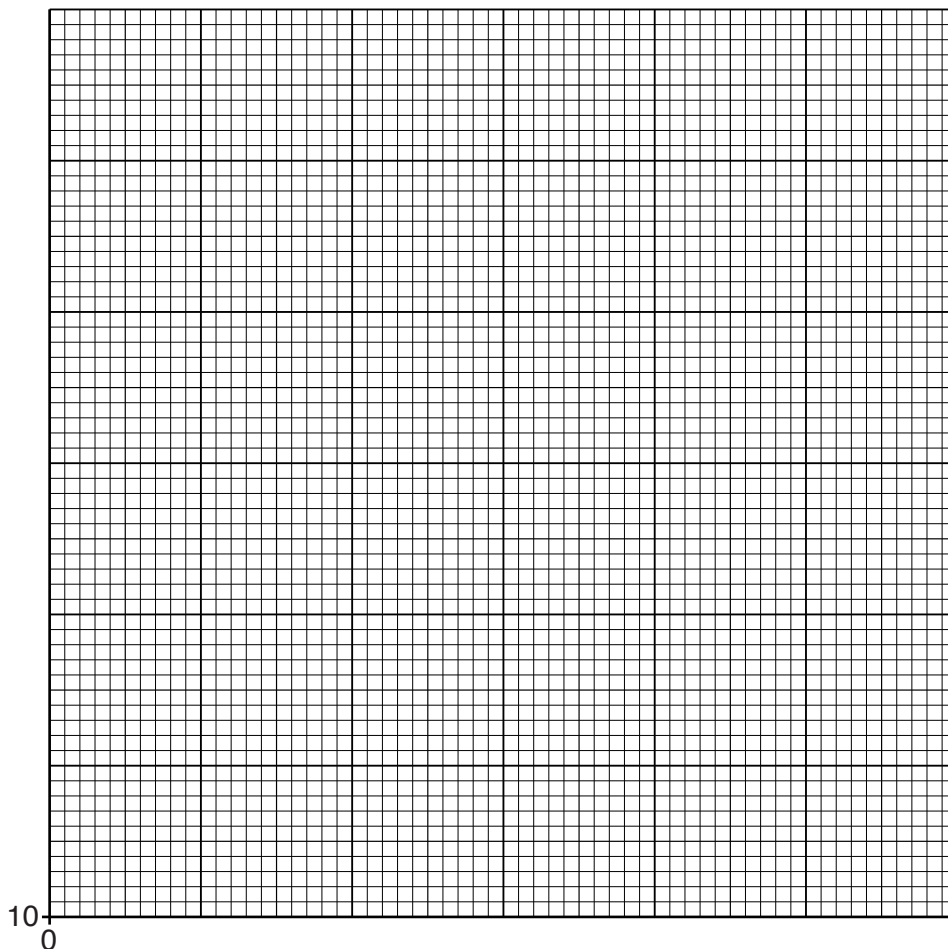

Fig. 1.3

[4]

(iii) The quantity  $e$  is given by

$$e = \frac{\sqrt{h_{av}}}{\sqrt{H}}.$$

Theory shows that  $e$  is constant.

Using two points from the graph, calculate two values of  $e$ .  
Comment on whether  $e$  is constant for the student's results.

.....  
.....[2]

2 A rain-gauge is used to measure the amount of rain that falls.

Fig. 2.1 shows a typical rain-gauge.

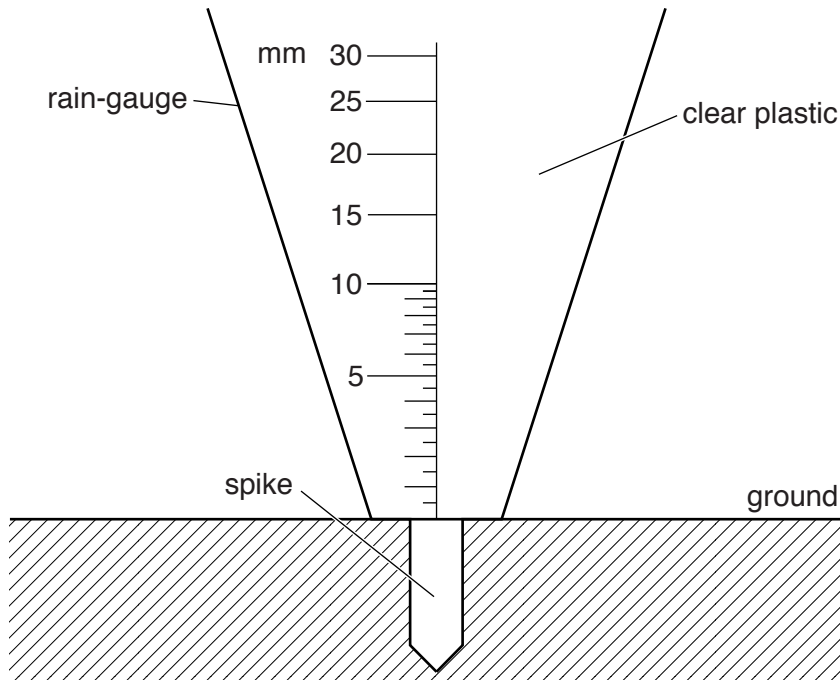

Fig. 2.1

(a) (i) The shape of the rain-gauge causes the scale to be non-linear. With reference to Fig. 2.1, explain what is meant by a *non-linear scale*.

.....  
 ..... [1]

(ii) Suggest why this non-linear scale is useful in a rain-gauge.

.....  
 ..... [1]

(b) On one day, the rain-gauge measures 7.5 mm of rain.

(i) On Fig. 2.1, show the level of water in the rain-gauge. [1]

(ii) A student picks up the rain-gauge to read it. Suggest one possible source of error this causes in reading the rain-gauge.

..... [1]

(c) Suggest a reason why the rain-gauge

(i) is made from a transparent material,  
 ..... [1]

(ii) has a spike.  
 ..... [1]



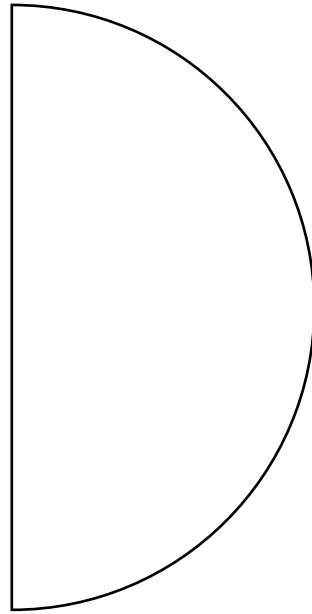

**Fig. 3.1**

4 A student measures the time for which a 1.5 V cell can provide a steady current of 0.3 A.

(a) The student sets up a circuit including the cell. She measures the current produced by the cell and varies the resistance of the circuit to keep the current constant.

(i) In the space below, draw the circuit she uses.

[2]

(ii) Name the equipment the student uses to

- 1. measure the current, .....
- 2. vary the resistance, .....
- 3. measure the time. ....

[1]

(iii) The student chooses from three analogue meters to measure the current. The meters have ranges 0 to 10 A, 0 to 1 A and 0 to 0.1 A.

Explain why the 0 to 1 A meter is the most suitable.

.....  
.....[1]

(iv) Describe how the student adjusts the circuit to keep the current constant.

.....  
.....[1]

(b) A second student repeats the experiment using a much larger current. Suggest one hazard this may cause.

.....  
.....[1]

Permission to reproduce items where third-party owned material protected by copyright is included has been sought and cleared where possible. Every reasonable effort has been made by the publisher (UCLES) to trace copyright holders, but if any items requiring clearance have unwittingly been included, the publisher will be pleased to make amends at the earliest possible opportunity.

To avoid the issue of disclosure of answer-related information to candidates, all copyright acknowledgements are reproduced online in the Cambridge International Examinations Copyright Acknowledgements Booklet. This is produced for each series of examinations and is freely available to download at www.cie.org.uk after the live examination series.

Cambridge International Examinations is part of the Cambridge Assessment Group. Cambridge Assessment is the brand name of University of Cambridge Local Examinations Syndicate (UCLES), which is itself a department of the University of Cambridge.