



Cambridge  
**O Level**

**Cambridge International Examinations**  
Cambridge Ordinary Level

CANDIDATE  
NAME

--

CENTRE  
NUMBER

--	--	--	--	--

CANDIDATE  
NUMBER

--	--	--	--



**PHYSICS**

**5054/21**

Paper 2 Theory

**May/June 2015**

**1 hour 45 minutes**

Candidates answer on the Question Paper.

No Additional Materials are required.

**READ THESE INSTRUCTIONS FIRST**

Write your Centre number, candidate number and name on all the work you hand in.

Write in dark blue or black pen.

You may use an HB pencil for any diagrams or graphs.

Do not use staples, paper clips, glue or correction fluid.

**DO NOT WRITE IN ANY BARCODES.**

**Section A**

Answer **all** questions.

Write your answers in the spaces provided on the Question Paper.

**Section B**

Answer any **two** questions.

Write your answers in the spaces provided on the Question Paper.

Electronic calculators may be used.

You may lose marks if you do not show your working or if you do not use appropriate units.

At the end of the examination, fasten all your work securely together.

The number of marks is given in brackets [ ] at the end of each question or part question.

This document consists of **20** printed pages.

**Section A**

Answer **all** the questions in this section. Answer in the spaces provided.

- 1 Fig. 1.1 shows the distance-time graph for two cyclists A and B. They start a 500 m race together but finish the race at different times.

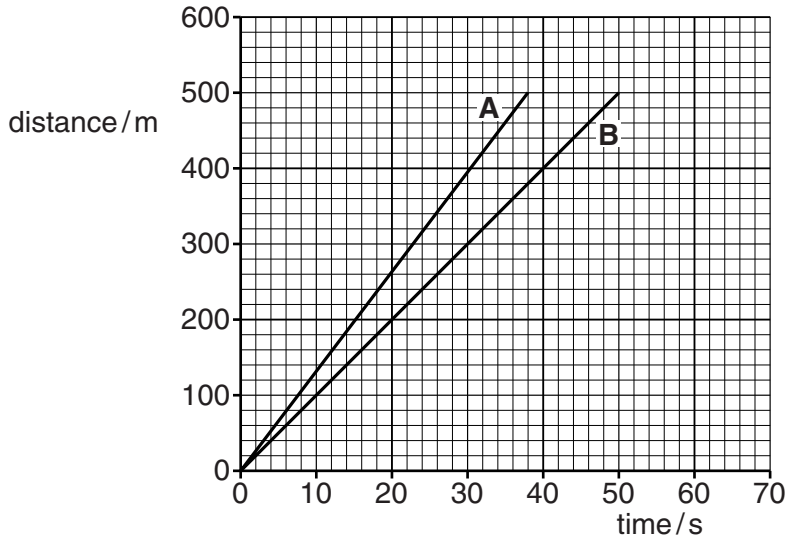

**Fig. 1.1**

(a) Use Fig. 1.1 to determine

- (i) the distance between A and B at time  $t = 20$  s,

.....[1]

- (ii) the difference in the time taken by A and B for the race.

.....[1]

(b) Cyclist C starts the race at the same time as A and B and covers the first 200 m of the race at a constant speed of 5.0 m/s. He then accelerates and finishes the race at  $t = 60$  s.

- (i) On Fig. 1.1, draw the distance-time graph for cyclist C. [2]

- (ii) Calculate the average speed of cyclist C for the whole race.

speed = .....[2]

- 2 Fig. 2.1 shows a student doing a press-up. A total force  $F$  acts upwards on his hands. There is also a force upwards on his toes.

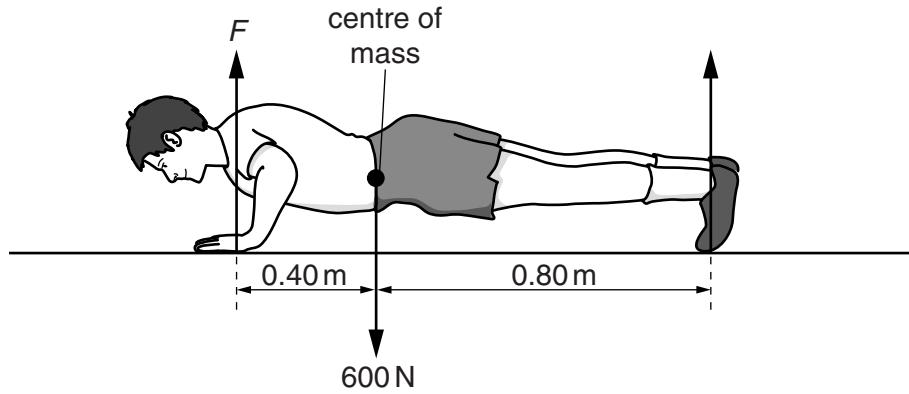

**Fig. 2.1** (not to scale)

The weight of the student is 600 N and this force acts downwards from his centre of mass.

- (a) (i) Explain why the student does work as his body rises from the ground.

.....  
 .....[1]

- (ii) State the form of energy that the student uses to do this work.

.....[1]

- (b) At the position shown in Fig. 2.1, the student is stationary.  
 The weight of the student causes a moment about his toes.

- (i) Calculate the moment of the weight of the student about his toes.

moment = .....[1]

- (ii) Calculate the value of the force  $F$ .

$F =$  .....[2]

- 3 An experiment is carried out to find how the pressure of a fixed mass of air at room temperature varies with volume. Fig. 3.1 shows the apparatus used. The syringe is sealed at one end and the piston is free to move up and down as different metal weights are used.

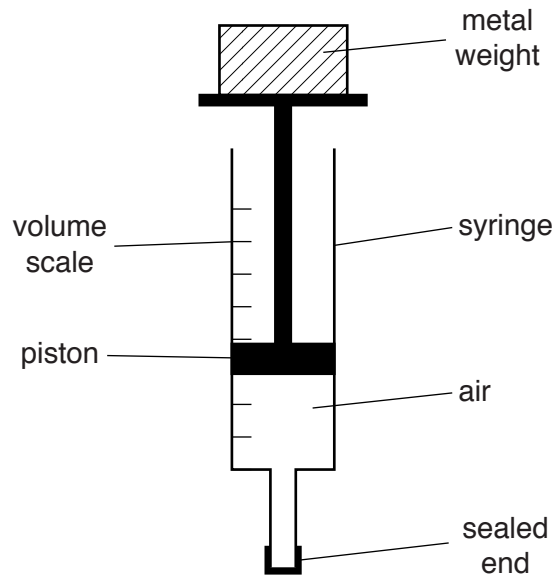

Fig. 3.1

- (a) State the unit in which pressure is measured.

.....[1]

- (b) Fig. 3.2 shows the axes for a graph of pressure against volume for the air in the syringe.

One point is plotted on the graph at pressure of  $P_0$  and volume  $V_0$ .

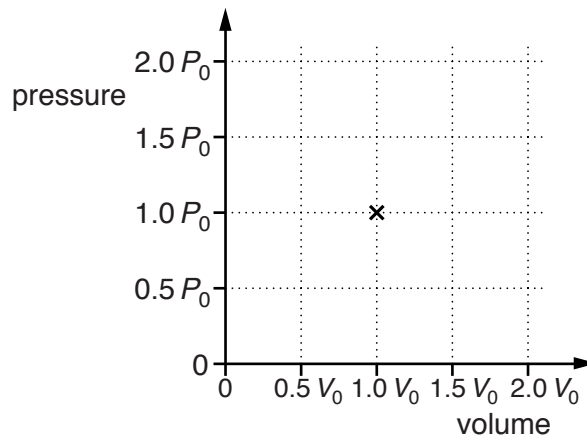

Fig. 3.2

The temperature of the air is kept constant.

On Fig. 3.2,

- (i) plot points at volumes of  $0.5 V_0$  and  $2.0 V_0$ , [1]  
 (ii) complete the graph. [1]

(c) More metal weights are placed on top of the syringe.

Explain how the molecules of air inside the syringe are able to support more metal weights.

.....

.....

.....

.....

.....

.....

.....

.....

.....

.....

.....[3]

4 Fig. 4.1 shows a wave on a string. The wave is travelling towards the right.

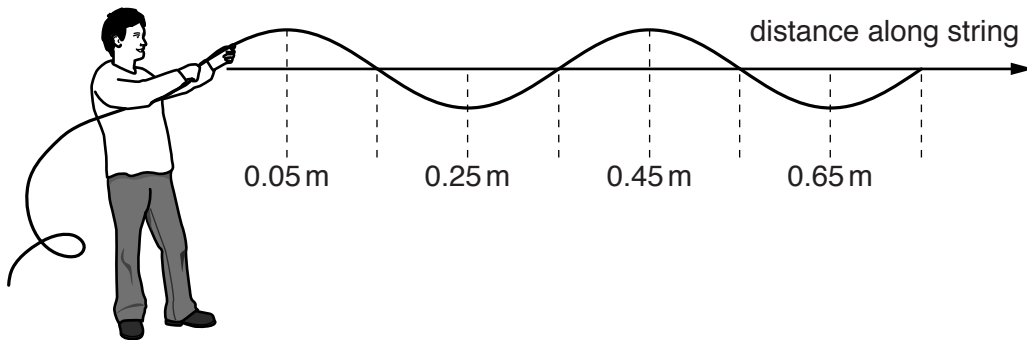

**Fig. 4.1**

(a) Describe the movement of the particles of the string.

.....

.....

.....

.....[2]

(b) Determine the wavelength of the wave.

wavelength = .....[1]

(c) The speed of the wave is 2.0 m/s.

(i) Calculate the frequency of the wave.

frequency = .....[2]

(ii) On Fig. 4.1, draw the string at a time 0.10 s later than the time in Fig. 4.1. [1]

5 Fig. 5.1 shows a ray of light entering and passing along an optical fibre.

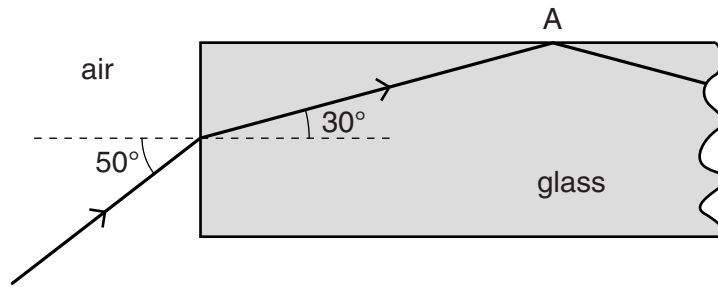

Fig. 5.1

(a) Calculate the refractive index of the glass in the optical fibre.

refractive index = .....[2]

(b) Explain why the ray of light is totally internally reflected at A.

.....  
.....  
.....[2]

(c) Both optical fibre and copper wire are used to transmit data.

Optical fibre is cheaper and can carry more data per second than copper wire.

State one other advantage of using optical fibre rather than copper wire to transmit data.

.....  
.....[1]

- 6 Fig. 6.1 shows a circuit that contains a resistor connected to a power supply of 6.0V and a lamp L.

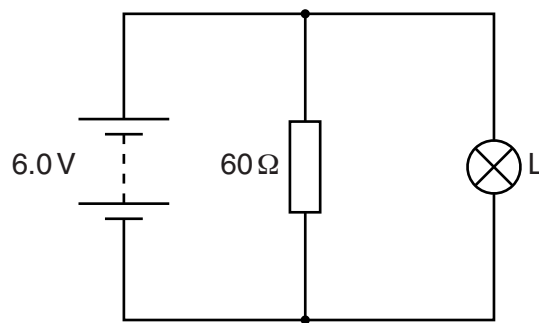

**Fig. 6.1**

The resistor has a resistance of  $60\Omega$ . The lamp is marked 6.0V, 0.90W.

**(a)** Calculate

- (i)** the current in the resistor,

current = .....[2]

- (ii)** the current in the power supply.

current = .....[2]



(b) A second lamp is added to the circuit shown in Fig. 6.1.

The second lamp is in series with the  $60\Omega$  resistor, but is **not** in series with lamp L.

(i) In the space below draw a circuit diagram of this new circuit.

The power supply,  $60\Omega$  resistor and lamp L have been drawn for you.

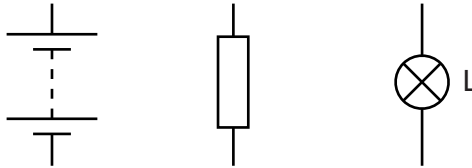

[1]

(ii) The two lamps are identical.

Explain why the second lamp is dimmer than lamp L.

A calculation is not required.

.....

.....

.....[1]

7 A simple apparatus used to demonstrate electromagnetic induction is shown in Fig. 7.1.

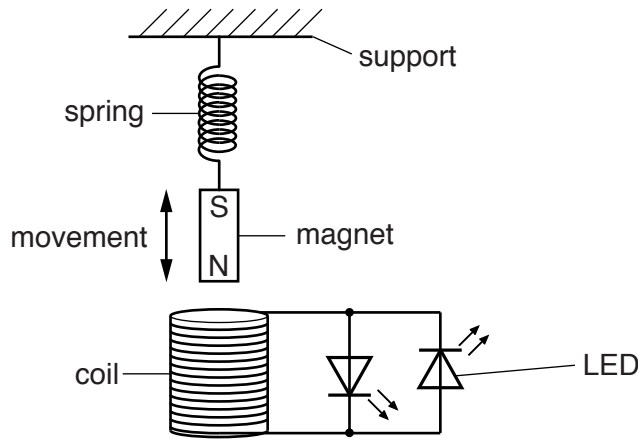

**Fig. 7.1**

The coil is connected to two light-emitting diodes (LEDs). The magnet moves into and out of the coil.

(a) Explain why there is an induced e.m.f. in the coil when the magnet moves.

.....  
 .....  
 .....[2]

(b) Explain why one LED lights up when the magnet moves into the coil and the other LED lights up when the magnet moves out of the coil.

.....  
 .....  
 .....[2]

(c) The LEDs are brighter when the magnet moves faster.  
 Explain why.

.....  
 .....  
 .....[1]

8 Fig. 8.1 shows the basic structure of a cathode-ray oscilloscope (c.r.o.).

Some parts are missing.

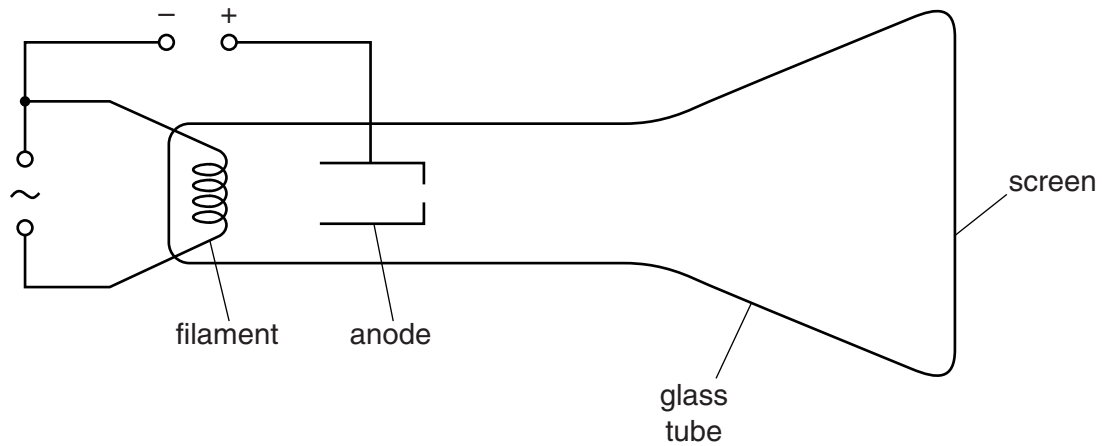

**Fig. 8.1**

Electrons are emitted from the filament by thermionic emission.

(a) Explain what is meant by *thermionic emission*.

.....  
 .....  
 ..... [2]

(b) Electrons hit the screen at high speed.

Explain how the electrons are made to travel at high speed.

.....  
 .....  
 ..... [2]

(c) The spot on the screen is made to move up and down and also across the screen.

The parts of the c.r.o. that make this happen are not shown in Fig. 8.1.

On Fig. 8.1, draw and label the parts that are needed. [2]

**Section B**

Answer **two** questions from this section. Answer in the spaces provided.

9 Fig. 9.1 shows a satellite in orbit around the Earth.

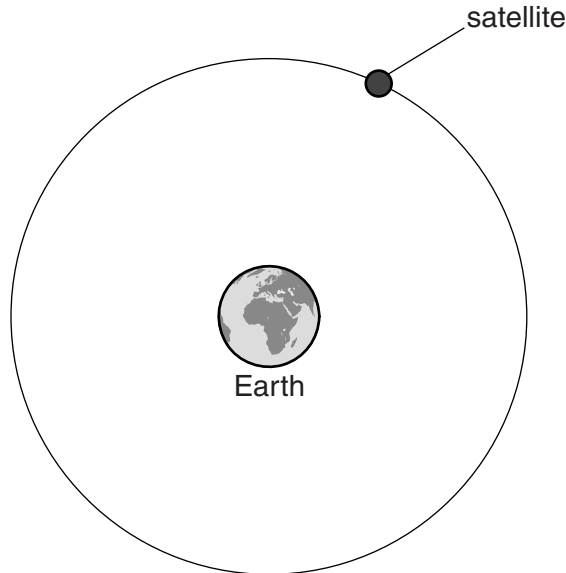

**Fig. 9.1** (not to scale)

(a) The satellite travels at a constant speed in a circular orbit.

(i) Underline the quantities in the list below that are scalars.

acceleration                  force                  mass                  speed                  velocity                  [2]

(ii) The velocity of the satellite changes, but its speed is constant.

1. State what is meant by *velocity*. .....  
.....  
.....[1]

2. Explain why the velocity changes. ....  
.....  
.....[1]

(iii) Explain what makes this satellite move in an orbit that is circular.

.....  
.....  
.....  
.....[2]

(b) The satellite is placed into orbit by a rocket. Fig. 9.2 shows the rocket as it takes off.

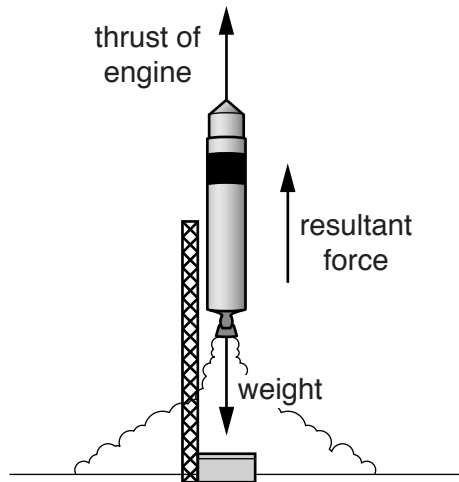

**Fig. 9.2**

The rocket and fuel have a total mass of 40 000 kg and a total weight of 400 000 N. The resultant force acting upwards on the rocket is 50 000 N.

(i) Calculate the thrust produced by the rocket engine.

thrust = .....[1]

(ii) Calculate the acceleration of the rocket.

acceleration = .....[2]

(c) In the first four minutes after take-off, the acceleration of the rocket is uniform.

(i) State what is meant by a *uniform acceleration*.

.....  
 .....  
 .....[2]

(ii) Fig. 9.3 describes the motion of the rocket in the first 12 minutes.

time / minutes	motion of the rocket
0 to 4	uniform acceleration
4 to 6	increasing acceleration
6 to 10	decreasing acceleration
10 to 12	constant speed

**Fig. 9.3**

On Fig. 9.4, sketch the speed-time graph of the rocket for the first 12 minutes.

You do not need to give values for the speed.

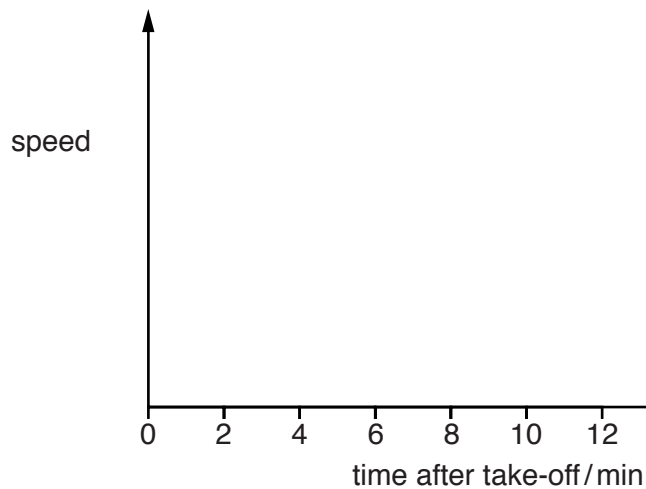

**Fig. 9.4**

[3]

(iii) State how the speed-time graph in (ii) can be used to find the distance travelled by the rocket.

.....  
 .....[1]

10 (a) A student makes a diagram of the molecules in a liquid, as shown in Fig. 10.1.

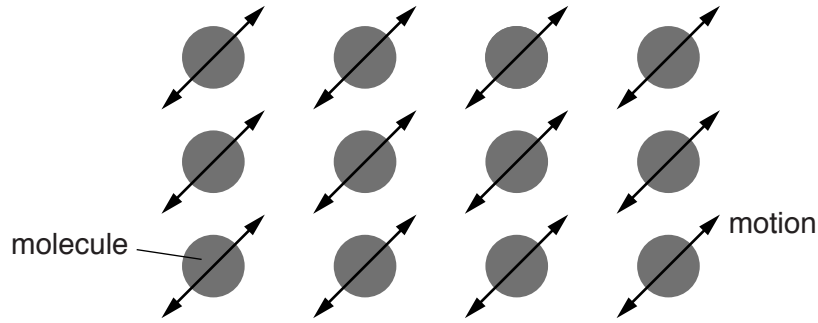

Fig. 10.1

Suggest two ways in which the student's diagram does not show the positions and motion of the molecules accurately.

- 1. ....  
.....
- 2. ....  
.....[2]

(b) Some of the molecules of a liquid evaporate.

(i) Describe what happens during evaporation.  
.....  
.....[1]

(ii) Explain why evaporation has a cooling effect on the liquid.  
.....  
.....  
.....  
.....[2]

- (c) The beaker shown in Fig. 10.2 contains pure water at a temperature of 80°C. A thermometer, initially at room temperature, is placed in the air just above the water. The reading on the thermometer starts to increase slowly.

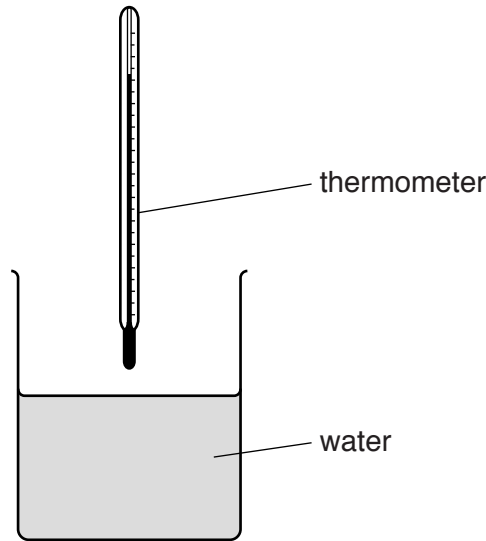

Fig. 10.2

- (i) Explain how convection in the air causes the reading on the thermometer to increase.

.....  
.....[1]

- (ii) A heater is placed underneath the beaker and the water boils vigorously to produce steam. The thermometer reading increases quickly.

Explain how the water in the gas state gives thermal energy (heat) to the thermometer.

.....  
.....  
.....  
.....[2]



- (iii) The heater placed underneath the beaker has a power of 200W.

The mass of water in the beaker is initially 100g.

The water in the beaker is heated for a time of 120s. During this time, the temperature of the water in the beaker rises from 80°C to 100°C and then the water boils. At the end of this time, the mass of water in the beaker is 95g.

The specific heat capacity of water is 4.2 J/(g°C).

The specific latent heat of vaporisation of water is 2250 J/g.

Calculate the thermal energy (heat)

1. produced by the heater in 120 s,

thermal energy = .....[2]

2. used to warm the water from 80°C to 100°C,

thermal energy = .....[2]

3. used to reduce the mass of water in the beaker,

thermal energy = .....[2]

4. produced by the heater that is not transferred to the water.

thermal energy = .....[1]

11 (a) A student makes a model of an atom. The model contains 24 electrons, 25 protons and 26 neutrons. Some of these particles are inside a nucleus at the centre of the model.

(i) Determine the nucleon number (mass number) of the atom.

.....[1]

(ii) Explain why the model represents a charged atom.

.....  
 .....  
 .....[2]

(iii) The student makes a new model of a different isotope of the same element.

Describe the nucleus of this new model.

.....  
 .....  
 .....[2]

(b) Americium-241 is radioactive. Its nuclide notation is  ${}_{94}^{241}\text{Am}$ .

(i) Determine the number of neutrons in a nucleus of americium-241.

number = .....[1]

(ii) A nucleus of americium-241 emits an  $\alpha$ -particle and decays to uranium-237.

Complete the nuclear equation for the decay of americium-241.

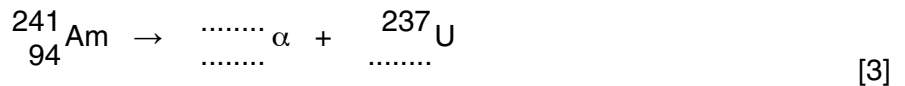

- (c) Geiger and Marsden studied the structure of gold atoms. Fig. 11.1 shows a version of their apparatus. Alpha-particles strike a thin gold foil.

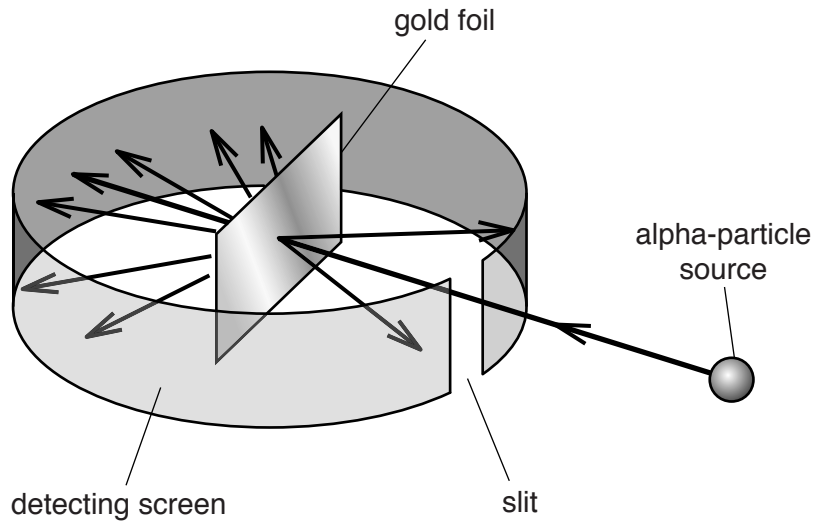

Fig. 11.1

The apparatus shown is in a container from which all the air is removed.

- (i) Suggest why it is necessary to remove all the air from the container.

.....  
.....  
.....[1]

- (ii) The alpha-particles are emitted from the source at random.

Explain why most of the alpha particles from the source do not reach the gold foil.

.....  
.....[1]

