

UNIVERSITY OF CAMBRIDGE INTERNATIONAL EXAMINATIONS
General Certificate of Education Ordinary Level

PHYSICS

5054/03

Paper 3 Practical Test

May/June 2006

2 hours

Additional Materials: As listed in the Confidential Instructions

READ THESE INSTRUCTIONS FIRST

If you have been given an Answer Booklet, follow the instructions on the front cover of the Booklet.
Write your Centre number, candidate number and name on all the work you hand in.
Write in dark blue or black pen.
Do not use staples, paper clips, highlighters, glue or correction fluid.

Answer **all** questions.

For each of the questions in Section A, you will be allowed to work with the apparatus for a maximum of 20 minutes. For the question in Section B, you will be allowed to work with the apparatus for a maximum of 1 hour.

You are expected to record all your observations as soon as these observations are made.
An account of the method of carrying out the experiments is **not** required.

At the end of the examination, hand in only the Answer Booklet.
The number of marks is given in brackets [] at the end of each question or part question.

This document consists of **6** printed pages, **2** blank pages and **1** Answer Booklet.



BLANK PAGE

Section A

Answer **all** questions in this section.

- 1 In this experiment you will measure the ratio of the volume of 20 spheres to the total volume the spheres take up when placed in a beaker.

You have been provided with a 100 cm^3 glass beaker labelled A containing 20 glass spheres, a beaker labelled B containing water, a measuring cylinder, two metre rules and two set squares.

- (a) (i) Place the two metre rules on the bench so that the rules are parallel with a small space between them. Place the 20 glass spheres in this space so that the spheres are touching. The arrangement is shown in Fig. 1.1.
- (ii) Measure and record, on page 3 of your Answer Booklet, the total length L of the line of spheres.
- (iii) Use your answer to (ii) to determine the average diameter D of a sphere.

[1]

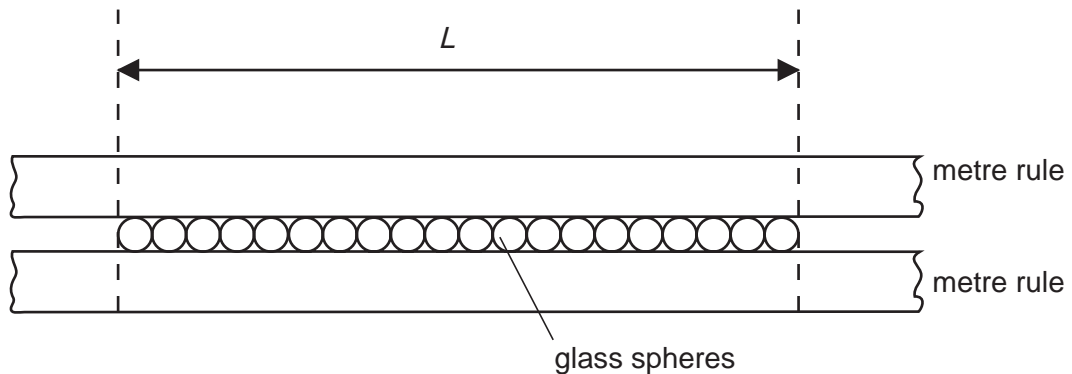

Fig. 1.1

- (b) Explain how you made sure that L was determined as precisely as possible. [1]
- (c) (i) Carefully place the 20 spheres back into beaker A. Pour water from beaker B onto the spheres until the water **just** covers all of the spheres.
- (ii) Use the measuring cylinder to determine the volume V of water in beaker A. [1]
- (d) Calculate the total volume V_s of the 20 spheres using the expression

$$V_s = \frac{10 \pi D^3}{3} . \quad [1]$$

- (e) Calculate the ratio $\frac{V_s}{V_s + V}$. [1]

- 2 In this experiment you will calculate a ratio involving the time for one complete oscillation of a mass-spring system and the extension of the spring.

You have been provided with a spring, a mass, a metre rule, a set square, a stopwatch and a stand with two clamps and two bosses.

- (a) (i) Set up the apparatus as shown in Fig. 2.1.

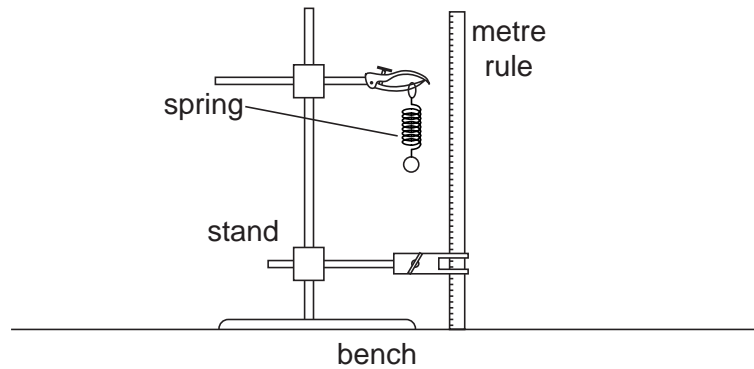

Fig. 2.1

- (ii) Determine the extension x of the spring when the mass is suspended from the spring. Show carefully, on page 4 of your Answer Booklet, all the measurements that you took to determine the extension. [1]
- (b) Explain, with the aid of a diagram, how you made sure that the metre rule was vertical when the extension was determined. [1]
- (c) Remove the metre rule. Carefully pull the mass down a small distance and release it.
- (i) Measure the time for 20 complete oscillations of the mass. One complete oscillation is shown in Fig. 2.2.

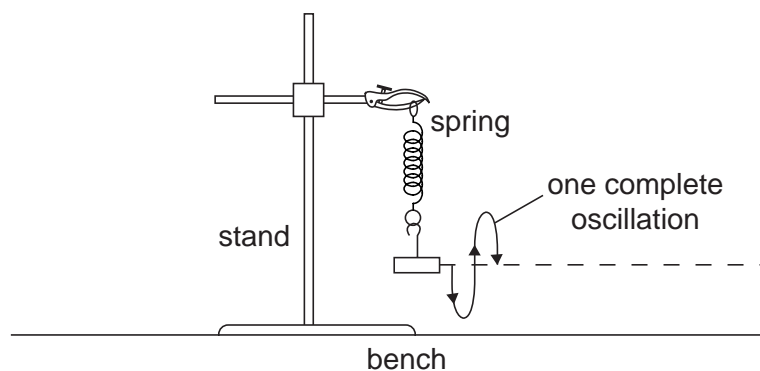

Fig. 2.2

- (ii) State one precaution that you took to make your answer to (i) as precise as possible.
- (iii) Calculate the time T for one complete oscillation. [2]
- (d) Calculate $\frac{T^2}{x}$. [1]

3 *In this experiment you will investigate a parallel circuit.*

You have been provided with a d.c. power supply, an ammeter, a switch and two resistors. The Supervisor has made some connections and has labelled some of the leads.

- (a) On page 5 of your Answer Booklet, draw a circuit diagram of the arrangement that has been set up by the Supervisor. [1]
- (b) Connect lead A to the negative terminal of the power supply. Close the switch. Measure the current I_1 in the resistor R_1 . Open the switch. [1]
- (c) Disconnect lead A from the power supply and connect lead B to the negative terminal of the power supply. Close the switch. Measure the current I_2 in the resistor R_2 . Open the switch. [1]
- (d) Connect both lead A and lead B to the negative terminal of the power supply. Close the switch. Measure the total current I_T in the circuit. Open the switch. [1]
- (e) The resistance of R_1 is $10\ \Omega$. Estimate the resistance of R_2 . [1]

Section B

- 4 In this experiment you will investigate the heating of some water in a beaker by means of a candle flame.

You have been provided with a beaker, a thermometer, a quantity of water at room temperature, a candle, a means of lighting the candle, a plastic stirrer, a stopwatch and a stand with two bosses and one clamp. You have access to a top-pan balance. The thermometer is held in a second clamp and should stay in the clamp throughout the experiment.

- (a) (i) Measure and record, on page 6 of your Answer Booklet, the mass m_B in grams of the empty beaker.
- (ii) Hold the thermometer vertically in the beaker without touching the sides or base of the beaker. Pour sufficient water into the beaker to **just** cover the bulb of the thermometer.
- (iii) Determine the mass m_W in grams of the water in the beaker. [2]
- (b) (i) Light the candle.
- (ii) Set up the apparatus as shown in Fig. 4.1 with the candle away from the beaker.

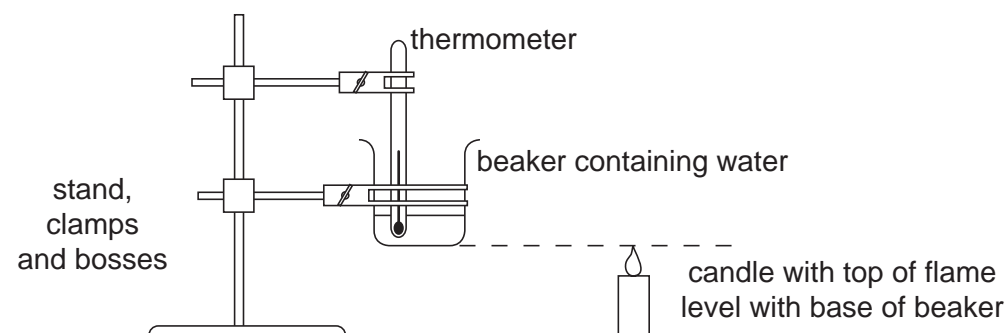

Fig. 4.1

- (iii) Record the temperature θ_R of the water in the beaker. [1]
- (c) Carefully place the lit candle under the base of the beaker and start the stopwatch. Record, in the table on page 6 of your Answer Booklet, the time t and the temperature θ of the water at regular intervals for a period of 300 seconds. [4]
- (d) Using the grid on page 7 of your Answer Booklet, plot a graph of $\theta/^\circ\text{C}$ on the y -axis against t/s on the x -axis. [4]
- (e) Using your graph, determine the rate of rise of temperature with time at $t = 150\text{ s}$. Give the unit of your answer. [2]

(f) The power of the candle flame is given by

$$\text{power} = (m_W c_W + m_B c_B) \times (\text{rate of rise of temperature})$$

where $c_W = 4.2 \text{ J/(g } ^\circ\text{C)}$ and $c_B = 0.67 \text{ J/(g } ^\circ\text{C)}$.

Calculate the power of the candle flame. Give the unit of your answer.

[2]

BLANK PAGE

Permission to reproduce items where third-party owned material protected by copyright is included has been sought and cleared where possible. Every reasonable effort has been made by the publisher (UCLES) to trace copyright holders, but if any items requiring clearance have unwittingly been included, the publisher will be pleased to make amends at the earliest possible opportunity.

University of Cambridge International Examinations is part of the University of Cambridge Local Examinations Syndicate (UCLES), which is itself a department of the University of Cambridge.