



# Cambridge IGCSE™

CANDIDATE  
NAME

--

CENTRE  
NUMBER

--	--	--	--	--

CANDIDATE  
NUMBER

--	--	--	--



**COMBINED SCIENCE**

**0653/61**

Paper 6 Alternative to Practical

**October/November 2021**

**1 hour**

You must answer on the question paper.

No additional materials are needed.

## INSTRUCTIONS

- Answer **all** questions.
- Use a black or dark blue pen. You may use an HB pencil for any diagrams or graphs.
- Write your name, centre number and candidate number in the boxes at the top of the page.
- Write your answer to each question in the space provided.
- Do **not** use an erasable pen or correction fluid.
- Do **not** write on any bar codes.
- You may use a calculator.
- You should show all your working and use appropriate units.

## INFORMATION

- The total mark for this paper is 40.
- The number of marks for each question or part question is shown in brackets [ ].

This document has **20** pages. Any blank pages are indicated.

1 (a) Fig. 1.1 shows two animals, one from a cold climate and one from a hot climate.



**cold climate**



**hot climate**

**Fig. 1.1**

The animal from the cold climate is much larger than the animal from the hot climate.

Identify **two** other visible differences which can be seen in Fig. 1.1.

1 .....

.....

2 .....

.....

[2]

(b) A student investigates heat loss in animals of different sizes.

Two beakers of different sizes represent the animals:

- A large beaker represents a large animal.
- A small beaker represents a small animal.

### Procedure

The student:

- clamps one thermometer in a large beaker and another thermometer in a small beaker, as shown in Fig. 1.2

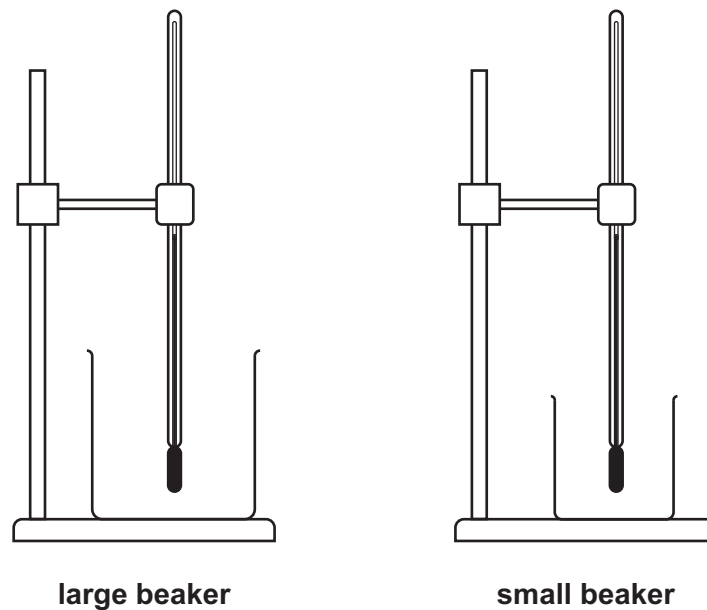

Fig. 1.2

- adds approximately  $200\text{ cm}^3$  of hot water to the large beaker
- adds approximately  $50\text{ cm}^3$  of hot water to the small beaker
- records both temperatures in Table 1.1
- records in Table 1.1 the temperature in each beaker every 60 seconds for 300 seconds.

(i) Fig. 1.3 shows the readings on the thermometers at 60 seconds.

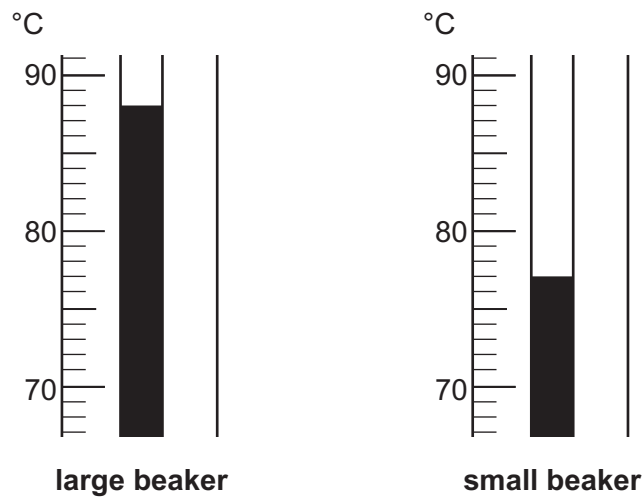

Fig. 1.3

Record in Table 1.1 the temperature of the hot water in each beaker at 60 seconds.

Table 1.1

time /seconds	temperature of water in <b>large</b> beaker /°C	temperature of water in <b>small</b> beaker /°C
0	91	82
60		
120	84	72
180	81	67
240	78	63
300	75	59

[2]

(ii) Calculate the temperature change of the water in **each** beaker.

Use the equation shown.

$$\text{temperature change} = (\text{temperature at 0 seconds}) - (\text{temperature at 300 seconds})$$

temperature change in **large** beaker = ..... °C

temperature change in **small** beaker = ..... °C

[1]

(c) You are going to plot a graph of temperature against time for **both** beakers **on the same axes**.

- Use a scale for the temperature axis that is suitable for **both** beakers. You do **not** need to start the scale at zero.
- Plot the points for the **large** beaker.
- Draw the smooth best-fit curve. Label this curve **L**.
- Plot the points for the **small** beaker.
- Draw the smooth best-fit curve. Label this curve **S**.

temperature/°C

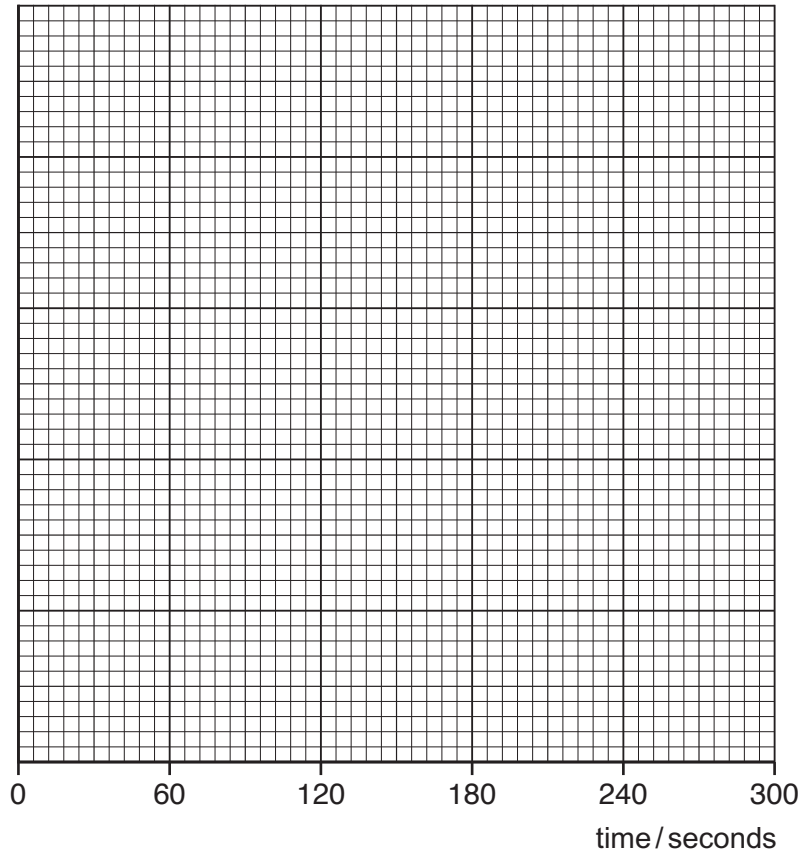

[4]

(d) Compare the temperature changes of the water in each beaker.

.....

.....

.....

..... [2]

(e) Suggest which animal, large or small, loses heat more quickly.

Explain your choice using your answers to (b)(ii) and (c).

animal .....

explanation .....

..... [1]

(f) Suggest **one** improvement to the procedure which gives a fairer comparison of the rate of heat loss from the beakers.

.....

..... [1]

[Total: 13]

**BLANK PAGE**

2 A student prepares a sample of the blue salt, copper(II) sulfate.

The student reacts copper(II) carbonate with dilute sulfuric acid.

Copper(II) carbonate is a green insoluble solid.

**(a) Procedure**

The student:

- step 1 puts  $20\text{ cm}^3$  of dilute sulfuric acid into a beaker
- step 2 adds excess copper(II) carbonate
- step 3 stirs the mixture until the mixture stops fizzing
- step 4 filters the mixture into a flask
- step 5 keeps the filtrate of copper(II) sulfate in the flask to make crystals.

(i) Name a piece of apparatus suitable for measuring  $20\text{ cm}^3$  of dilute sulfuric acid in step 1.

..... [1]

(ii) The student tests the gas given off in step 3.

The gas turns limewater milky.

Name the gas given off.

..... [1]

(iii) Describe the appearance of the residue in the filter paper and the filtrate in the flask in step 4.

residue .....

filtrate .....

[2]



- (iv) Describe, in detail, how to make large crystals of copper(II) sulfate from the filtrate.

.....  
.....  
.....  
.....  
.....  
..... [3]

- (b) The filtrate contains both copper(II) ions and sulfate ions.

The student does some tests on the filtrate.

- (i) The student adds aqueous ammonia until it is in excess to a sample of the filtrate.

Describe what the student observes.

.....  
.....  
.....  
..... [2]

- (ii) The student uses two reagents to test for the presence of aqueous sulfate ions.

Tick (✓) **two** boxes to identify the reagents.

aqueous barium nitrate

dilute nitric acid

aqueous sodium hydroxide

aqueous silver nitrate

dilute sulfuric acid

<input type="checkbox"/>
<input type="checkbox"/>
<input type="checkbox"/>
<input type="checkbox"/>
<input type="checkbox"/>

[1]

(c) A student does a flame test.

The student:

- cleans a flame test wire
- dips the flame test wire into a sample of solid copper(II) sulfate
- places the wire in the top of a blue Bunsen burner flame
- observes a blue-green and yellow flame.

(i) Suggest why the student cleans the flame test wire.

.....  
..... [1]

(ii) Explain why the student thinks the sample of copper(II) sulfate is **not** pure.

..... [1]

(iii) Suggest why it is important to use a blue Bunsen burner flame rather than a yellow Bunsen burner flame in the flame test.

.....  
..... [1]

[Total: 13]

**BLANK PAGE**

3 A student determines the density of a cork.

(a) The student determines the volume of the cork using the method of displacement.

### Procedure

The student:

- adds  $70.0\text{ cm}^3$  of water to a measuring cylinder
- lowers a metal object into the water using a thin cotton thread
- records the total volume of the water and metal object
- removes the metal object and attaches the cork to it
- lowers the metal object and cork into the water
- records the total volume of the water, metal object and cork.

Fig. 3.1 shows the procedure.

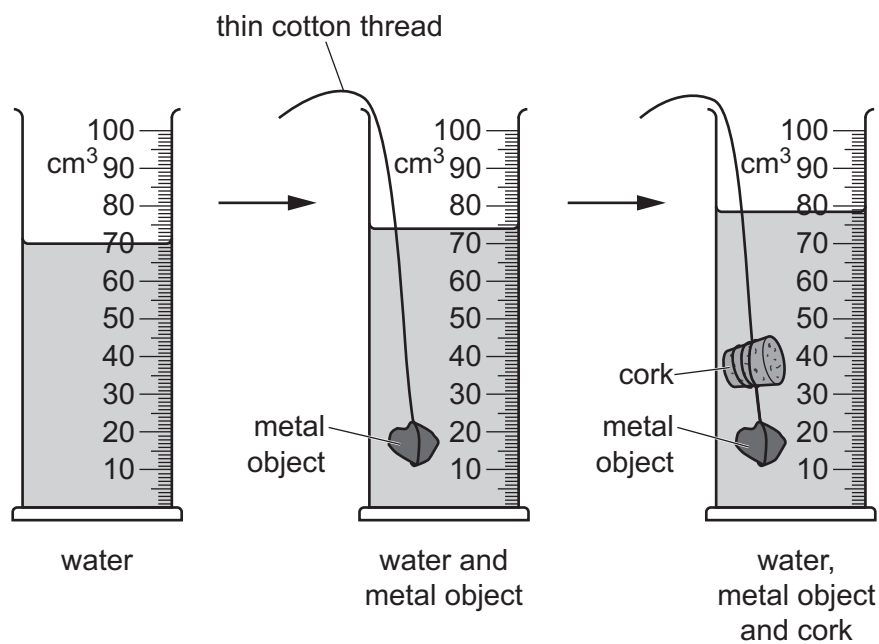
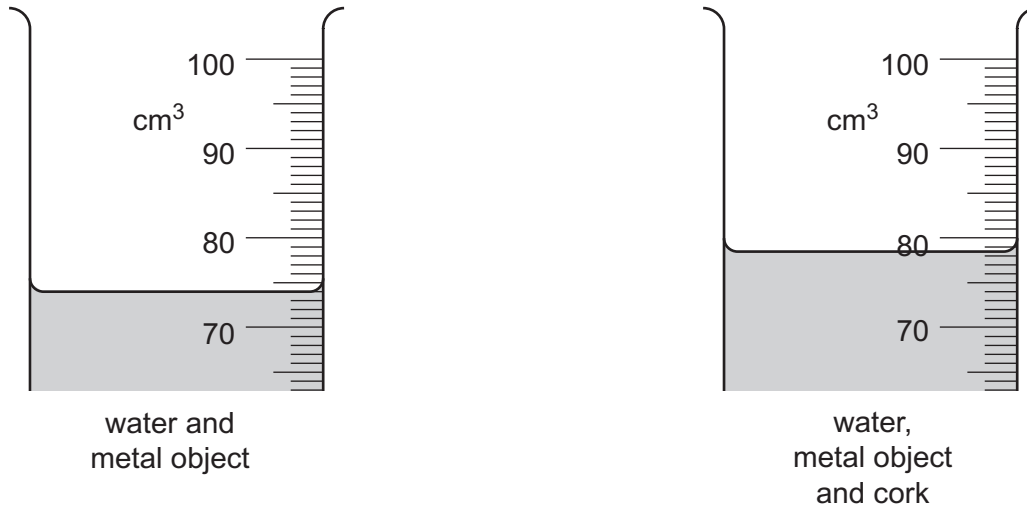

Fig. 3.1

- (i) State one precaution the student takes when reading the level of water in the measuring cylinder.

.....  
 ..... [1]

- (ii) Fig. 3.2 shows the levels of water in the measuring cylinder for the water and metal object and the water, metal object and cork.



**Fig. 3.2**

Record in Table 3.1 the volumes shown in Fig. 3.2.

**Table 3.1**

contents of measuring cylinder	volume /cm <sup>3</sup>
water and metal object	
water, metal object and cork	

[2]

- (iii) Use the volumes in Table 3.1 to calculate the volume of the cork.

Use the equation shown.

$$\text{volume of cork} = \text{volume of water, metal object and cork} - \text{volume of water and metal object}$$

volume of cork = ..... cm<sup>3</sup> [1]

(b) The student uses a balance to measure the mass of the cork.

The mass of the cork is 1.9g.

Calculate the density of the cork.

Use the equation shown.

$$\text{density} = \frac{\text{mass}}{\text{volume}}$$

Give your answer to **two** significant figures.

density of cork = ..... g/cm<sup>3</sup> [2]

(c) Cork floats on water.

Suggest why the metal object is needed in this experiment.

.....  
..... [1]

[Total: 7]

**BLANK PAGE**

4 A student has clothes made of three different materials: cotton, polyester and wool.

After washing the clothes, the student observes the wet clothes becoming dry as the water evaporates.

The student wants to know if the material of the clothes affects the rate at which the water evaporates.

Plan an investigation to determine how the **material** of the clothes affects the **rate of evaporation** of water from the clothes.

You are provided with:

- samples of cotton, polyester and wool
- water

You may use any common laboratory apparatus in your plan.

Include in your plan:

- the apparatus needed
- a brief description of the method, explaining any safety precautions you will take
- what you will measure
- which variables you will keep constant
- how you will process your results to draw a conclusion.

You may include a labelled diagram.

You may include a results table (you are not required to enter any readings in the table).

.....

.....

.....

.....

.....



.....  
.....  
.....  
.....  
.....  
.....  
.....  
.....  
.....  
.....

[7]

**BLANK PAGE**

**BLANK PAGE**

**BLANK PAGE**

---

Permission to reproduce items where third-party owned material protected by copyright is included has been sought and cleared where possible. Every reasonable effort has been made by the publisher (UCLES) to trace copyright holders, but if any items requiring clearance have unwittingly been included, the publisher will be pleased to make amends at the earliest possible opportunity.

To avoid the issue of disclosure of answer-related information to candidates, all copyright acknowledgements are reproduced online in the Cambridge Assessment International Education Copyright Acknowledgements Booklet. This is produced for each series of examinations and is freely available to download at [www.cambridgeinternational.org](http://www.cambridgeinternational.org) after the live examination series.

Cambridge Assessment International Education is part of the Cambridge Assessment Group. Cambridge Assessment is the brand name of the University of Cambridge Local Examinations Syndicate (UCLES), which itself is a department of the University of Cambridge.