



Cambridge IGCSE™

COMBINED SCIENCE

0653/22

Paper 2 Multiple Choice (Extended)

October/November 2021

45 minutes

You must answer on the multiple choice answer sheet.

You will need: Multiple choice answer sheet
Soft clean eraser
Soft pencil (type B or HB is recommended)

INSTRUCTIONS

- There are **forty** questions on this paper. Answer **all** questions.
- For each question there are four possible answers **A, B, C** and **D**. Choose the **one** you consider correct and record your choice in soft pencil on the multiple choice answer sheet.
- Follow the instructions on the multiple choice answer sheet.
- Write in soft pencil.
- Write your name, centre number and candidate number on the multiple choice answer sheet in the spaces provided unless this has been done for you.
- Do **not** use correction fluid.
- Do **not** write on any bar codes.
- You may use a calculator.

INFORMATION

- The total mark for this paper is 40.
- Each correct answer will score one mark.
- Any rough working should be done on this question paper.
- The Periodic Table is printed in the question paper.

This document has **16** pages.



1 Movement is a characteristic of all living organisms.

Which two other characteristics of living organisms provide the energy for movement?

- A excretion and nutrition
- B growth and sensitivity
- C nutrition and respiration
- D respiration and growth

2 The diagrams show three different specialised cells.

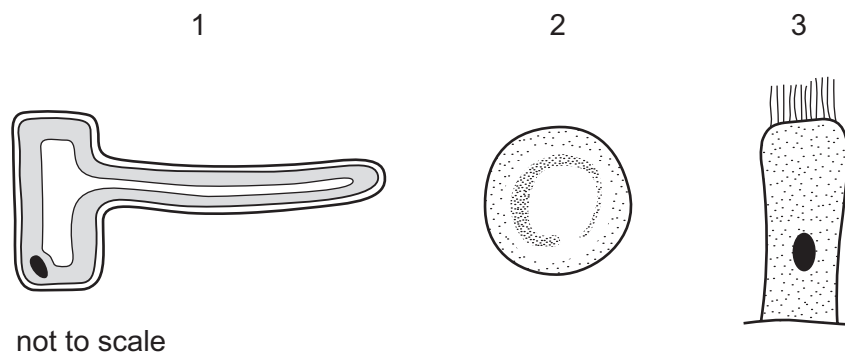

Which row shows the correct functions of cells 1, 2 and 3?

	1	2	3
A	absorbs water	transports oxygen	moves mucus
B	absorbs water	transports oxygen	absorbs digested food
C	transports oxygen	absorbs water	moves mucus
D	transports oxygen	absorbs water	absorbs digested food

3 A biological molecule is analysed and found to contain carbon, oxygen, hydrogen and nitrogen.

What is this biological molecule?

- A fat
- B glucose
- C protein
- D starch

- 4 The graph shows the effect of pH on the activity of an enzyme.

Where on the graph would collisions between enzyme and substrate be most effective?

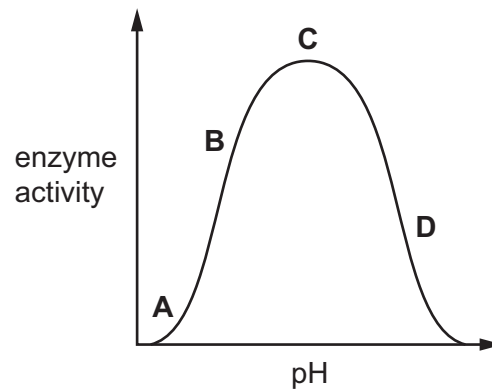

- 5 Which letters from the list represent the balanced equation for photosynthesis?

P	$C_6H_{12}O_6$	T	H_2O
Q	$6C_6H_{12}O_6$	U	$6H_2O$
R	CO_2	V	O_2
S	$6CO_2$	W	$6O_2$

- A** $P + U \rightarrow R + V$
B $Q + T \rightarrow S + U$
C $R + T \rightarrow W + P$
D $U + S \rightarrow P + W$

- 6 During pregnancy, a woman is told she is iron-deficient.

Which food could she eat to increase the iron content in her diet?

- A** cheese
B fruit
C milk
D red meat

7 The diagram shows part of the alimentary canal and associated structures.

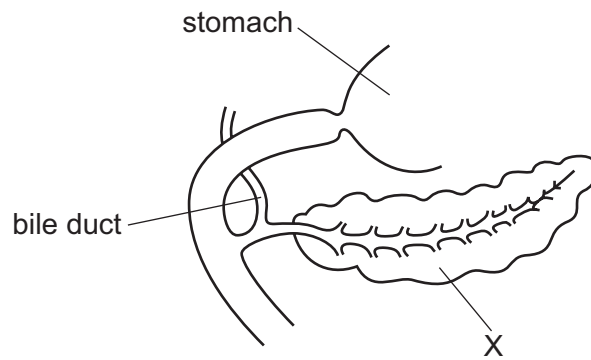

Which row correctly identifies structure X, an enzyme secreted by structure X and the action of this enzyme?

	structure X	enzyme	action of enzyme
A	liver	amylase	converts proteins to amino acids
B	pancreas	amylase	converts starch to simple sugars
C	liver	protease	converts proteins to amino acids
D	pancreas	protease	converts starch to simple sugars

- 8 The graph shows the rate and depth of breathing of a student at rest.

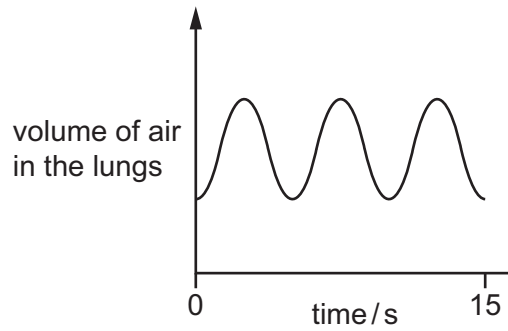

Which graph shows the rate and depth of breathing of the student immediately after five minutes of physical activity?

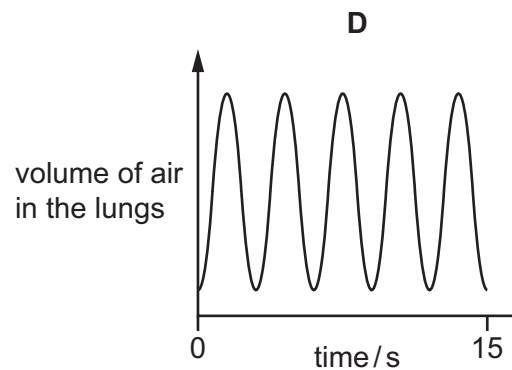
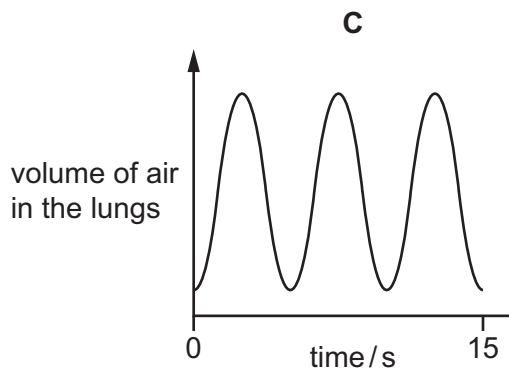
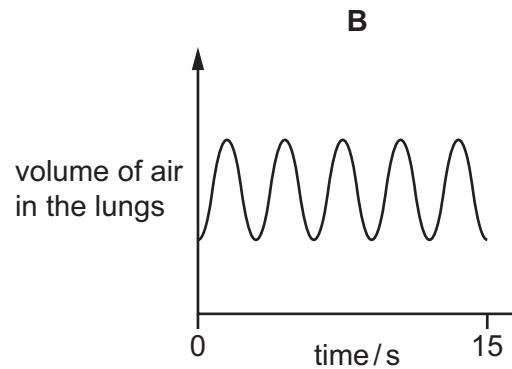
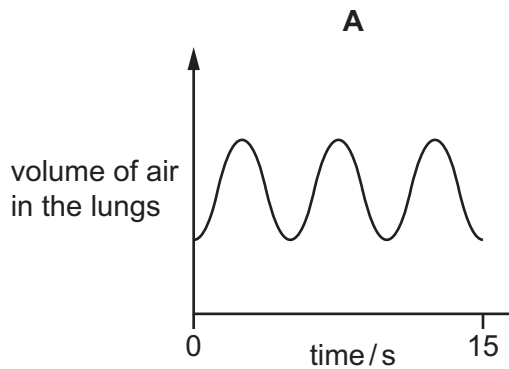

- 9 A plant shoot is illuminated from one side only.

What collects on the shaded side of the plant shoot?

- A auxin
- B chlorophyll
- C glucose
- D starch

10 Which row is correct for sexual reproduction?

	gametes are formed	offspring genetically identical to parents
A	no	no
B	yes	no
C	no	yes
D	yes	yes

11 Which row correctly describes features of human egg cells and sperm cells?

	egg cells	sperm cells
A	energy stores present	enzymes present
B	enzymes present	energy stores present
C	produced in large numbers	flagellum present
D	flagellum present	produced in large numbers

12 The diagram represents four organisms in a food chain.

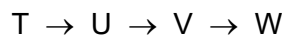

Which organisms are consumers?

- A** T, U and V **B** T, U and W **C** T, V and W **D** U, V and W

13 During eutrophication, what is the **main** reason for the increased growth of producers?

- A** increased availability of carbon dioxide
B increased availability of nitrate
C increased availability of oxygen
D increased availability of water

14 Which dot-and-cross diagram represents the bonding in a molecule of carbon dioxide?



15 Copper forms two different ions, Cu^{2+} and Cu^+ .

Copper forms two different oxides.

What are the formulae of these two oxides?

- A CuO_2 and Cu_2O
- B Cu_2O_2 and CuO
- C Cu_2O_2 and CuO_2
- D CuO and Cu_2O

16 Which statements about bond breaking and bond forming are correct?

- 1 Bond breaking is endothermic.
- 2 Bond breaking is exothermic.
- 3 Bond forming is endothermic.
- 4 Bond forming is exothermic.

- A 1 and 3 B 1 and 4 C 2 and 3 D 2 and 4

17 Hydrogen peroxide decomposes to form water and oxygen.

Which changes in temperature and in concentration **both** reduce the rate of this reaction?

	temperature of hydrogen peroxide	concentration of hydrogen peroxide
A	decrease	decrease
B	decrease	increase
C	increase	decrease
D	increase	increase

- 18 Aluminium reacts with iron oxide to produce iron.

The equation is shown.

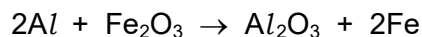

Which row identifies the oxidising agent and the reducing agent?

	oxidising agent	reducing agent
A	Fe	Al
B	Fe	Al ₂ O ₃
C	Fe ₂ O ₃	Al
D	Fe ₂ O ₃	Al ₂ O ₃

- 19 Ammonia dissolves in water.

Which test shows that the solution has a pH of 9?

- A** Blue litmus paper stays blue.
B Red litmus paper turns blue.
C Universal indicator paper turns green.
D Universal indicator paper turns blue.
- 20 A piece of damp blue litmus paper is placed in a gas.

The litmus paper turns red and then turns white.

What is the gas?

- A** carbon dioxide
B chlorine
C hydrogen
D oxygen
- 21 Fluorine is an element in Group VII of the Periodic Table.

Which statement about fluorine is correct?

- A** Fluorine is a metal with a low melting point.
B Fluorine is a gas and is less reactive than bromine.
C Fluorine molecules are diatomic.
D Chlorine displaces fluorine from its compounds.

22 Which statement about transition elements is **not** correct?

- A They can act as catalysts.
- B They can be metals or non-metals.
- C They have high densities.
- D They have high melting points.

23 Brass is an alloy.

What is brass?

- A a compound containing two metallic elements
- B a compound containing two non-metallic elements
- C a mixture containing two metallic elements
- D a mixture containing two non-metallic elements

24 Which two substances react together?

- A aluminium and aqueous magnesium sulfate
- B copper and aqueous iron(II) sulfate
- C iron and aqueous zinc sulfate
- D zinc and aqueous copper sulfate

25 Which row shows how copper can be obtained from copper oxide?

	heat copper oxide with carbon	electrolysis of molten copper oxide
A	✓	✓
B	✓	x
C	x	✓
D	x	x

26 Magnesium carbonate reacts with dilute hydrochloric acid.

Calcium carbonate decomposes when heated.

Which gas is produced in **both** reactions?

- A carbon dioxide
- B carbon monoxide
- C chlorine
- D hydrogen

27 The fractional distillation of petroleum is shown.

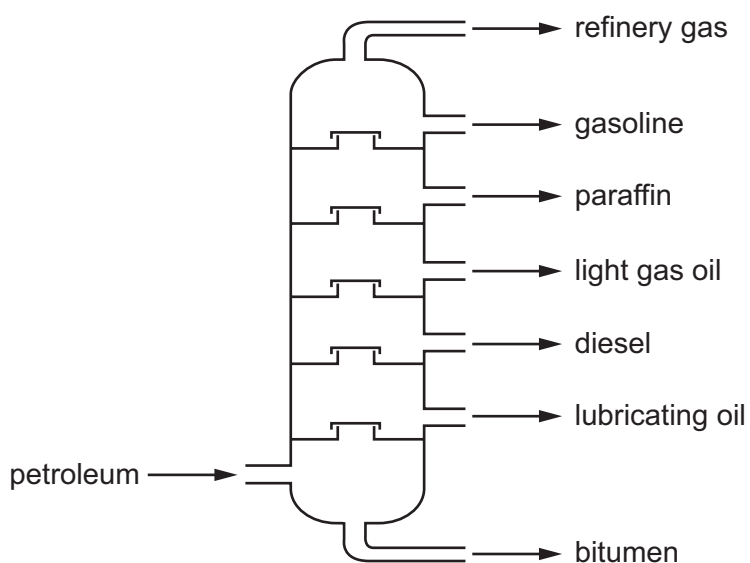

Which fraction contains molecules that have the largest attractive forces?

- A bitumen
- B diesel
- C gasoline
- D refinery gas

- 28 A car accelerates from rest at a constant rate. It then moves with constant speed and finally comes to rest with non-constant deceleration.

Which diagram shows the speed–time graph for the car?

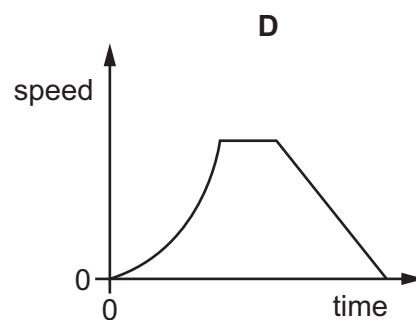
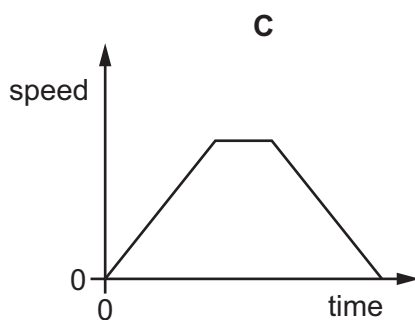
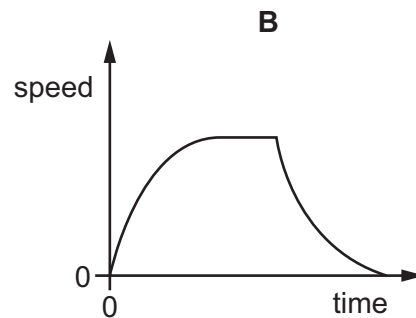
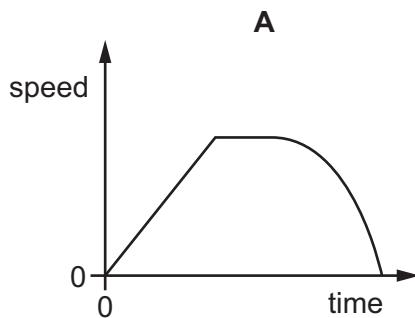

- 29 Four planets have different gravitational field strengths.

An object has a mass of 50 kg.

Which gravitational field strength causes the object to have a weight of 450 N?

	<u>gravitational field strength</u> N/kg
A	4.5
B	5.0
C	9.0
D	10.0

- 30 Which process is the source of the energy released from the Sun?

- A** chemical reactions
- B** geothermal heating
- C** nuclear fission
- D** nuclear fusion

31 Which statements about liquids and gases are correct?

- 1 Molecules in gases are further apart than molecules in liquids.
- 2 Molecules in liquids and gases are arranged randomly.
- 3 When a liquid evaporates, the temperature of the remaining liquid decreases.

A 1 and 2 only **B** 1 and 3 only **C** 2 and 3 only **D** 1, 2 and 3

32 The bottom of a container of water is heated.

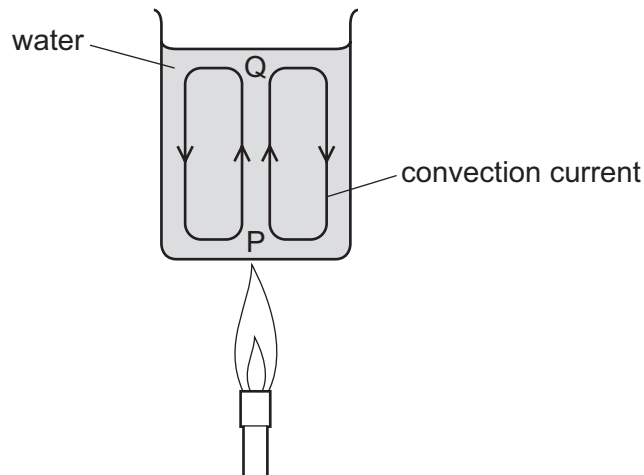

A convection current forms and water rises from P to Q.

Which statement is correct?

- A** Water at P expands and decreases in density.
- B** Water at P expands and increases in density.
- C** Water at Q expands and decreases in density.
- D** Water at Q expands and increases in density.

33 A microwave oven uses microwaves with a frequency of 2.5×10^9 Hz.

What is the wavelength of these microwaves?

- A** 0.0075 m **B** 0.12 m **C** 7.5 m **D** 12 m

34 A ray of light passes through a glass window.

Which path does it take?

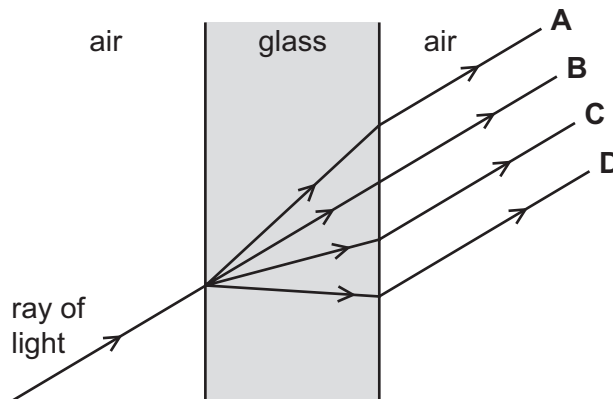

35 A thin converging lens is used as a magnifying glass.

The focal length of the lens is 5.0 cm.

How far from the lens is the object placed?

- A less than 5.0 cm
- B between 5.0 cm and 10 cm
- C 10 cm
- D more than 10 cm

36 A lightning strike transfers 20 C of charge in 5.0×10^{-4} s.

What is the average current during the lightning strike?

- A 2.5×10^{-5} A B 1.0×10^{-2} A C 1.0×10^2 A D 4.0×10^4 A

- 37 A circuit contains a battery connected to a resistor.

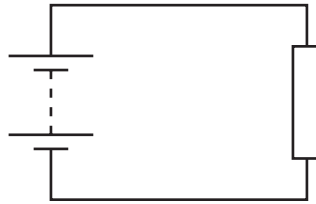

Which values of electromotive force (e.m.f.) and resistance produce the smallest current in the circuit?

	e.m.f./V	resistance/ Ω
A	6.0	10
B	6.0	20
C	24	80
D	24	160

- 38 Four wires are made from the same material but have different lengths and diameters.

Which wire has the smallest resistance?

	length / cm	diameter / mm
A	50	0.10
B	50	0.20
C	100	0.10
D	100	0.20

- 39 The diagrams show four circuits, each containing an ammeter and two lamps with different resistances.

Which circuit shows an ammeter with a reading equal to the current in each lamp?

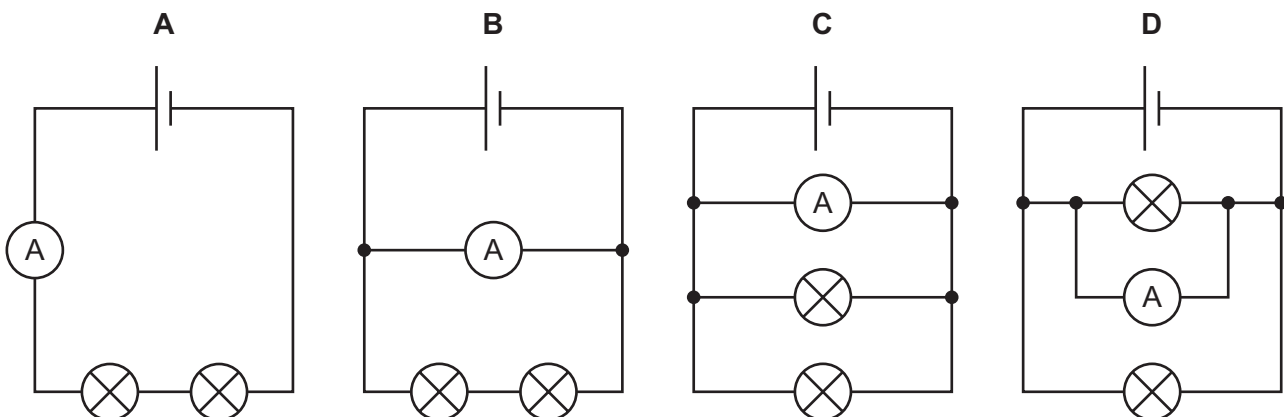

40 The diagram shows a circuit with four labelled components.

One component breaks the circuit automatically when the current becomes too large.

Which component does this?

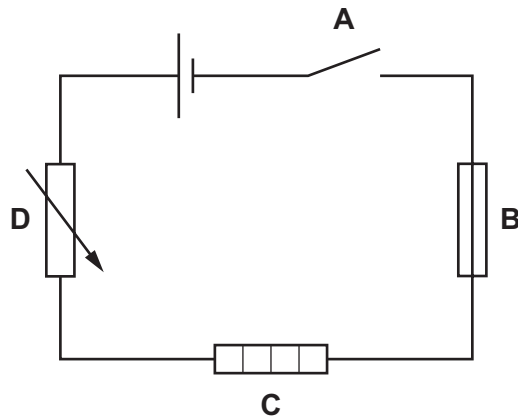

Permission to reproduce items where third-party owned material protected by copyright is included has been sought and cleared where possible. Every reasonable effort has been made by the publisher (UCLES) to trace copyright holders, but if any items requiring clearance have unwittingly been included, the publisher will be pleased to make amends at the earliest possible opportunity.

To avoid the issue of disclosure of answer-related information to candidates, all copyright acknowledgements are reproduced online in the Cambridge Assessment International Education Copyright Acknowledgements Booklet. This is produced for each series of examinations and is freely available to download at www.cambridgeinternational.org after the live examination series.

Cambridge Assessment International Education is part of the Cambridge Assessment Group. Cambridge Assessment is the brand name of the University of Cambridge Local Examinations Syndicate (UCLES), which itself is a department of the University of Cambridge.

The Periodic Table of Elements

Group																	
I	II	III										IV	V	VI	VII	VIII	
3 Li lithium 7	4 Be beryllium 9	<div style="border: 1px solid black; padding: 5px; text-align: center;"> Key atomic number atomic symbol name relative atomic mass </div>										6 C carbon 12	7 N nitrogen 14	8 O oxygen 16	9 F fluorine 19	10 Ne neon 20	
11 Na sodium 23	12 Mg magnesium 24											5 B boron 11	13 Al aluminium 27	14 Si silicon 28	15 P phosphorus 31	16 S sulfur 32	17 Cl chlorine 35.5
19 K potassium 39	20 Ca calcium 40	21 Sc scandium 45	22 Ti titanium 48	23 V vanadium 51	24 Cr chromium 52	25 Mn manganese 55	26 Fe iron 56	27 Co cobalt 59	28 Ni nickel 59	29 Cu copper 64	30 Zn zinc 65	31 Ga gallium 70	32 Ge germanium 73	33 As arsenic 75	34 Se selenium 79	35 Br bromine 80	36 Kr krypton 84
37 Rb rubidium 85	38 Sr strontium 88	39 Y yttrium 89	40 Zr zirconium 91	41 Nb niobium 93	42 Mo molybdenum 96	43 Tc technetium —	44 Ru ruthenium 101	45 Rh rhodium 103	46 Pd palladium 106	47 Ag silver 108	48 Cd cadmium 112	49 In indium 115	50 Sn tin 119	51 Sb antimony 122	52 Te tellurium 128	53 I iodine 127	54 Xe xenon 131
55 Cs caesium 133	56 Ba barium 137	57–71 lanthanoids	72 Hf hafnium 178	73 Ta tantalum 181	74 W tungsten 184	75 Re rhenium 186	76 Os osmium 190	77 Ir iridium 192	78 Pt platinum 195	79 Au gold 197	80 Hg mercury 201	81 Tl thallium 204	82 Pb lead 207	83 Bi bismuth 209	84 Po polonium —	85 At astatine —	86 Rn radon —
87 Fr francium —	88 Ra radium —	89–103 actinoids	104 Rf rutherfordium —	105 Db dubnium —	106 Sg seaborgium —	107 Bh bohrium —	108 Hs hassium —	109 Mt meitnerium —	110 Ds darmstadtium —	111 Rg roentgenium —	112 Cn copernicium —	114 Fl flerovium —	116 Lv livermorium —	—	—	—	—

lanthanoids	actinoids
57 La lanthanum 139	89 Ac actinium —
58 Ce cerium 140	90 Th thorium 232
59 Pr praseodymium 141	91 Pa protactinium 231
60 Nd neodymium 144	92 U uranium 238
61 Pm promethium —	93 Np neptunium —
62 Sm samarium 150	94 Pu plutonium —
63 Eu europium 152	95 Am americium —
64 Gd gadolinium 157	96 Cm curium —
65 Tb terbium 159	97 Bk berkelium —
66 Dy dysprosium 163	98 Cf californium —
67 Ho holmium 165	99 Es einsteinium —
68 Er erbium 167	100 Fm fermium —
69 Tm thulium 169	101 Md mendelevium —
70 Yb ytterbium 173	102 No nobelium —
71 Lu lutetium 175	103 Lr lawrencium —

The volume of one mole of any gas is 24 dm³ at room temperature and pressure (r.t.p.).