



Cambridge IGCSE™

COMBINED SCIENCE

0653/11

Paper 1 Multiple Choice (Core)

October/November 2020

45 minutes

You must answer on the multiple choice answer sheet.

You will need: Multiple choice answer sheet
Soft clean eraser
Soft pencil (type B or HB is recommended)

INSTRUCTIONS

- There are **forty** questions on this paper. Answer **all** questions.
- For each question there are four possible answers **A, B, C** and **D**. Choose the **one** you consider correct and record your choice in soft pencil on the multiple choice answer sheet.
- Follow the instructions on the multiple choice answer sheet.
- Write in soft pencil.
- Write your name, centre number and candidate number on the multiple choice answer sheet in the spaces provided unless this has been done for you.
- Do **not** use correction fluid.
- Do **not** write on any bar codes.
- You may use a calculator.

INFORMATION

- The total mark for this paper is 40.
- Each correct answer will score one mark. A mark will not be deducted for a wrong answer.
- Any rough working should be done on this question paper.
- The Periodic Table is printed in the question paper.

This document has **16** pages. Blank pages are indicated.



1 A motor car has many features that are similar to the characteristics of living things.

Which characteristic of living organisms **cannot** be matched to a feature of a car?

- A release of energy by breaking down energy-rich molecules
- B release of waste materials
- C reproduction of a similar version of itself
- D takes in materials for energy

2 The diagram shows a cell.

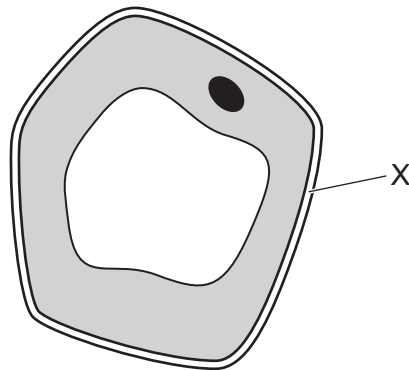

What is the function of X?

- A contains the genetic information
- B controls substances entering and leaving the cell
- C maintains the shape of the cell
- D photosynthesis

3 A sample of food contains only fat, protein and water.

Which food tests give a positive result when the sample is tested?

| | Benedict's solution | biuret solution | ethanol emulsion | iodine solution |
|----------|---------------------|-----------------|------------------|-----------------|
| A | ✓ | ✓ | x | x |
| B | ✓ | x | x | ✓ |
| C | x | ✓ | ✓ | x |
| D | x | ✓ | ✓ | ✓ |

- 4 The diagram shows how the activity of an enzyme changes with temperature.

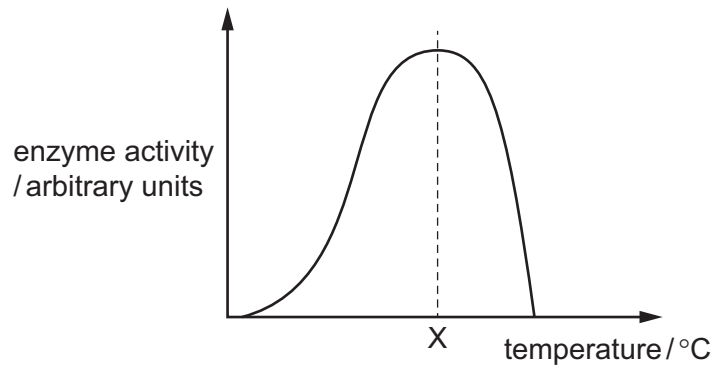

This enzyme works in the human body.

What is the most likely value of temperature X?

- A** 10°C **B** 40°C **C** 70°C **D** 100°C

- 5 What is necessary for photosynthesis?

- 1 carbon dioxide
- 2 chlorophyll
- 3 glucose
- 4 light
- 5 oxygen
- 6 water

- A** 1, 2, 4 and 6
B 1, 3, 4 and 6
C 2, 3, 4 and 5
D 3, 4, 5 and 6

- 6 Which breakdown processes occur inside cells, and which occur outside cells?

| | large molecules to small molecules for absorption | breakdown of glucose to release energy |
|----------|---|--|
| A | inside | inside |
| B | inside | outside |
| C | outside | inside |
| D | outside | outside |

7 Which statement about the pulmonary vein is correct?

- A It carries blood from the heart to the body.
- B It carries blood from the heart to the lungs.
- C It carries blood to the heart from the body.
- D It carries blood to the heart from the lungs.

8 Which statement about adrenaline is correct?

- A It is produced by a gland.
- B It is transported in the red blood cells.
- C It only has one target organ.
- D It reduces the size of the pupils.

9 Which row about whether roots and shoots respond to gravity is correct?

| | respond to gravity | |
|----------|--------------------|--------|
| | roots | shoots |
| A | no | no |
| B | no | yes |
| C | yes | no |
| D | yes | yes |

10 Which row describes asexual reproduction?

| | number of parents | a zygote is produced | offspring identical to the parent |
|----------|-------------------|----------------------|-----------------------------------|
| A | 1 | no | yes |
| B | 1 | yes | no |
| C | 2 | no | yes |
| D | 2 | yes | no |

11 Which conditions are needed for the germination of seeds?

- 1 oxygen
- 2 suitable temperature
- 3 water

A 1 and 2 only **B** 1 and 3 only **C** 2 and 3 only **D** 1, 2 and 3

12 The diagram shows a food web.

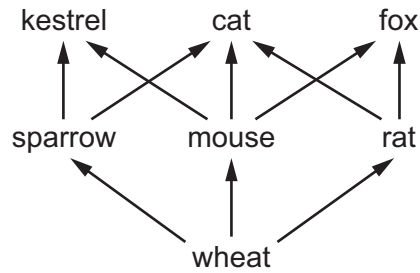

Which sentence correctly describes an organism in the food web?

- A** The cat is a herbivore and consumer.
- B** The kestrel is a carnivore and consumer.
- C** The mouse is a herbivore and producer.
- D** The sparrow is a carnivore and consumer.

13 The diagram shows part of the carbon cycle.

Which arrow represents respiration by decomposers?

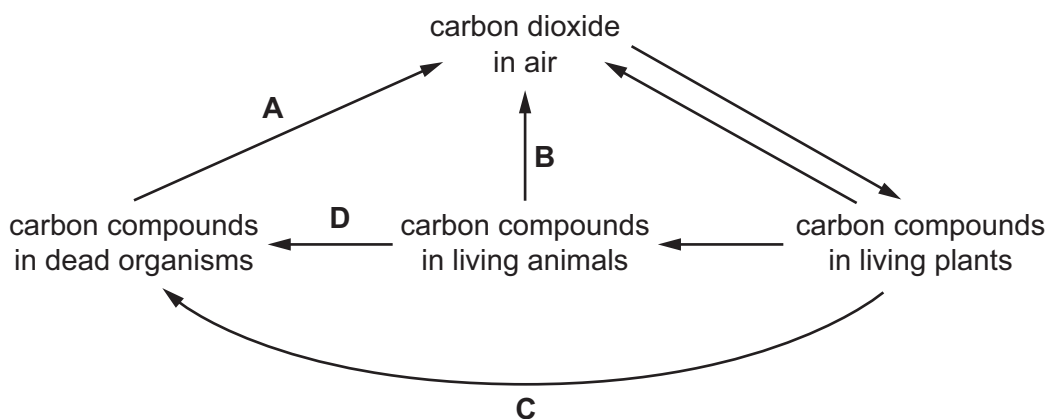

14 Which term describes ammonia, NH_3 ?

- A element
- B ion
- C atom
- D molecule

15 Chromatography separates ink into different colours.

Which diagram shows how the apparatus is set up?

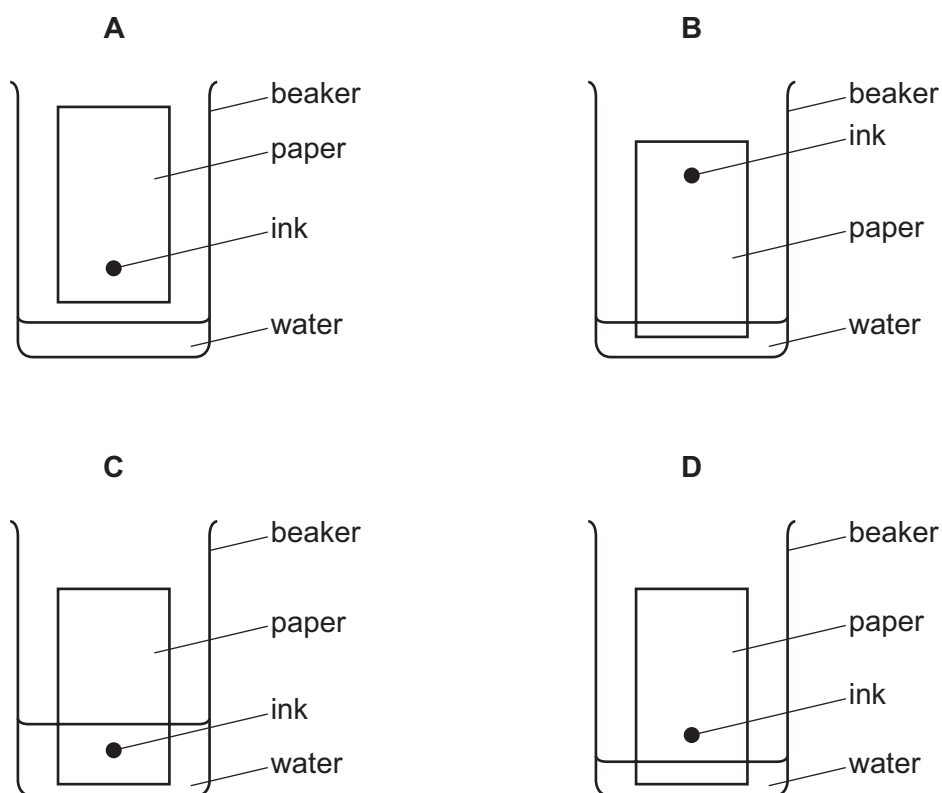

16 Sugar dissolves in water to form sugar solution.

Which word describes the sugar?

- A distillate
- B filtrate
- C solute
- D solvent

17 Which equation is balanced?

- A** $\text{Cu} + \text{O}_2 \rightarrow \text{CuO}$
B $2\text{CO} + \text{O}_2 \rightarrow 2\text{CO}_2$
C $2\text{Mg} + 2\text{HCl} \rightarrow \text{MgCl}_2 + \text{H}_2$
D $2\text{N}_2 + 3\text{H}_2 \rightarrow 2\text{NH}_3$

18 The diagram shows apparatus used for electrolysis.

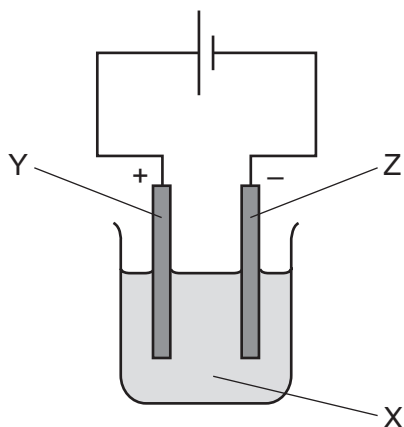

What are X, Y and Z?

| | X | Y | Z |
|----------|-------------|---------|---------|
| A | electrode | anode | cathode |
| B | electrode | cathode | anode |
| C | electrolyte | anode | cathode |
| D | electrolyte | cathode | anode |

19 Which temperature changes occur during exothermic and endothermic reactions?

| | exothermic | endothermic |
|----------|------------|-------------|
| A | decreases | increases |
| B | decreases | no change |
| C | increases | decreases |
| D | increases | no change |

20 Which line on the graph represents the reaction with the greatest rate?

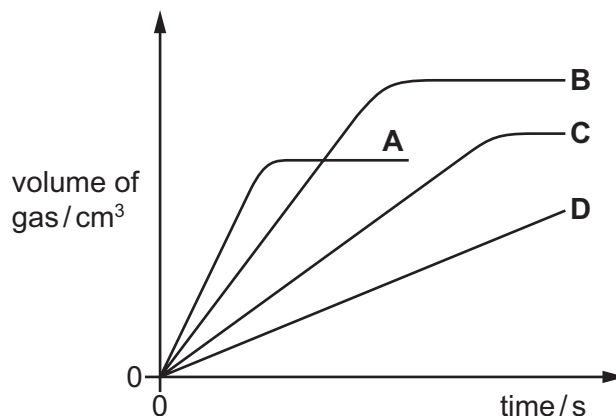

21 Which substances react with dilute sulfuric acid to make copper sulfate?

- 1 copper
- 2 copper carbonate
- 3 copper hydroxide
- 4 copper nitrate

A 1 and 2 **B** 1 and 4 **C** 2 and 3 **D** 3 and 4

22 Acid X reacts with metal Y.

A colourless gas is given off and a pale green solution is produced.

Two tests are carried out on the solution.

| test | reagent(s) added | result |
|------|--|-------------------|
| 1 | aqueous silver nitrate and nitric acid | white precipitate |
| 2 | aqueous sodium hydroxide | green precipitate |

What are acid X and metal Y?

| | acid | metal |
|----------|--------------|-------|
| A | hydrochloric | iron |
| B | hydrochloric | zinc |
| C | sulfuric | iron |
| D | sulfuric | zinc |

- 23 Which statement about the Periodic Table is **not** correct?
- A It lists all the known elements.
 - B Non-metallic elements are placed on the right-hand side.
 - C The position of an element helps us to predict its properties.
 - D Vertical columns in the Periodic Table are called periods.
- 24 Ammonia, NH_3 , can be made by combining the gases nitrogen, N_2 , and hydrogen, H_2 .
- This reaction is slow.
- When element Y is added, the rate of reaction increases.
- What is Y?
- A Al
 - B Fe
 - C Rb
 - D I_2
- 25 Which method is used to extract copper from copper(II) oxide?
- A dissolving copper(II) oxide in hydrochloric acid and then filtering
 - B dissolving copper(II) oxide in water and then filtering
 - C heating the copper(II) oxide
 - D heating the copper(II) oxide mixed with carbon
- 26 Which process does **not** produce carbon dioxide?
- A fractional distillation of petroleum
 - B the complete combustion of methane
 - C the reaction between an acid and a carbonate
 - D the thermal decomposition of calcium carbonate
- 27 Which statement describes a hydrocarbon?
- A a compound that burns to form carbon dioxide and hydrogen
 - B a compound that contains carbon and hydrogen only
 - C a compound that only contains ionic bonds
 - D a compound that reacts easily with metals

28 The diagram shows the speed–time graph for a car travelling along a horizontal road.

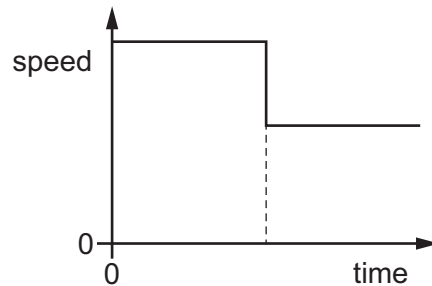

What is the distance–time graph for this part of the journey?

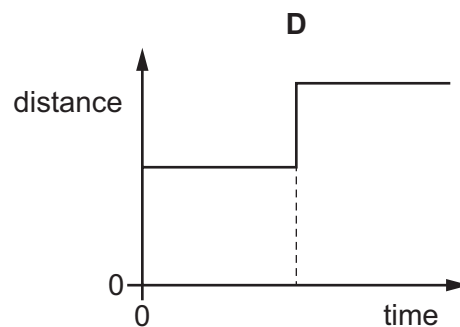
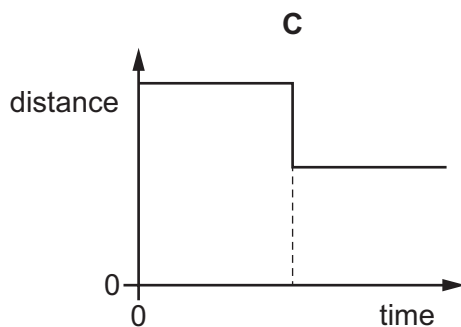
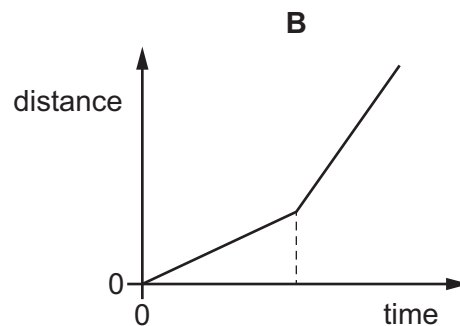
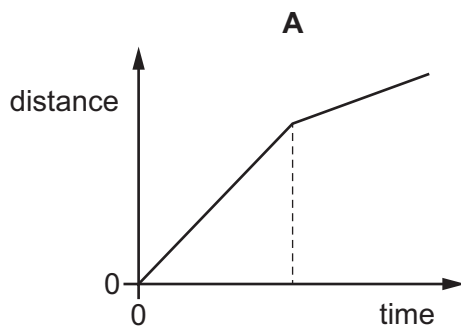

29 A solid metal cube of side 5.0 cm has a mass of 250 g.

What is the density of the metal?

- A** 0.50 g/cm^3 **B** 2.0 g/cm^3 **C** 10 g/cm^3 **D** 50 g/cm^3

30 A raindrop falls vertically at a constant speed.

What is the resultant force on the raindrop as it falls?

- A** It is equal to the air pressure on the drop.
B It is equal to the air resistance on the drop.
C It is equal to the weight of the drop.
D It is zero.

31 An object is not moving. Work is done on the object and it moves a known distance.

What other single measurement is needed to calculate the amount of work done?

- A** the acceleration of the object
- B** the direction of movement of the object
- C** the force applied to the object in the direction of movement
- D** the speed of the object

32 An apple falls to the ground.

Which form of energy decreases as the apple falls?

- A** chemical potential
- B** gravitational potential
- C** kinetic
- D** sound

33 What happens as a liquid starts to evaporate?

- A** The mass of the remaining liquid increases.
- B** The mass of the remaining liquid is constant.
- C** The temperature of the remaining liquid decreases.
- D** The temperature of the remaining liquid increases.

34 In which states of matter can convection occur?

| | in a solid | in a liquid | in a gas |
|----------|------------|-------------|----------|
| A | no | no | yes |
| B | no | yes | yes |
| C | yes | no | no |
| D | yes | yes | no |

35 The diagram shows a section of a rope.

Four wave crests pass a point on the rope every second.

Each wave crest travels 80 cm in one second.

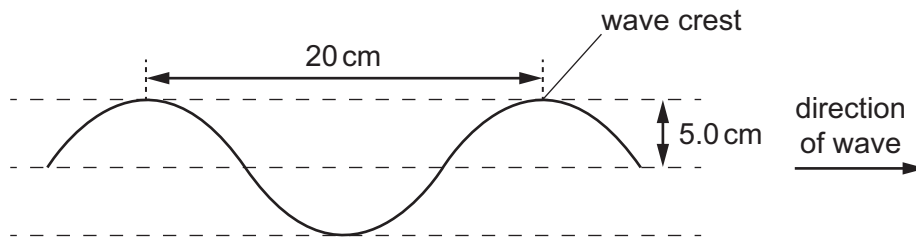

What is the speed of the wave?

- A 4.0 cm/s B 5.0 cm/s C 20 cm/s D 80 cm/s

36 A water wave strikes a plane barrier.

Which diagram shows the direction of travel of the reflected wave?

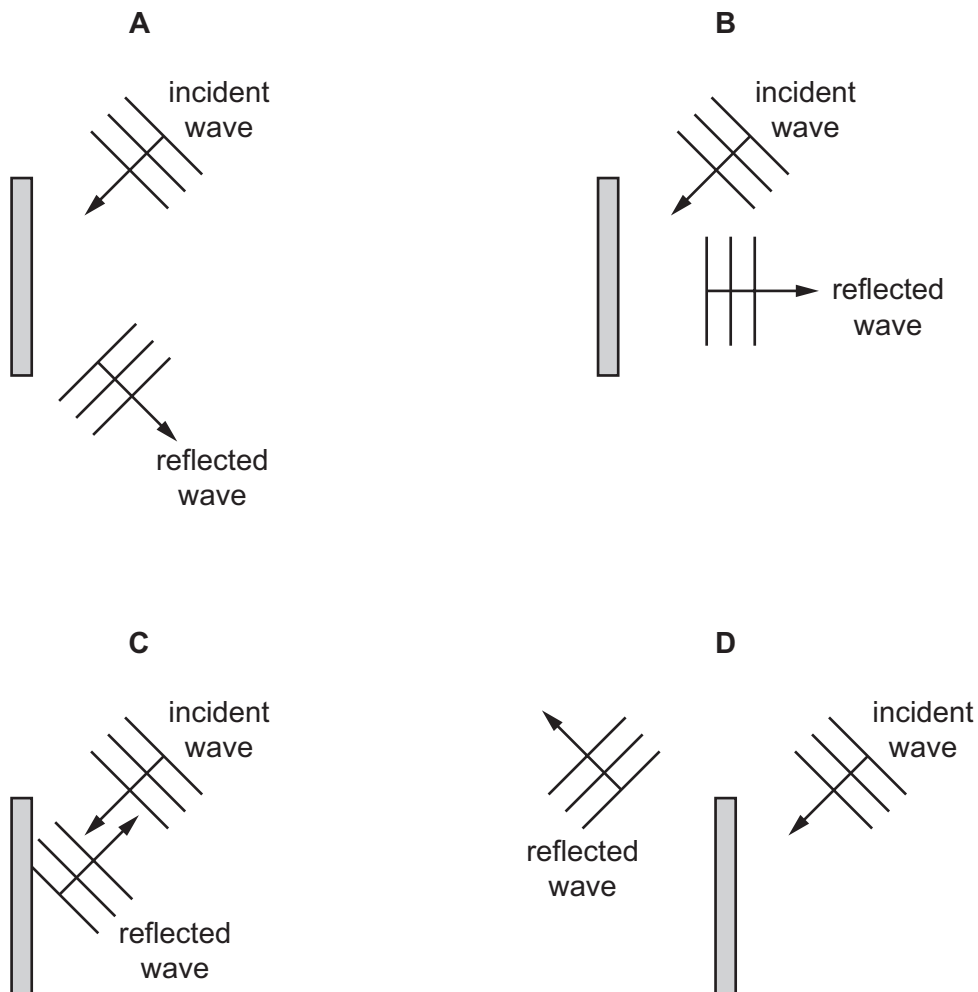

37 Which substance is an electrical insulator?

- A aluminium
- B copper
- C plastic
- D steel

38 A power supply causes a current in a circuit.

The electromotive force (e.m.f.) of the power supply and the resistance of the circuit are both changed.

Which pair of changes **must** result in a smaller current in the circuit?

| | e.m.f. | resistance |
|----------|-----------|------------|
| A | decreased | decreased |
| B | decreased | increased |
| C | increased | decreased |
| D | increased | increased |

39 The diagram shows a cell connected to a resistor and two meters, X and Y.

The circuit is used when determining the resistance of the resistor.

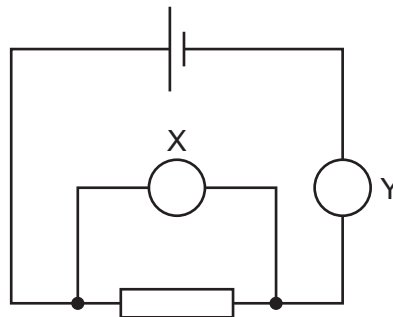

What are the quantities measured by meters X and Y, and what are their correct units?

| | meter X | | meter Y | |
|----------|----------|------|----------|------|
| | quantity | unit | quantity | unit |
| A | current | A | p.d. | V |
| B | current | V | p.d. | A |
| C | p.d. | A | current | V |
| D | p.d. | V | current | A |

40 The diagram shows a circuit containing a 2.0 V cell, a fuse and a resistor of resistance $4.0\ \Omega$.

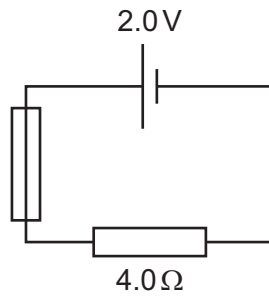

What is the most appropriate rating for the fuse?

- A** 0.4 A **B** 1 A **C** 2 A **D** 5 A

BLANK PAGE

Permission to reproduce items where third-party owned material protected by copyright is included has been sought and cleared where possible. Every reasonable effort has been made by the publisher (UCLES) to trace copyright holders, but if any items requiring clearance have unwittingly been included, the publisher will be pleased to make amends at the earliest possible opportunity.

To avoid the issue of disclosure of answer-related information to candidates, all copyright acknowledgements are reproduced online in the Cambridge Assessment International Education Copyright Acknowledgements Booklet. This is produced for each series of examinations and is freely available to download at www.cambridgeinternational.org after the live examination series.

Cambridge Assessment International Education is part of the Cambridge Assessment Group. Cambridge Assessment is the brand name of the University of Cambridge Local Examinations Syndicate (UCLES), which itself is a department of the University of Cambridge.

The Periodic Table of Elements

| Group | | | | | | | | | | | | | | | | | | | | | | | | | | | | | | | | | | | |
|-----------------------------------|------------------------------------|--|--|------------------------------------|-------------------------------------|-------------------------------------|-------------------------------------|-------------------------------------|---------------------------------------|--------------------------------------|--------------------------------------|-----------------------------------|------------------------------------|------------------------------------|--------------------------------------|-------------------------------------|-----------------------------------|-----------------------------------|----------------------------------|----------------------------------|------------------------------------|------------------------------------|-----------------------------------|-----------------------------------|----------------------------------|-----------------------------------|------------------------------------|--------------------------------|-----------------------------------|------------------------------------|--------------------------------|-----------------------------------|----------------------------------|----------------------------------|-------------------------------|
| I | II | III | | | | | | | | | | IV | V | VI | VII | VIII | | | | | | | | | | | | | | | | | | | |
| 3 Li lithium 7 | 4 Be beryllium 9 | <div style="border: 1px solid black; padding: 5px; width: fit-content; margin: 0 auto;"> Key atomic number atomic symbol name relative atomic mass </div> | | | | | | | | | | | | | | | | 2 He helium 4 | | | | | | | | | | | | | | | | | |
| 11 Na sodium 23 | 12 Mg magnesium 24 | 13 Al aluminium 27 | 14 Si silicon 28 | 15 P phosphorus 31 | 16 S sulfur 32 | 17 Cl chlorine 35.5 | 18 Ar argon 40 | 19 K potassium 39 | 20 Ca calcium 40 | 21 Sc scandium 45 | 22 Ti titanium 48 | 23 V vanadium 51 | 24 Cr chromium 52 | 25 Mn manganese 55 | 26 Fe iron 56 | 27 Co cobalt 59 | 28 Ni nickel 59 | 29 Cu copper 64 | 30 Zn zinc 65 | 31 Ga gallium 70 | 32 Ge germanium 73 | 33 As arsenic 75 | 34 Se selenium 79 | 35 Br bromine 80 | 36 Kr krypton 84 | | | | | | | | | | |
| 37 Rb rubidium 85 | 38 Sr strontium 88 | 39 Y yttrium 89 | 40 Zr zirconium 91 | 41 Nb niobium 93 | 42 Mo molybdenum 96 | 43 Tc technetium — | 44 Ru ruthenium 101 | 45 Rh rhodium 103 | 46 Pd palladium 106 | 47 Ag silver 108 | 48 Cd cadmium 112 | 49 In indium 115 | 50 Sn tin 119 | 51 Sb antimony 122 | 52 Te tellurium 128 | 53 I iodine 127 | 54 Xe xenon 131 | 55 Cs caesium 133 | 56 Ba barium 137 | 57–71 lanthanoids | 72 Hf hafnium 178 | 73 Ta tantalum 181 | 74 W tungsten 184 | 75 Re rhenium 186 | 76 Os osmium 190 | 77 Ir iridium 192 | 78 Pt platinum 195 | 79 Au gold 197 | 80 Hg mercury 201 | 81 Tl thallium 204 | 82 Pb lead 207 | 83 Bi bismuth 209 | 84 Po polonium — | 85 At astatine — | 86 Rn radon — |
| 87 Fr francium — | 88 Ra radium — | 89–103 actinoids | 104 Rf rutherfordium — | 105 Db dubnium — | 106 Sg seaborgium — | 107 Bh bohrium — | 108 Hs hassium — | 109 Mt meitnerium — | 110 Ds darmstadtium — | 111 Rg roentgenium — | 112 Cn copernicium — | 113 Nh nihonium — | 114 Fl flerovium — | 115 Mc moscovium — | 116 Lv livermorium — | 117 Ts tennessine — | 118 Og oganeson — | | | | | | | | | | | | | | | | | | |

| | | | | | | | | | | | | | | |
|-------------------------------------|-----------------------------------|--|-------------------------------------|------------------------------------|------------------------------------|------------------------------------|--------------------------------------|-----------------------------------|--------------------------------------|-------------------------------------|----------------------------------|--------------------------------------|-------------------------------------|-------------------------------------|
| 57 La lanthanum 139 | 58 Ce cerium 140 | 59 Pr praseodymium 141 | 60 Nd neodymium 144 | 61 Pm promethium — | 62 Sm samarium 150 | 63 Eu europium 152 | 64 Gd gadolinium 157 | 65 Tb terbium 159 | 66 Dy dysprosium 163 | 67 Ho holmium 165 | 68 Er erbium 167 | 69 Tm thulium 169 | 70 Yb ytterbium 173 | 71 Lu lutetium 175 |
| 89 Ac actinium — | 90 Th thorium 232 | 91 Pa protactinium 231 | 92 U uranium 238 | 93 Np neptunium — | 94 Pu plutonium — | 95 Am americium — | 96 Cm curium — | 97 Bk berkelium — | 98 Cf californium — | 99 Es einsteinium — | 100 Fm fermium — | 101 Md mendelevium — | 102 No nobelium — | 103 Lr lawrencium — |

lanthanoids

actinoids

The volume of one mole of any gas is 24 dm³ at room temperature and pressure (r.t.p.).