



**Cambridge Assessment International Education**  
Cambridge International General Certificate of Secondary Education

CANDIDATE  
NAME

CENTRE  
NUMBER

--	--	--	--	--

CANDIDATE  
NUMBER

--	--	--	--



**COMBINED SCIENCE**

**0653/63**

Paper 6 Alternative to Practical

**October/November 2019**

**1 hour**

Candidates answer on the Question Paper.

No Additional Materials are required.

**READ THESE INSTRUCTIONS FIRST**

Write your centre number, candidate number and name on all the work you hand in.

Write in dark blue or black pen.

You may use an HB pencil for any diagrams or graphs.

Do not use staples, paper clips, glue or correction fluid.

**DO NOT WRITE IN ANY BARCODES.**

Answer **all** questions.

Electronic calculators may be used.

You may lose marks if you do not show your working or if you do not use appropriate units.

At the end of the examination, fasten all your work securely together.

The number of marks is given in brackets [ ] at the end of each question or part question.

This document consists of **14** printed pages and **2** blank pages.

- 1 (a) A student investigates the movement of water in potato cylinders.

Water moves from an area of lower sugar concentration to an area of higher sugar concentration.

The unit of concentration is  $\text{mol}/\text{dm}^3$ .

He cuts six potato cylinders, each one 60 mm long and with a diameter of 10 mm.

He places two potato cylinders, **A** and **B**, into a test-tube and adds  $0.1 \text{ mol}/\text{dm}^3$  sugar solution so that both cylinders are completely covered.

He repeats this using  $0.3 \text{ mol}/\text{dm}^3$  and  $0.5 \text{ mol}/\text{dm}^3$  sugar solution as shown in Fig. 1.1.

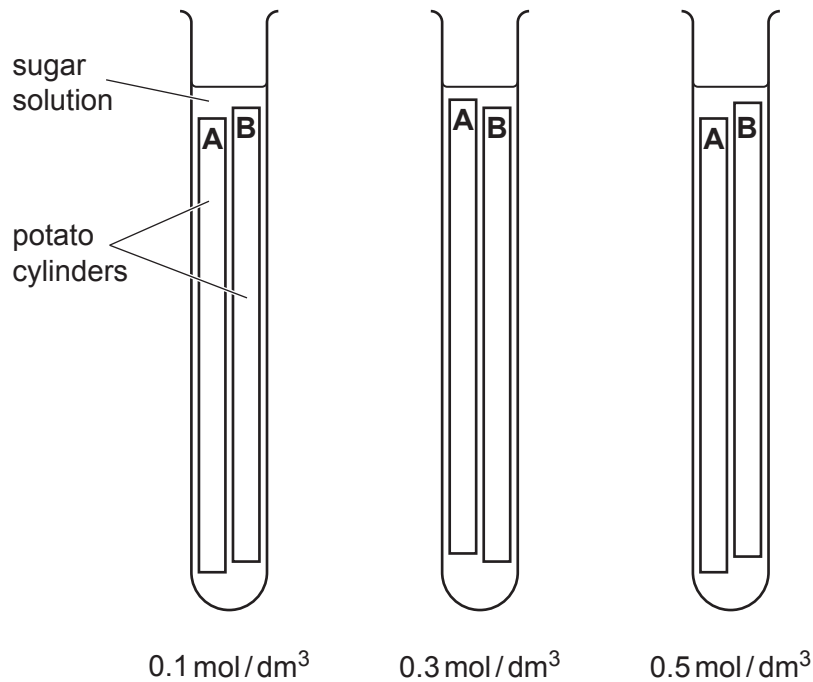

**Fig. 1.1**

He leaves the potato cylinders in the sugar solutions for 12 hours.

After 12 hours he removes the potato cylinders and dries them with a paper towel.

The final lengths of the potato cylinders after 12 hours are shown in Fig. 1.2.

0.1 mol/dm<sup>3</sup> sugar solution0.3 mol/dm<sup>3</sup> sugar solution0.5 mol/dm<sup>3</sup> sugar solution

Fig. 1.2

- (i) Explain why it is important that the potato cylinders are completely covered with the sugar solution.

.....  
 ..... [1]

- (ii) On Fig. 1.2, measure the final lengths of the two cylinders from the **0.5 mol/dm<sup>3</sup>** sugar solution.

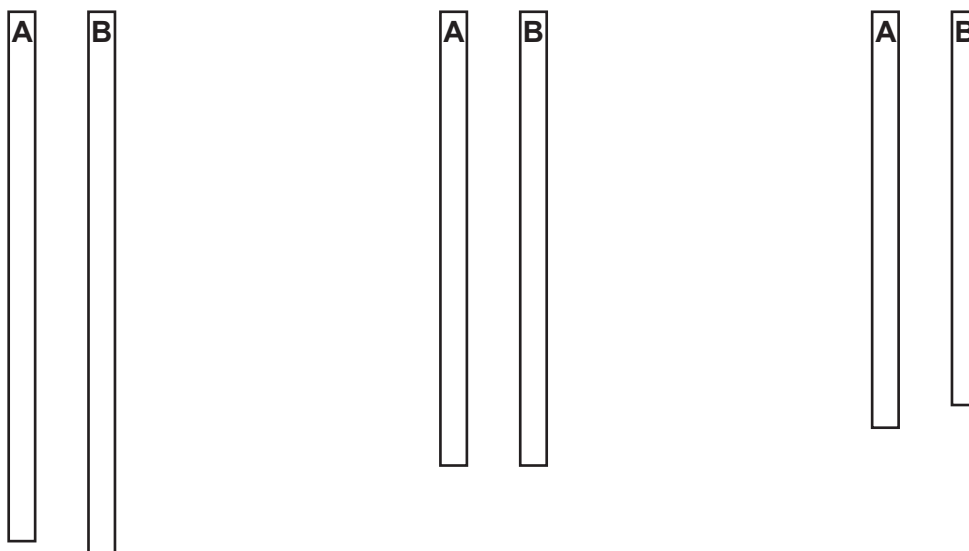
Record these final lengths in Table 1.1.

[1]

Table 1.1

concentration of sugar solution mol/dm <sup>3</sup>	potato cylinder	initial length /mm	final length /mm	change in length /mm	average change in length /mm
0.1	<b>A</b>	60	70	+10	+11
	<b>B</b>	60	72	+12	
0.3	<b>A</b>	60	60	0	0
	<b>B</b>	60	60	0	
0.5	<b>A</b>	60			
	<b>B</b>	60			

- (iii) Calculate the change in length for the potato cylinders in 0.5 mol/dm<sup>3</sup> sugar solution. Include a plus (+) or a minus (–) sign as appropriate.

Record this value in Table 1.1.

[1]

- (iv) Calculate the average change in length for the potato cylinders in 0.5 mol/dm<sup>3</sup> sugar solution. Include a plus (+) or a minus (–) sign as appropriate.

Record this value in Table 1.1.

[1]

- (v) Calculate the average **percentage** change in length of the potato cylinders in 0.1 mol/dm<sup>3</sup> sugar solution.

Use the equation shown:

$$\text{average percentage change in length} = \frac{\text{average change in length}}{\text{initial length}} \times 100$$

average percentage change = .....% [1]

- (b) (i) Explain why the potato cylinders increased in length in the 0.1 mol/dm<sup>3</sup> sugar solution.

.....  
 ..... [1]

- (ii) Explain why there were no changes in length of potato cylinders in the 0.3 mol/dm<sup>3</sup> sugar solution.

.....  
 ..... [1]

- (c) The student repeats the investigation but places two 60 mm long potato cylinders into a sugar solution of unknown concentration for 12 hours. He calculates the average change in length.

The results are shown in Table 1.2.

**Table 1.2**

concentration of sugar solution / mol/dm <sup>3</sup>	potato cylinder	initial length /mm	final length /mm	change in length /mm	average change in length /mm
unknown	<b>A</b>	60	62	+2	+3
	<b>B</b>	60	64	+4	

- (i) Use the results in Table 1.1 and Table 1.2 to suggest the concentration of the sugar solution of unknown concentration.

concentration of sugar solution = .....mol/dm<sup>3</sup> [1]

- (ii) The student states that to be able to predict the unknown concentration of the sugar solution, all other factors should be kept the same when the investigation is repeated.

Suggest **three** factors that should be kept the same.

- 1. ....  
.....
- 2. ....  
.....
- 3. ....  
.....

[3]

- (d) Describe how the potato cylinder can be tested for the presence of starch.

Include the result for a positive test and the result for a negative test.

- test .....
- .....
- positive result .....
- negative result .....

[2]

[Total: 13]

2 A student has samples of two grey solids **E** and **F**.

Solid **E** is covered in oil and kept in a bottle with the top screwed on.

Solid **F** is in a bottle with the label 'Do not touch with bare hands'.

(a) The student adds a small piece of **E** to cold water in a large beaker.

The solid skates around the surface of the water, fizzes violently and forms solution **G**.

She tests the gas and concludes that it is hydrogen.

(i) Describe the test which confirms the gas is hydrogen and give the result for a positive test.

test .....

positive result .....

[1]

(ii) She puts some of solution **G** into a test-tube and adds aqueous iron(II) nitrate. A green precipitate is formed.

Suggest the identity of solution **G** and solid **E**.

**G** is .....

**E** is .....

[1]

(iii) Suggest an alternative reagent to iron(II) nitrate for identifying solution **G** in (a)(ii).

.....

..... [1]

(b) She adds a small piece of solid **F** to cold water in a large beaker.

The solid moves up and down in the water, fizzes vigorously and forms solution **H**.

The gas given off is hydrogen.

She puts some of solution **H** into a test-tube.

She places marble chips in a separate test-tube, adds hydrochloric acid and bubbles the gas formed into solution **H**.

Solution **H** goes milky.

(i) Draw a diagram of the assembled apparatus used to bubble the gas formed into solution **H**. Label the apparatus and the chemicals.

[2]

(ii) Suggest the identity of solution **H**.

..... [1]

(iii) Suggest the identity of solid **F**.

..... [1]

[Total: 7]

3 Hydrogen peroxide is used to bleach hair. Hydrogen peroxide slowly decomposes giving off oxygen gas.

When a catalyst is added to hydrogen peroxide, oxygen gas is given off more quickly.

Plan an experiment to find out which one of the three solid oxides, manganese dioxide, copper oxide and zinc oxide, is the best catalyst for this reaction.

You may use any common laboratory apparatus and samples of hydrogen peroxide, manganese dioxide, copper oxide and zinc oxide.

Include in your answer:

- the apparatus needed, including a labelled diagram if you wish
- a brief description of the method, including any safety precautions and why these are needed
- the measurements you will make
- what you will control
- how you will process your results
- how you will use your results to draw a conclusion.

.....

.....

.....

.....

.....

.....

.....





**BLANK PAGE**

- 4 A student investigates how the size of the average force needed to move a door varies with its distance  $d$  from the hinge (pivot).

Fig. 4.1 shows the apparatus used in the investigation.

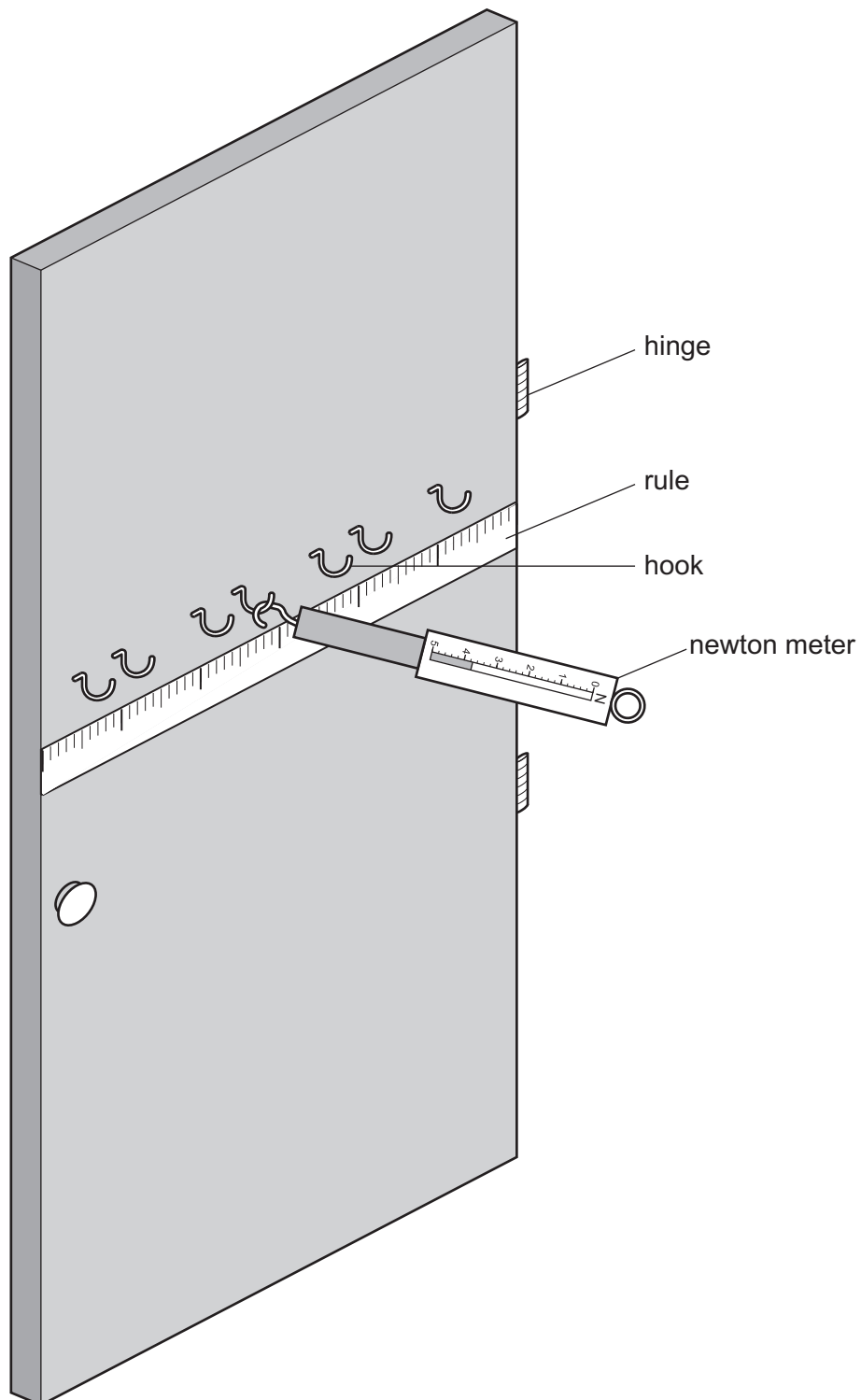

Fig. 4.1

- A newton meter is attached to the hook at distance  $d = 0.10$  m from the hinge.
- The newton meter is pulled horizontally at right angles to the door until the door moves.
- The student measures the force needed to move the door.
- She repeats this measurement twice more.
- She then repeats this procedure using hooks at the distances shown in Table 4.1.
- Her results are recorded in Table 4.1.

**Table 4.1**

distance $d$ from hinge/m	force $F$ required to move the door/N			average force to move door/N
	experiment 1	experiment 2	experiment 3	
0.10	4.20	4.35	4.25	4.27
0.20	2.40	2.50	2.00	2.30
0.25	1.80	1.75	1.90	1.82
	1.20	1.80	1.45	1.48
0.40	0.95	1.05	1.20	1.07
0.50	0.80	0.75	0.75	
0.55	0.65	0.75	0.70	0.70

(a) Read the distance  $d$  from the hinge to the hook shown in Fig. 4.2.

Record this value in Table 4.1.

[1]

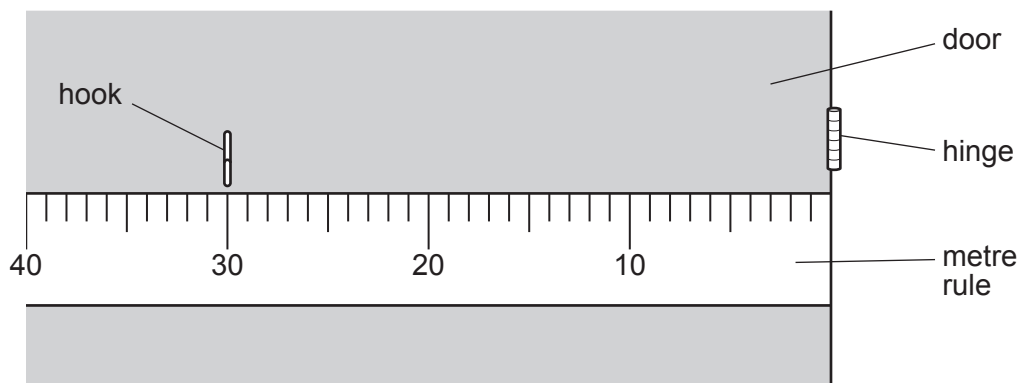
**Fig. 4.2**

- (b) Calculate the average force  $F$  needed to move the door when the newton meter is at a distance  $d = 0.50$  m from the hinge.

Record this value in Table 4.1.

[2]

- (c) (i) Plot a graph of the average force  $F$  needed to move the door (vertical axis) against the distance  $d$  from the hinge (pivot).

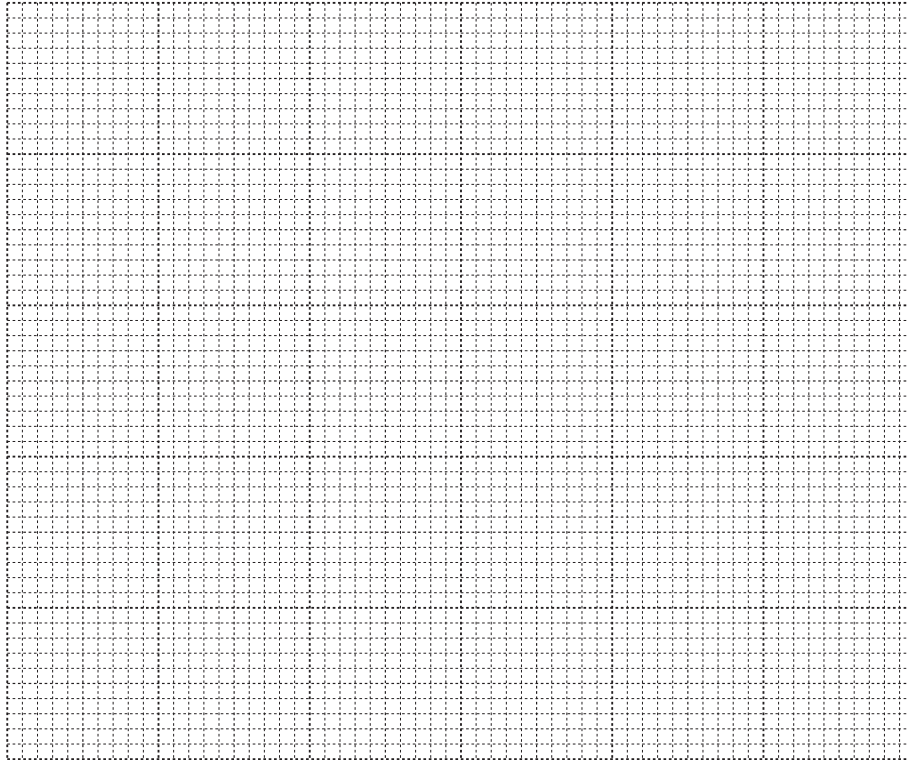

[3]

- (ii) Draw the best-fit smooth curve.

[1]

- (d) Describe in detail the relationship between the average force  $F$  needed to move the door and the distance  $d$ .

.....  
 .....

[2]

- (e) (i) Fig. 4.3 shows three different newton meters, **A**, **B** and **C**.

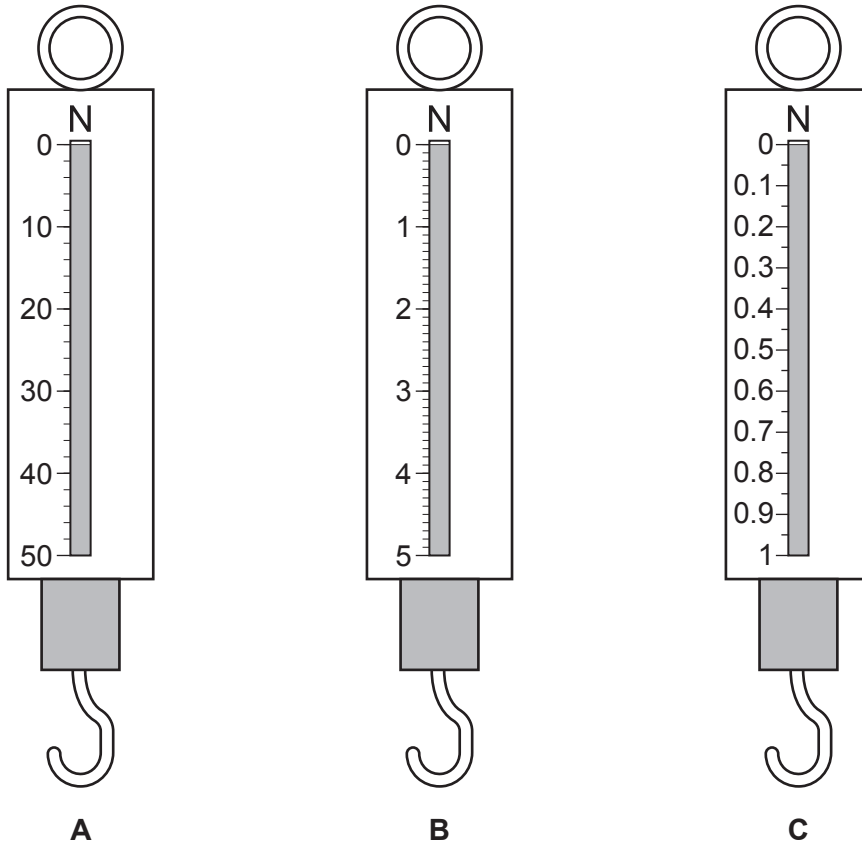

Fig. 4.3

The student uses newton meter **B** in her experiment.

Explain why **B** is more suitable than each of the other newton meters shown in Fig. 4.3.

.....  
 .....

[2]

- (ii) Draw a line on newton meter **B** in Fig. 4.3 to show the reading for distance  $d = 0.25$  m in experiment 1.

[1]

(f) Suggest **one** practical difficulty that the student has in getting accurate results for the investigation.

.....

..... [1]

[Total: 13]

**BLANK PAGE**

---

Permission to reproduce items where third-party owned material protected by copyright is included has been sought and cleared where possible. Every reasonable effort has been made by the publisher (UCLES) to trace copyright holders, but if any items requiring clearance have unwittingly been included, the publisher will be pleased to make amends at the earliest possible opportunity.

To avoid the issue of disclosure of answer-related information to candidates, all copyright acknowledgements are reproduced online in the Cambridge Assessment International Education Copyright Acknowledgements Booklet. This is produced for each series of examinations and is freely available to download at [www.cambridgeinternational.org](http://www.cambridgeinternational.org) after the live examination series.

Cambridge Assessment International Education is part of the Cambridge Assessment Group. Cambridge Assessment is the brand name of the University of Cambridge Local Examinations Syndicate (UCLES), which itself is a department of the University of Cambridge.