



**Cambridge Assessment International Education**  
Cambridge International General Certificate of Secondary Education

CANDIDATE  
NAME

--

CENTRE  
NUMBER

--	--	--	--	--

CANDIDATE  
NUMBER

--	--	--	--



**COMBINED SCIENCE**

**0653/41**

Paper 4 (Extended)

**October/November 2019**

**1 hour 15 minutes**

Candidates answer on the Question Paper.

No Additional Materials are required.

**READ THESE INSTRUCTIONS FIRST**

Write your centre number, candidate number and name on all the work you hand in.

Write in dark blue or black pen.

You may use an HB pencil for any diagrams or graphs.

Do not use staples, paper clips, glue or correction fluid.

**DO NOT WRITE IN ANY BARCODES.**

Answer **all** questions.

Electronic calculators may be used.

You may lose marks if you do not show your working or if you do not use appropriate units.

A copy of the Periodic Table is printed on page 20.

At the end of the examination, fasten all your work securely together.

The number of marks is given in brackets [ ] at the end of each question or part question.

This document consists of **19** printed pages and **1** blank page.

1 Fig. 1.1 shows some cells. The diagrams are not to scale.

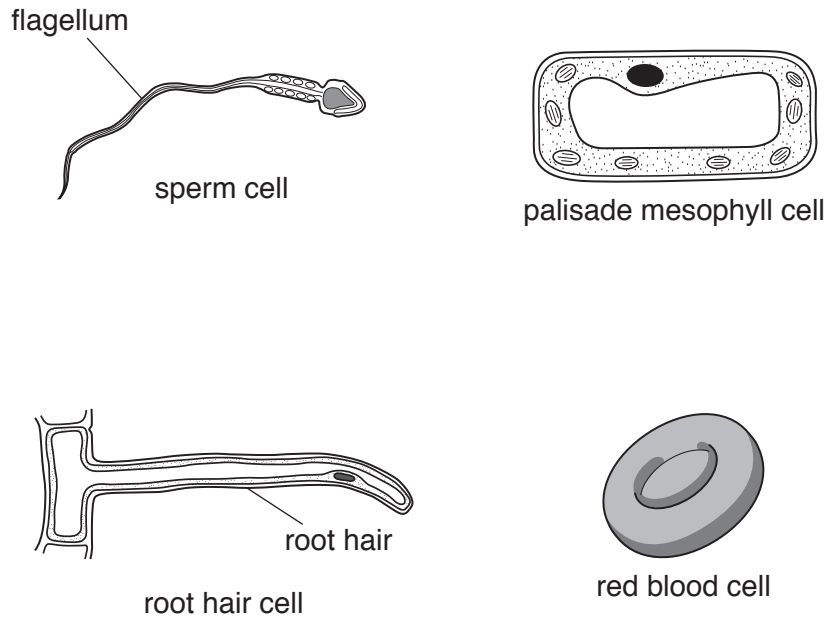

Fig. 1.1

(a) On Fig. 1.1 use label lines to name **two** structures in the palisade mesophyll cell which are absent from the red blood cell. [2]

(b) Describe the function of the root hair shown in Fig. 1.1.

.....  
..... [1]

(c) (i) The flagellum is one of the adaptive features of a sperm cell.

Suggest the function of the flagellum.

.....  
..... [1]

(ii) State **one other** adaptive feature of a sperm cell.

.....  
..... [1]

(d) Fig. 1.2 is a diagram of some body cells surrounded by capillaries.

Substances in the blood can reach the body cells by moving out of the capillaries.

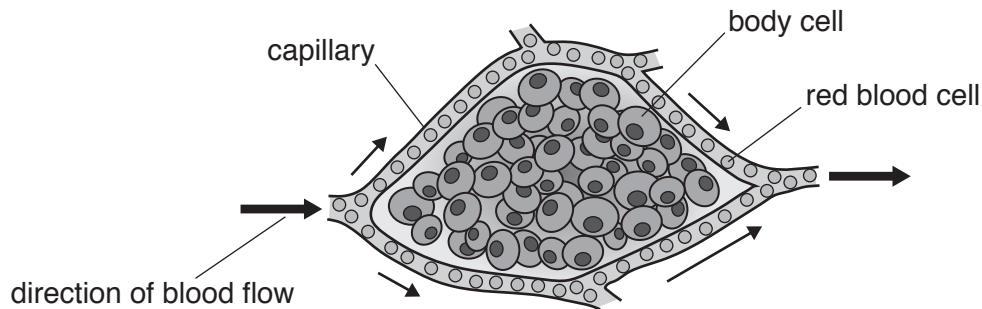

Fig. 1.2

(i) Circle **one** substance in the list that leaves the capillaries to enter the body cells.

- amylase      carbon dioxide      glucose      glycogen      starch**

[1]

(ii) Use words or phrases from the list to complete the following sentences about oxygen in the blood.

Each word or phrase may be used once, more than once or not at all.

- diffusion      dissolving      fat      haemoglobin      osmosis**  
**platelets      red blood cells      white blood cells**

Oxygen is carried in the blood by the ..... molecules  
 which are contained in the .....

Oxygen moves out of the capillary by the process of ..... [3]

(iii) Describe how the structure of capillaries enables some substances to pass through their walls.

..... [1]

[Total: 10]

**BLANK PAGE**

2 Hydrocarbons are composed of the two elements carbon and hydrogen.

(a) State the type of chemical bond that forms between these two elements.

Explain your answer.

type of chemical bond .....

explanation .....

.....

.....

[2]

(b) Cracking is a process used to make smaller alkene molecules from larger alkane molecules.

(i) State **two** reaction conditions needed for cracking hydrocarbons.

1. ....

2. ....

[2]

(ii) During cracking, one molecule of decane,  $C_{10}H_{22}$ , breaks down to form one molecule of ethane,  $C_2H_6$ , and four molecules of another hydrocarbon.

Complete the balanced symbol equation for the cracking of decane.



(c) During the complete combustion of hydrocarbons, carbon dioxide and water are produced.

(i) Draw a dot-and-cross diagram to show all of the outer shell electrons in the atoms in one molecule of carbon dioxide.

[2]

(ii) State **one** effect of an increase in the amount of carbon dioxide in the atmosphere.

.....

..... [1]

[Total: 8]

3 Fig. 3.1 shows how a small hydroelectric power station is used to supply electricity.

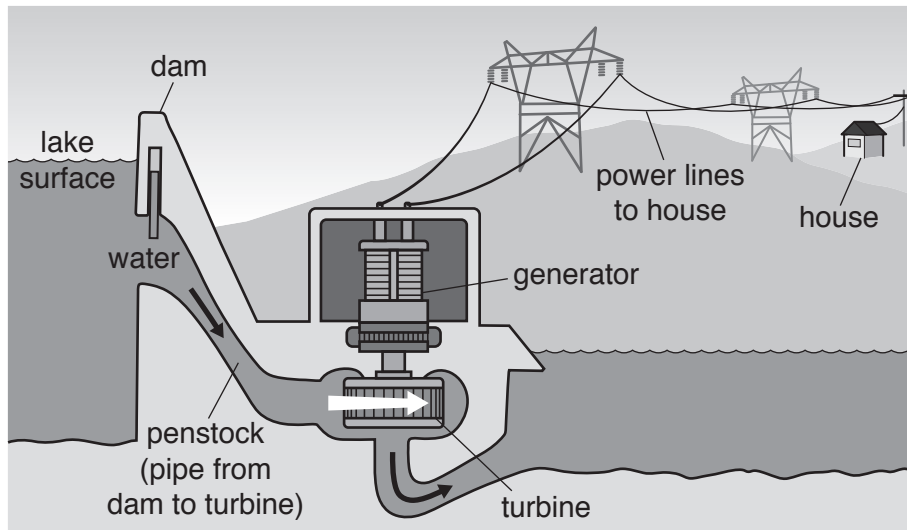

Fig. 3.1

(a) The flowing water turns the turbine which then turns the generator.

Identify, using the names on Fig. 3.1:

(i) **one** place where the gravitational potential energy of the water is at a maximum

..... [1]

(ii) **two** places where kinetic energy is part of the sequence of energy transfers.

..... and ..... [1]

(b) Hydroelectric power is an example of a renewable source of energy.

State **one** advantage and **one** disadvantage of hydroelectric power in terms of its environmental impact.

advantage .....

.....

disadvantage .....

.....

[2]

(c) In a house, electricity is used to power a television set.

An aerial for the television set receives signals in the radio wave region of the electromagnetic spectrum with a frequency of  $600 \times 10^6 \text{ Hz}$  (600 MHz).

(i) State the speed at which these signals travel.

..... [1]

(ii) Use your answer to (i) to calculate the wavelength of the signal.

Show your working.

wavelength = ..... m [2]

(iii) Fig. 3.2 shows the electromagnetic spectrum.

gamma radiation	X-rays	ultraviolet	visible light	infrared	microwaves	radio waves
-----------------	--------	-------------	---------------	----------	------------	-------------

**Fig. 3.2**

State the part of the electromagnetic spectrum used in television transmissions from satellites.

..... [1]

(d) The television set emits sound waves.

Describe how sound waves are transmitted in air.

You may wish to draw a diagram as part of your answer.

.....  
.....  
.....

[2]

[Total: 10]

4 (a) Plants make glucose by the process of photosynthesis.

Complete the balanced symbol equation for photosynthesis.



(ii) State **two** uses of the glucose made by photosynthesis.

1. ....
  2. ....
- [2]

(b) Fig. 4.1 shows a diagram of the cross-section of a leaf. The letters refer to the layers of cells in the leaf.

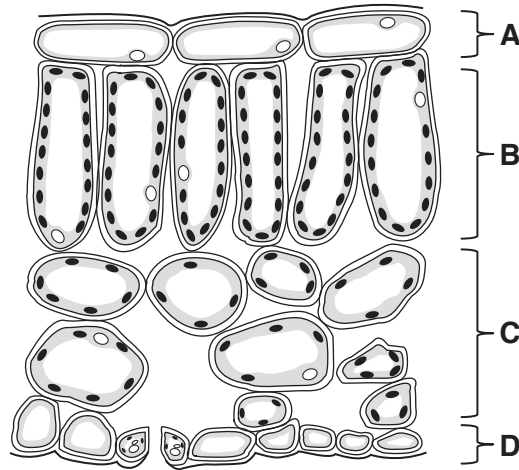

Fig. 4.1

(i) State the **letter** of the layer of the leaf where the greatest amount of photosynthesis takes place.

..... [1]

(ii) Explain your answer to (i).

.....

.....

..... [2]



(c) During transpiration water vapour is lost from leaves through the stomata.

When the air surrounding the leaves becomes more humid, the rate of transpiration decreases.

Explain why the rate of transpiration decreases.

.....

.....

..... [2]

[Total: 9]

- 5 (a) Aluminium is a Group III metal. It is **not** a transition metal.

Copper is a transition metal. It forms coloured compounds.

State **one other** property of copper that is not a property of aluminium.

..... [1]

- (b) Fig. 5.1 shows the apparatus used to extract copper from aqueous copper(II) chloride by electrolysis.

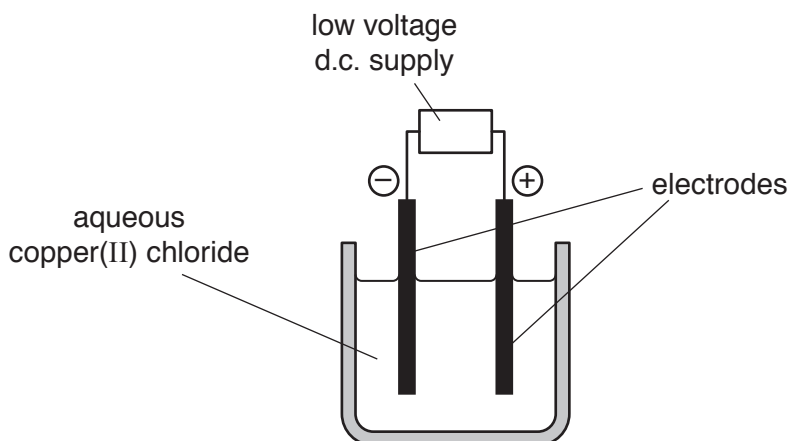

Fig. 5.1

- (i) During this process copper forms at the negative electrode.

State the name of the negative electrode.

..... [1]

- (ii) Explain how copper(II) ions change into copper atoms.

..... [2]

- (c) Copper is also extracted by heating copper oxide with carbon.

The word equation for the reaction is:



- (i) Name the reducing agent in this redox reaction.

..... [1]

(ii) Explain why aluminium **cannot** be extracted from aluminium oxide by heating with carbon.

.....  
..... [1]

(d) At a water treatment works, a scientist thinks that the water is contaminated with a soluble copper compound containing copper(II) ions.

Describe a test that is used to detect the presence of aqueous copper(II) ions.

Give the positive result for this test.

test .....

.....

result .....

.....

[2]

[Total: 8]

6 Table 6.1 gives some data about the planets Earth, Mars, Mercury and Venus.

**Table 6.1**

	Earth	Mars	Mercury	Venus
mass	$5.97 \times 10^{24}$ kg	$6.42 \times 10^{23}$ kg	$3.29 \times 10^{23}$ kg	$4.87 \times 10^{24}$ kg
volume	$1.08 \times 10^{21}$ m <sup>3</sup>	$1.63 \times 10^{20}$ m <sup>3</sup>	$6.08 \times 10^{19}$ m <sup>3</sup>	$9.28 \times 10^{20}$ m <sup>3</sup>
gravitational field strength $g$	9.81 N/kg	3.71 N/kg	3.70 N/kg	8.87 N/kg
mean temperature at surface	15 °C	-63 °C	167 °C	462 °C
pressure of atmosphere	101 000 N/m <sup>2</sup>	600 N/m <sup>2</sup>	0	9 300 000 N/m <sup>2</sup>
percentage of Sun's radiation reflected	31%	25%	7%	69%

(a) Use data from Table 6.1 to state which planet has the greatest volume.

..... [1]

(b) Use data from Table 6.1 to calculate the density of Mercury.

Show your working and give the units of your answer.

density = ..... units ..... [3]

(c) A mass of 5 kg is placed on each planet, 10 m above the planet's surface.

State on which planet this mass has the greatest gravitational potential energy.

Give a reason for your answer.

planet .....

reason .....

..... [2]

- (d) The surface of a planet reflects a percentage of the Sun’s radiation back into space. The rest of the radiation is absorbed by the planet.

Suggest **one** reason why the percentage of the Sun’s radiation reflected by the surface of Mercury is so low.

..... [1]

- (e) A space probe of mass 50kg descends through the atmosphere on Venus. The probe is slowed down by the atmosphere much more than it would be by the resistance of the Earth’s atmosphere.

Use data from Table 6.1 to explain this in terms of difference in the arrangement of the molecules in the atmosphere.

.....  
.....  
.....  
..... [2]

[Total: 9]

7 Fig. 7.1 shows the flow of energy through a forest ecosystem.

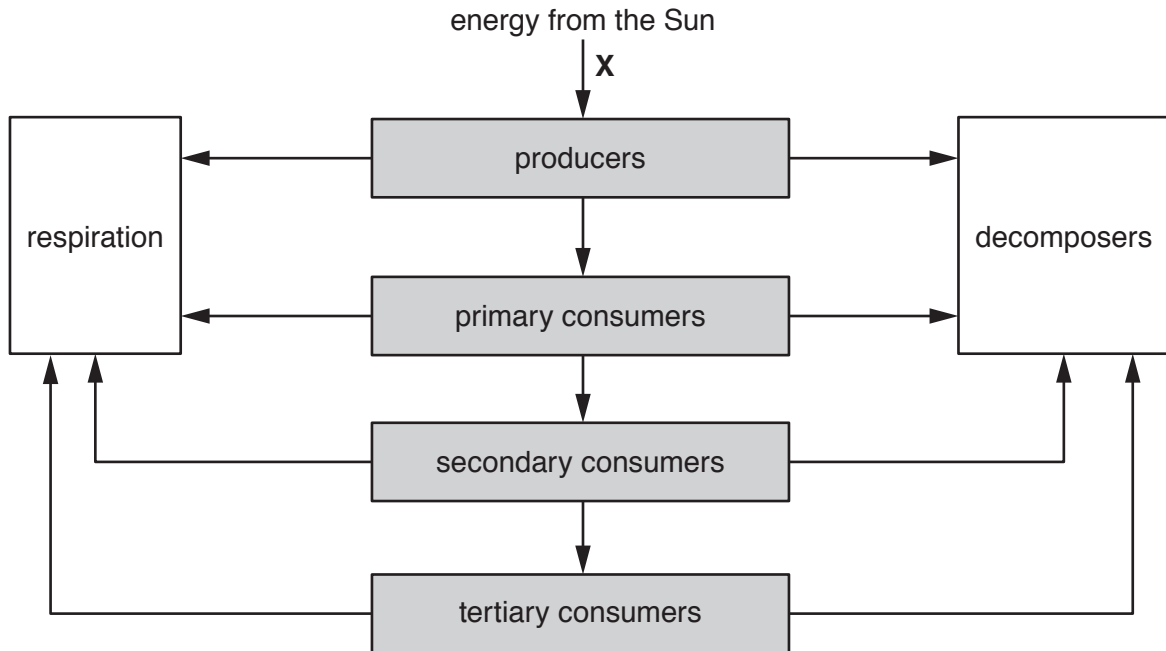

Fig. 7.1

(a) (i) Define the term *ecosystem*.

.....  
 .....  
 ..... [2]

(ii) Complete the sentence about the energy transfer at X.

At X ..... energy is transferred to  
 ..... energy. [2]

(b) The shaded boxes in Fig. 7.1 show the trophic levels in the ecosystem.

Energy is lost from the organisms at each trophic level.

State **two** ways in which energy is lost from the organisms at each trophic level.

1. ....  
 .....  
 2. ....  
 .....

[2]

- (c) The trees are the main producers in the forest. They are cut down and taken away from the ecosystem.

Suggest what happens to the primary consumers in the forest.

Explain your answer.

.....

.....

..... [2]

[Total: 8]

8 Table 8.1 shows data about Group I metals.

The data for rubidium is missing.

**Table 8.1**

element	melting point/°C	rate of reaction with water
lithium	181	slow
sodium	98	moderate
potassium	64	fast
rubidium		
caesium	29	very violent

(a) (i) Suggest the melting point of rubidium.

..... °C [1]

(ii) Predict the rate of reaction of rubidium with water.

..... [1]

(b) Rubidium reacts with water to form rubidium hydroxide solution and hydrogen.

(i) Suggest the formula of rubidium hydroxide.

..... [1]

(ii) Suggest the pH of rubidium hydroxide solution.

Explain your answer.

pH .....

explanation .....

..... [2]



(c) Rubidium hydroxide has a higher melting point than water.

Explain the difference in the melting point of rubidium hydroxide and of water.

In your answer refer to the type of bonds and the attractive forces.

.....  
.....  
.....  
.....  
.....  
..... [3]

(d) The reaction between rubidium and water is exothermic.

Describe what happens during an exothermic reaction. Use ideas about chemical energy and thermal energy in your answer.

.....  
.....  
.....  
..... [2]

[Total: 10]

9 (a) Fig. 9.1 shows a circuit containing three resistors,  $R_1$ ,  $R_2$  and  $R_3$ .

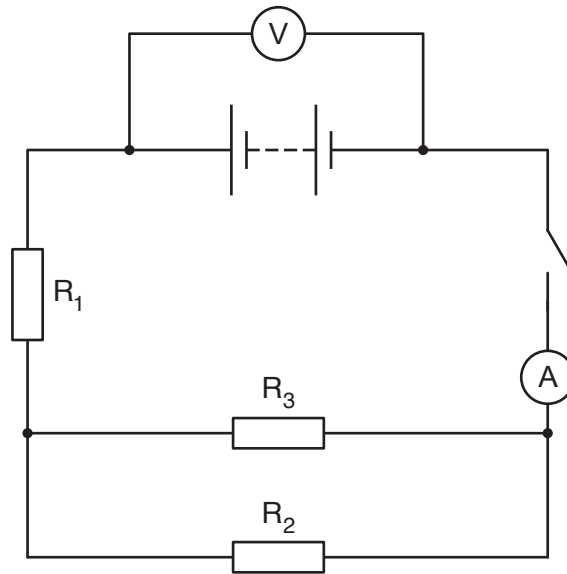

Fig. 9.1

(i)  $R_1$  has a value of  $8.0\ \Omega$ .

$R_2$  has a value of  $3.0\ \Omega$ .

$R_3$  has a value of  $6.0\ \Omega$ .

Complete steps 1 and 2 to calculate the value of the combined resistance of the three resistors in this circuit.

Show your working.

Step 1: Calculate the combined resistance of  $R_2$  and  $R_3$ .

combined resistance of  $R_2$  and  $R_3 = \dots\dots\dots\ \Omega$

Step 2: Calculate the total resistance of the three resistors.

total resistance =  $\dots\dots\dots\ \Omega$

[3]

(ii) The reading on the ammeter is 2.7A.

The current in  $R_2$  is 1.8A

Determine the current in  $R_3$ .

Show your working.

current = ..... A [1]

(iii) Explain your answer to (a)(ii).

.....  
..... [1]

(iv) With the switch closed and the current flowing in the circuit, the reading on the voltmeter is 27 V.

The switch is opened, so no current flows in the circuit. The reading on the voltmeter increases to 30 V.

Suggest an explanation for this observation.

.....  
..... [1]

(b) A circuit with a total resistance of  $5.0\ \Omega$  has a current of 9.0A.

Calculate the power consumed in the circuit.

Show your working.

power = ..... W [2]

[Total: 8]

Permission to reproduce items where third-party owned material protected by copyright is included has been sought and cleared where possible. Every reasonable effort has been made by the publisher (UCLES) to trace copyright holders, but if any items requiring clearance have unwittingly been included, the publisher will be pleased to make amends at the earliest possible opportunity.

To avoid the issue of disclosure of answer-related information to candidates, all copyright acknowledgements are reproduced online in the Cambridge Assessment International Education Copyright Acknowledgements Booklet. This is produced for each series of examinations and is freely available to download at [www.cambridgeinternational.org](http://www.cambridgeinternational.org) after the live examination series.

Cambridge Assessment International Education is part of the Cambridge Assessment Group. Cambridge Assessment is the brand name of the University of Cambridge Local Examinations Syndicate (UCLES), which itself is a department of the University of Cambridge.

The Periodic Table of Elements

Group																																																																																	
I	II	III										IV	V	VI	VII	VIII																																																																	
3 <b>Li</b> lithium 7	4 <b>Be</b> beryllium 9	<div style="border: 1px solid black; padding: 5px; width: fit-content; margin: 0 auto;"> <b>Key</b>                      atomic number                      atomic symbol                      name                      relative atomic mass                 </div>																2 <b>He</b> helium 4																																																															
11 <b>Na</b> sodium 23	12 <b>Mg</b> magnesium 24																	5 <b>B</b> boron 11	6 <b>C</b> carbon 12	7 <b>N</b> nitrogen 14	8 <b>O</b> oxygen 16	9 <b>F</b> fluorine 19	10 <b>Ne</b> neon 20	13 <b>Al</b> aluminium 27	14 <b>Si</b> silicon 28	15 <b>P</b> phosphorus 31	16 <b>S</b> sulfur 32	17 <b>Cl</b> chlorine 35.5	18 <b>Ar</b> argon 40	19 <b>K</b> potassium 39	20 <b>Ca</b> calcium 40	21 <b>Sc</b> scandium 45	22 <b>Ti</b> titanium 48	23 <b>V</b> vanadium 51	24 <b>Cr</b> chromium 52	25 <b>Mn</b> manganese 55	26 <b>Fe</b> iron 56	27 <b>Co</b> cobalt 59	28 <b>Ni</b> nickel 59	29 <b>Cu</b> copper 64	30 <b>Zn</b> zinc 65	31 <b>Ga</b> gallium 70	32 <b>Ge</b> germanium 73	33 <b>As</b> arsenic 75	34 <b>Se</b> selenium 79	35 <b>Br</b> bromine 80	36 <b>Kr</b> krypton 84	37 <b>Rb</b> rubidium 85	38 <b>Sr</b> strontium 88	39 <b>Y</b> yttrium 89	40 <b>Zr</b> zirconium 91	41 <b>Nb</b> niobium 93	42 <b>Mo</b> molybdenum 96	43 <b>Tc</b> technetium —	44 <b>Ru</b> ruthenium 101	45 <b>Rh</b> rhodium 103	46 <b>Pd</b> palladium 106	47 <b>Ag</b> silver 108	48 <b>Cd</b> cadmium 112	49 <b>In</b> indium 115	50 <b>Sn</b> tin 119	51 <b>Sb</b> antimony 122	52 <b>Te</b> tellurium 128	53 <b>I</b> iodine 127	54 <b>Xe</b> xenon 131	55 <b>Cs</b> caesium 133	56 <b>Ba</b> barium 137	57–71 lanthanoids	72 <b>Hf</b> hafnium 178	73 <b>Ta</b> tantalum 181	74 <b>W</b> tungsten 184	75 <b>Re</b> rhenium 186	76 <b>Os</b> osmium 190	77 <b>Ir</b> iridium 192	78 <b>Pt</b> platinum 195	79 <b>Au</b> gold 197	80 <b>Hg</b> mercury 201	81 <b>Tl</b> thallium 204	82 <b>Pb</b> lead 207	83 <b>Bi</b> bismuth 209	84 <b>Po</b> polonium —

57 <b>La</b> lanthanum 139	58 <b>Ce</b> cerium 140	59 <b>Pr</b> praseodymium 141	60 <b>Nd</b> neodymium 144	61 <b>Pm</b> promethium —	62 <b>Sm</b> samarium 150	63 <b>Eu</b> europium 152	64 <b>Gd</b> gadolinium 157	65 <b>Tb</b> terbium 159	66 <b>Dy</b> dysprosium 163	67 <b>Ho</b> holmium 165	68 <b>Er</b> erbium 167	69 <b>Tm</b> thulium 169	70 <b>Yb</b> ytterbium 173	71 <b>Lu</b> lutetium 175
89 <b>Ac</b> actinium —	90 <b>Th</b> thorium 232	91 <b>Pa</b> protactinium 231	92 <b>U</b> uranium 238	93 <b>Np</b> neptunium —	94 <b>Pu</b> plutonium —	95 <b>Am</b> americium —	96 <b>Cm</b> curium —	97 <b>Bk</b> berkelium —	98 <b>Cf</b> californium —	99 <b>Es</b> einsteinium —	100 <b>Fm</b> fermium —	101 <b>Md</b> mendelevium —	102 <b>No</b> nobelium —	103 <b>Lr</b> lawrencium —

lanthanoids

actinoids

The volume of one mole of any gas is 24 dm<sup>3</sup> at room temperature and pressure (r.t.p.).