



**Cambridge International Examinations**  
Cambridge International General Certificate of Secondary Education

CANDIDATE  
NAME

CENTRE  
NUMBER

--	--	--	--	--

CANDIDATE  
NUMBER

--	--	--	--



**COMBINED SCIENCE**

**0653/41**

Paper 4 (Extended)

**October/November 2017**

**1 hour 15 minutes**

Candidates answer on the Question Paper.

No Additional Materials are required.

**READ THESE INSTRUCTIONS FIRST**

Write your Centre number, candidate number and name on all the work you hand in.

Write in dark blue or black pen.

You may use an HB pencil for any diagrams or graphs.

Do not use staples, paper clips, glue or correction fluid.

**DO NOT WRITE IN ANY BARCODES.**

Answer **all** questions.

Electronic calculators may be used.

You may lose marks if you do not show your working or if you do not use appropriate units.

A copy of the Periodic Table is printed on page 24.

At the end of the examination, fasten all your work securely together.

The number of marks is given in brackets [ ] at the end of each question or part question.

This document consists of **24** printed pages.

- 1 (a) Use the following words or phrases to complete the flow chart about the transport of oxygen to the tissues of the body.

Each word or phrase may be used once, more than once, or not at all.

aorta      capillaries      muscles      plasma      platelets  
 pulmonary artery      pulmonary vein      red blood cells      white blood cells

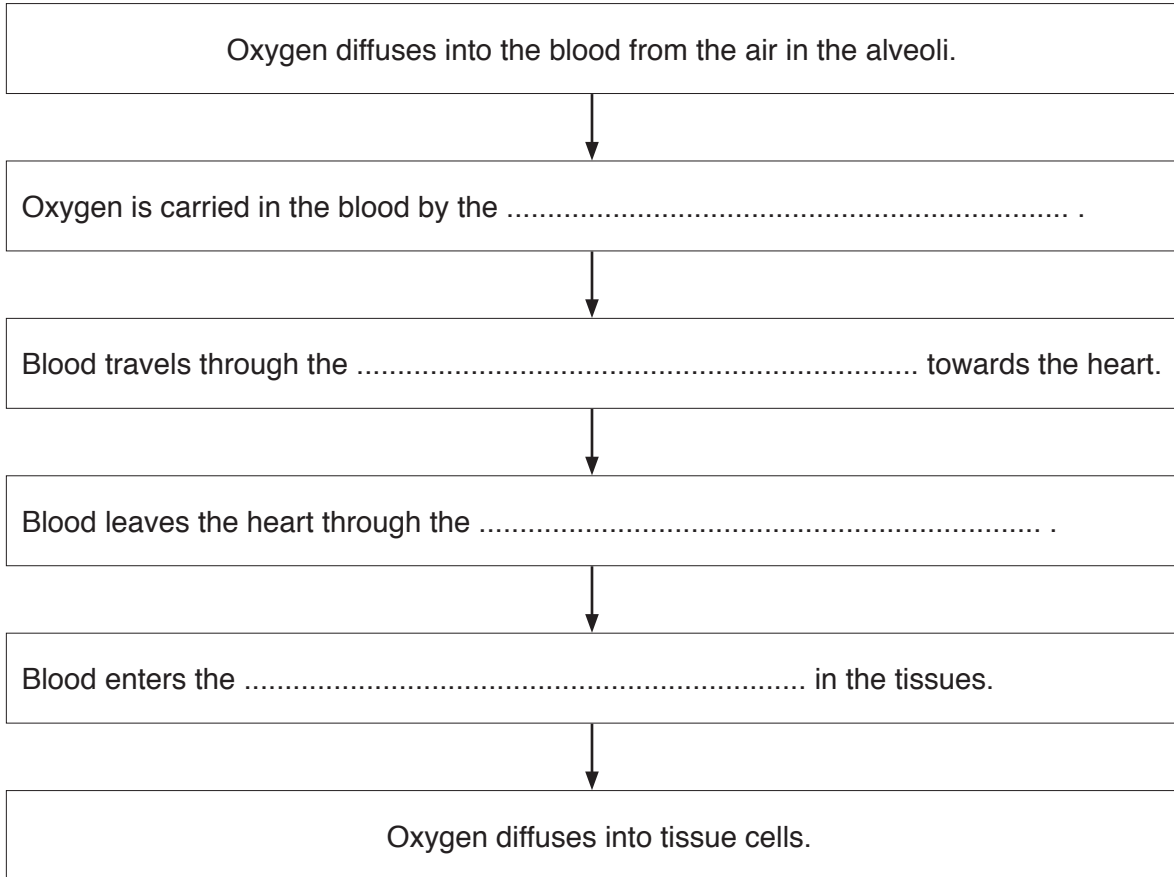

[4]

- (b) Fig. 1.1 shows a cross-sectional diagram of an artery which carries blood away from the heart.

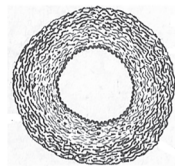

Fig. 1.1

Describe **one** way in which the structure of the wall of the artery helps it to carry out its function.

.....

.....

.....[2]

(c) Fig. 1.2 shows the human gas exchange system.

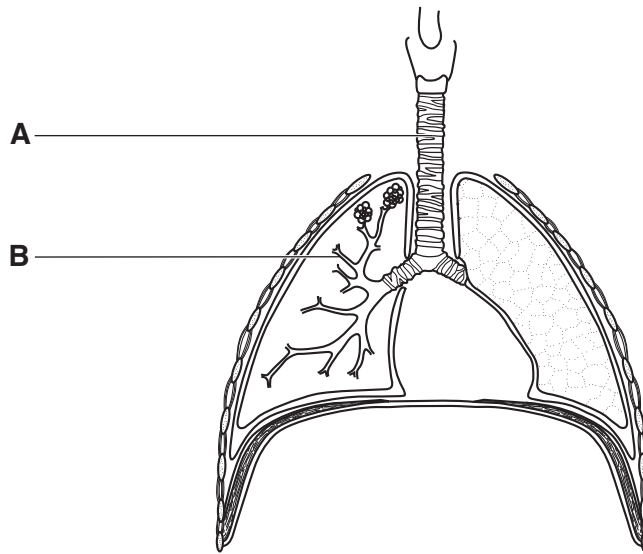

Fig. 1.2

Name the structures **A** and **B** shown in Fig. 1.2.

**A** .....

**B** .....

[2]

(d) Tobacco smoke can have harmful effects on the gas exchange system and the body.

Describe the harmful effects of the following components of tobacco smoke.

nicotine .....

.....

.....

tar .....

.....

.....

[2]

2 (a) Electrolysis is used to break up some compounds into simpler substances.

Fig. 2.1 shows the electrolysis of molten potassium bromide using inert electrodes.

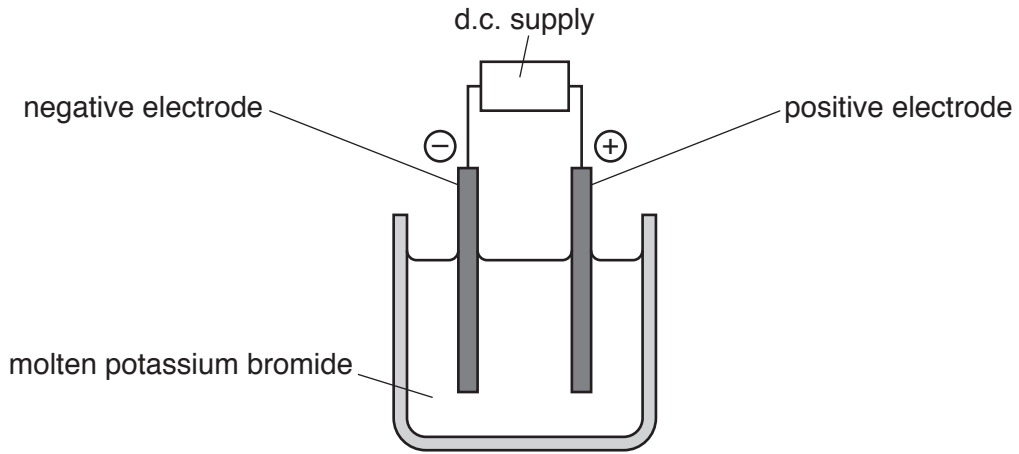

Fig. 2.1

(i) State the names of the negative electrode and of the positive electrode.

negative electrode .....

positive electrode .....

[1]

(ii) Identify the substances formed at the negative electrode and at the positive electrode.

at negative electrode .....

at positive electrode .....

[2]

(iii) Explain, in terms of the ions present, why potassium bromide must be molten during this electrolysis.

.....

.....

.....[1]

- (b) The salt potassium chloride is made when excess solid potassium carbonate reacts with an acid.

A gas is made during this reaction.

- (i) Complete the balanced symbolic equation, with state symbols, for this reaction.



[3]

- (ii) Describe a test to show that a solution contains chloride ions.

test .....

observation .....

[2]

- (iii) A mixture is formed in the reaction between excess solid potassium carbonate and the acid.

Suggest how pure, dry crystals of potassium chloride can be obtained from this mixture.

You may draw a diagram as part of your answer.

.....  
 .....  
 .....[2]

3 Fig. 3.1 shows a guitar.



Fig. 3.1

(a) The guitar produces sounds with frequencies between 80 Hz and 5000 Hz.

(i) State what is meant by a frequency of 80 Hz.

.....[1]

(ii) A guitarist plays a note of frequency 250 Hz twice on his guitar.

The first time he plays the note with a large amplitude.

The second time he plays the note with a small amplitude.

Describe the difference the listener will hear between these two notes.

.....  
.....[1]

(iii) State whether a person with normal hearing can hear all the frequencies produced by this guitar. Give a reason for your answer.

.....  
.....  
.....[1]

(b) At a concert the sound of the guitar is broadcast on a radio programme using radio waves.

A boy in the audience is 100m from the stage. He listens to the guitar on his radio, but he can also hear the sound of the guitar coming directly from the stage.

The boy hears the sound from his radio **before** the same sound comes from the stage.

Explain why the sound coming directly from the stage arrives later than the sound from his radio.

.....

.....

.....[1]

(c) Fig. 3.2 shows a girl using a mirror to see the guitarist over the heads of people.

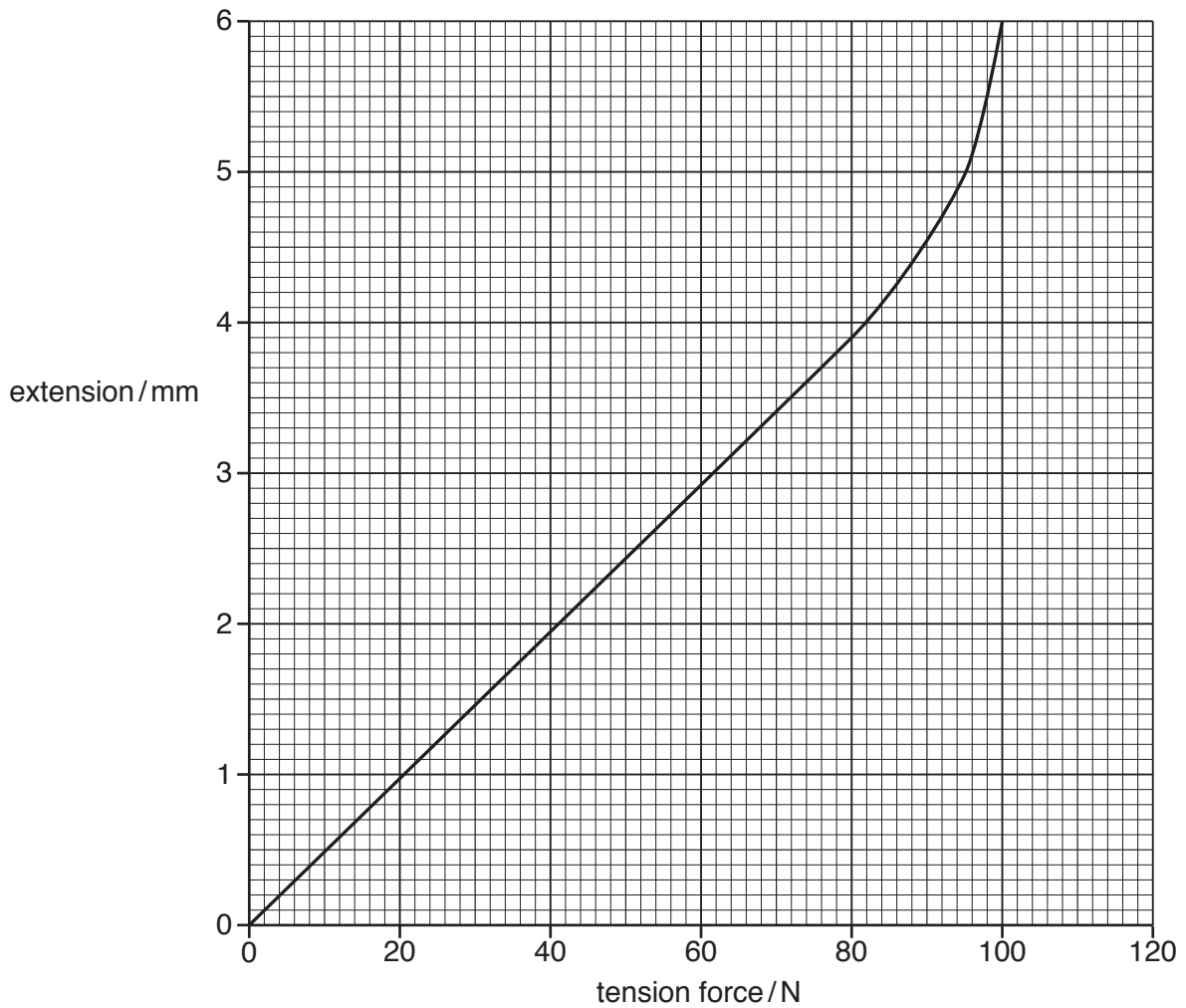

Fig. 3.2

On Fig. 3.2 draw accurately one light ray from the guitarist to show how the girl is able to see the guitarist. [2]

- (d) The guitarist investigates the extension of a guitar string made of steel when different tension forces are used to stretch it.

Fig. 3.3 shows the graph of some results obtained from this experiment.



**Fig. 3.3**

The guitarist adjusts the note played by a guitar string by adjusting the tension force in the string. The more the tension force, the higher the note.

The guitarist must only increase the tension force within the limits where Hooke's Law applies.

- (i) State Hooke's Law.

.....  
 .....[1]

- (ii) Use the graph to identify the limit of proportionality for this guitar string.

.....[1]



- 4 (a) Fig. 4.1 shows some bacterial cells as seen using an electron microscope. They are an example of the microorganisms used in the manufacture of yoghurt.

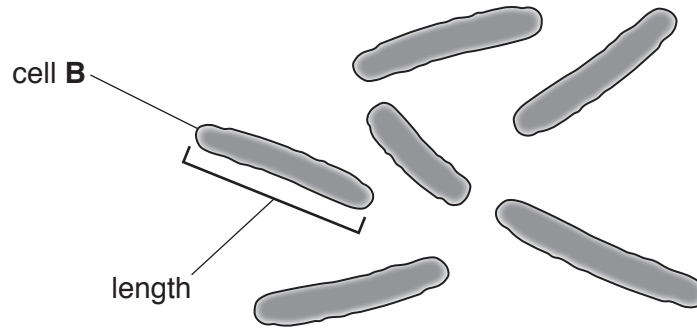

Fig. 4.1

The actual length of cell B is 0.001 mm.

Calculate the magnification of cell B.

magnification = ..... [2]

- (b) The microorganisms break down the sugar in milk. They produce an acid as a waste product. The acid affects the activity of the enzymes in the microorganisms.

(i) Suggest the effect of the acid on the rate of sugar breakdown. Explain your answer.

.....  
.....  
.....[1]

- (ii) Yoghurt can be made at a range of temperatures. However the reaction is usually carried out at 44 °C.

Suggest why the temperature of 44 °C is used, and not a higher temperature.

.....  
.....  
.....[2]

(c) Microorganisms have the role of decomposers in the carbon cycle.

(i) Define the term *decomposer*.

.....  
.....[1]

(ii) Explain **two** reasons why decomposers are essential in the carbon cycle.

1. ....  
.....  
2. ....  
.....  
[2]

5 Petroleum is separated into useful products by process **W** shown in Fig. 5.1.

Process **X** changes some molecules into shorter molecules.

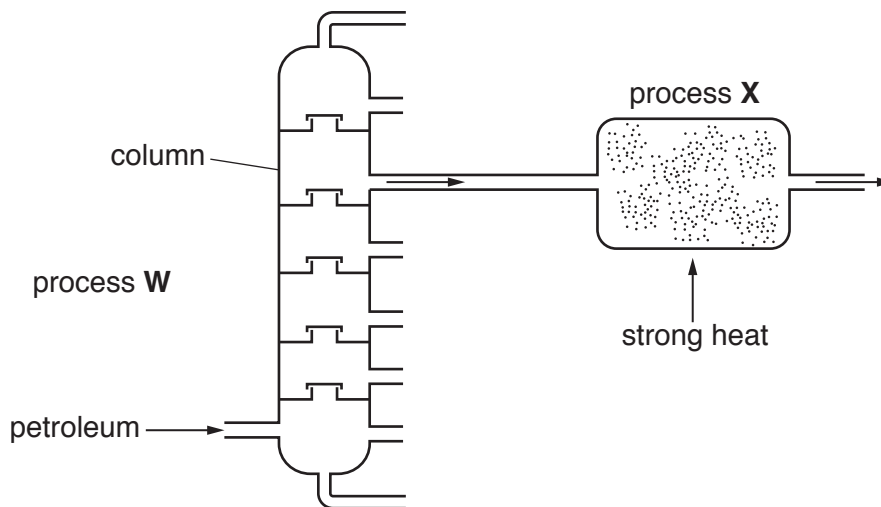

Fig. 5.1

(a) (i) Name process **W** shown in Fig. 5.1.

.....[1]

(ii) Use words from the list to complete the sentences about process **W**.

Each word may be used once, more than once, or not at all.

- |                |                 |               |
|----------------|-----------------|---------------|
| <b>higher</b>  | <b>greater</b>  | <b>lower</b>  |
| <b>smaller</b> | <b>stronger</b> | <b>weaker</b> |

Products with ..... molecular sizes collect at the bottom of the column.

Products with ..... boiling points collect at the top of the column.

Molecules with higher boiling points have ..... intermolecular attractive forces.

[1]

(b) Process **X** produces short hydrocarbon molecules.

Name process **X**.

.....[1]

- (c) Two hydrocarbon molecules, **A** and **B**, are shown in Fig. 5.2.

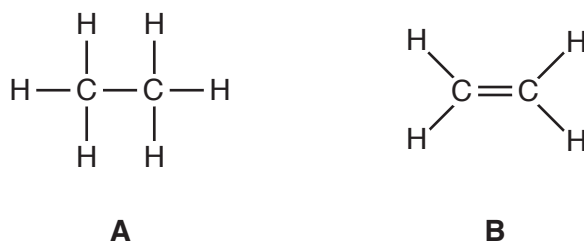

**Fig. 5.2**

- (i) Describe the chemical test that is used to distinguish between these two hydrocarbon molecules.

test .....

observation with **A** .....

observation with **B** .....

[2]

- (ii) Name hydrocarbon **B**.

.....[1]

- (d) Combustion of hydrocarbons produces carbon dioxide.

- (i) Explain why the proportion of carbon dioxide in air is increasing.

.....

.....[1]

- (ii) Explain why people are concerned that the proportion of carbon dioxide in air is increasing.

.....

.....[1]

6 Fig. 6.1 shows a fan heater used to heat a room in cold weather.

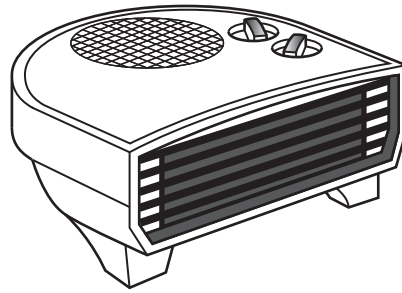
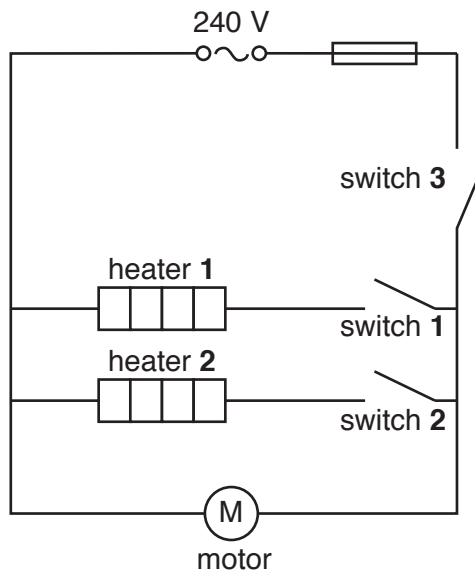

**Fig. 6.1**

The fan heater is connected to the mains electricity supply.

Fig. 6.2 shows the circuit diagram for the fan heater.

The fan heater has two heating elements, heater 1 and heater 2, and a motor to drive the fan, connected to a 240 V mains electricity supply.



**Fig. 6.2**

(a) Deduce which switch or switches must be closed (on) for heater 1 and the motor to work without heater 2.

.....[1]

**(b) (i)** Each heating element has a power consumption of 1100W.

Calculate the current through one heating element when switched on.

State the formula that you use and show your working.

formula

working

current = ..... A [2]

**(ii)** The fan motor is rated at 50 W.

The fuse in the circuit is rated at 10A.

Explain whether this fuse provides good protection if an overload happens.

.....  
.....  
.....[2]

- (c) An electrician wants to measure the current through the fan motor.

Complete the circuit diagram in Fig. 6.3 to show how the electrician should connect a meter to do this.

You should use the correct symbol for the meter to be used, and complete all missing circuit connections.

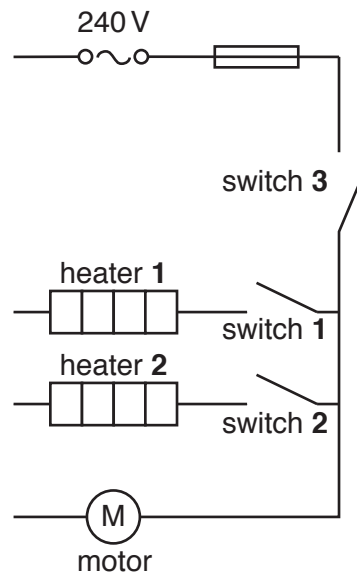

Fig. 6.3

[2]

- 7 Fig. 7.1 shows a sealed glass jar containing soil and plants. An oxygen sensor is used to find out how the concentration of oxygen in the glass jar changes during the day.

The plants can live in the glass jar for several weeks without opening the jar.

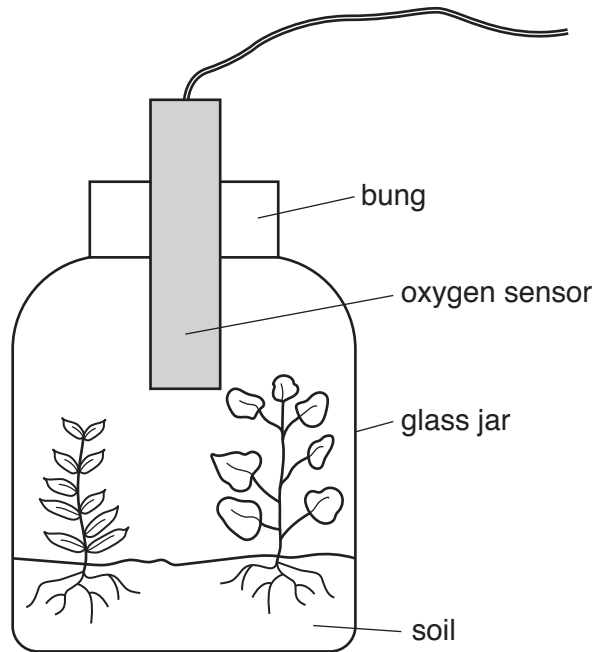

Fig. 7.1

- (a) The plants in Fig. 7.1 use carbon dioxide for photosynthesis.

Explain why they do not run out of carbon dioxide in the sealed jar.

.....  
.....  
.....[2]

- (b) The water needed for photosynthesis enters the root hair cells of the plants.

Describe how the structure of a root hair cell adapts it for water uptake.

.....  
.....  
.....  
.....[2]



- (c) Fig. 7.2 shows a graph of the oxygen concentration in the glass jar shown in Fig. 7.1 over a 12-hour period on a sunny day.

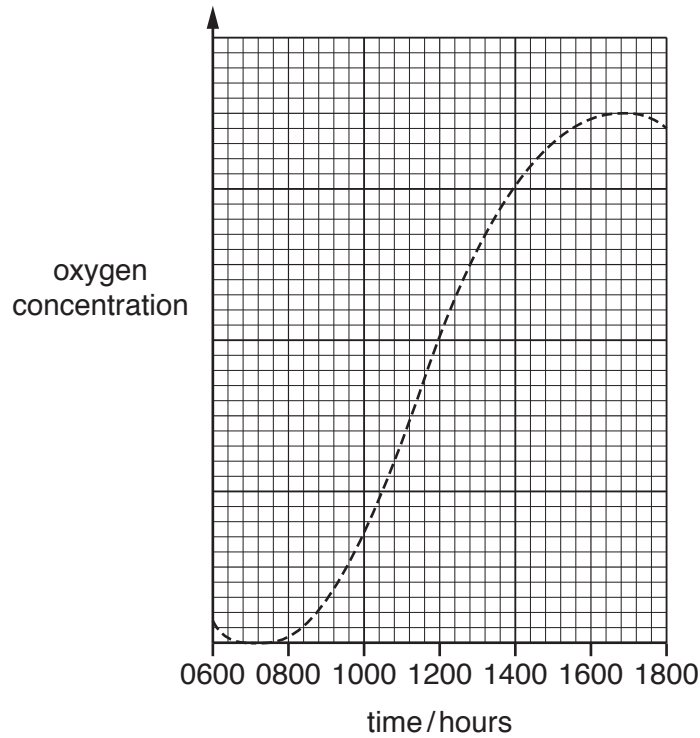

**Fig. 7.2**

Oxygen is produced by photosynthesis taking place in the plant.

- (i) State a time at which the rate of photosynthesis is highest.

Explain your answer.

time .....

explanation .....

.....

.....

[2]

- (ii) On a different day the graph follows a similar pattern as Fig. 7.2 until 10.00 hours.

After 10.00 hours the weather changes and it becomes darker.

On Fig. 7.2 draw a line to show how the oxygen production changes after this time.

Explain your answer.

.....

.....

.....[2]

- 8 (a) An atom of phosphorus is represented as shown.



- (i) State the number of protons and neutrons in this atom of phosphorus.

number of protons .....

number of neutrons .....

[2]

- (ii) Deduce the electronic structure of an atom of phosphorus.

.....

[1]

- (b) Nitrogen, N, is in the same group of the Periodic Table as phosphorus.

Nitrogen forms molecules, N<sub>2</sub>.

- (i) State the type of chemical bonding in a molecule of nitrogen.

.....[1]

- (ii) Complete the dot-and-cross diagram to show the multiple bonds in a molecule of nitrogen.

N                  N

[1]

- (c) The noble gases, in Group VIII of the Periodic Table, are unreactive and do not bond with other elements.

State **one** use for helium.

.....[1]

- (d) Lithium, sodium and potassium are Group I metals.

Explain why these metals **cannot** be extracted from their ores by heating the ores with carbon.

.....

.....[1]

- (e) The melting points and physical states at room temperature of the first four elements in Group VII are shown in Table 8.1.

**Table 8.1**

element	physical state	melting point/°C
fluorine	gas	-220
chlorine	gas	-101
bromine	liquid	-7
iodine	solid	114
astatine		

Complete Table 8.1 by predicting the physical state and melting point of astatine, the fifth element in Group VII. [1]

9 Fig. 9.1 shows the horizontal and vertical forces which act on a car on a level road.

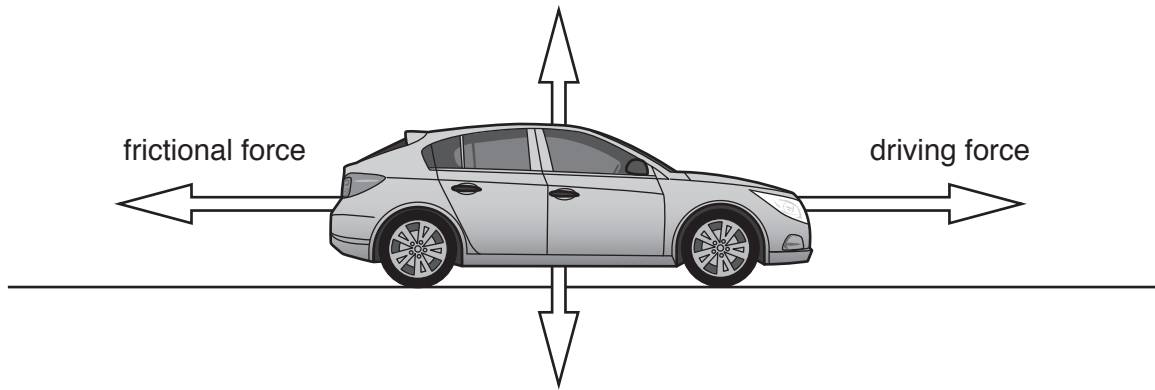
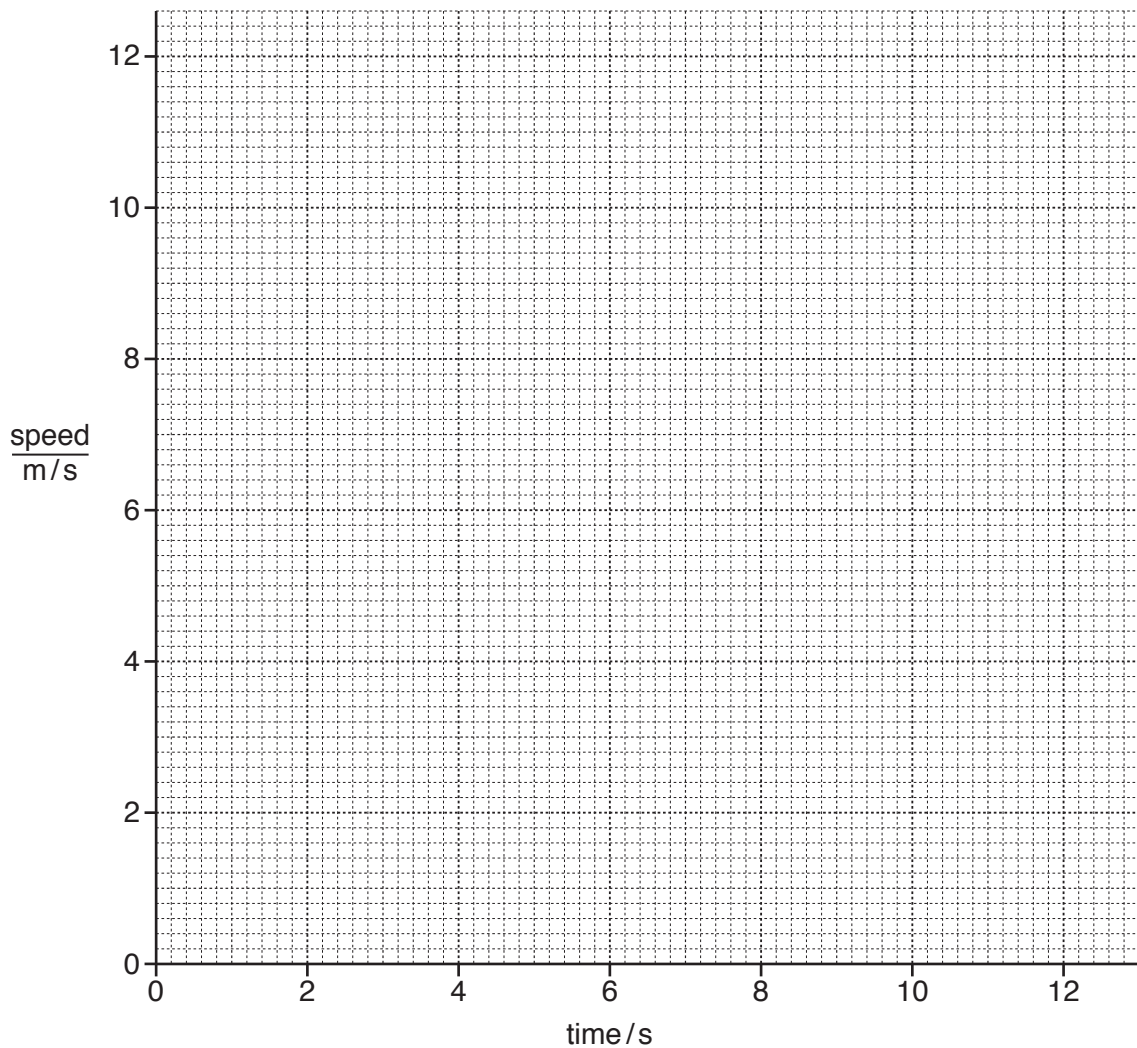

Fig. 9.1

- (a) (i) Name the force represented by the arrow pointing downwards.  
 .....[1]
- (ii) After the car starts to move, the driving force is constant, but the frictional force increases. The car reaches a speed of 10 m/s after 12 seconds.

On the grid below sketch a speed-time graph for this part of the journey.



[2]

(b) The car is powered by batteries that can be recharged from solar cells when the batteries run down.

(i) 40 000 000 J of electrical energy are needed to charge the batteries from the solar cells.

The solar cells have an efficiency of 20%.

Calculate the energy input from the Sun to the solar cells required to charge the batteries.

State the formula that you use and show your working.

formula

working

energy input = ..... J [2]

(ii) Electric cars are intended to replace cars that use fossil fuels. The electricity is usually generated by power stations, many of which use non-renewable resources such as fossil fuels.

Solar panels are a renewable energy resource.

State two other renewable energy resources that can be used to generate electricity.

..... and ..... [2]

(c) Fig. 9.2 shows the car crossing a bridge.

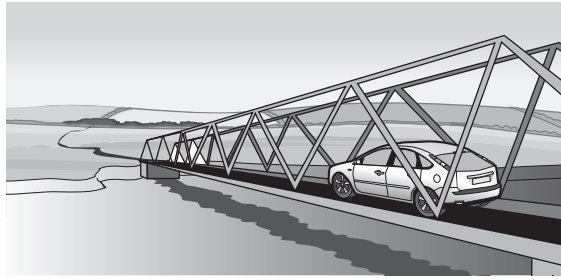

Fig. 9.2

Fig. 9.3 shows a gap in the road surface on the bridge.

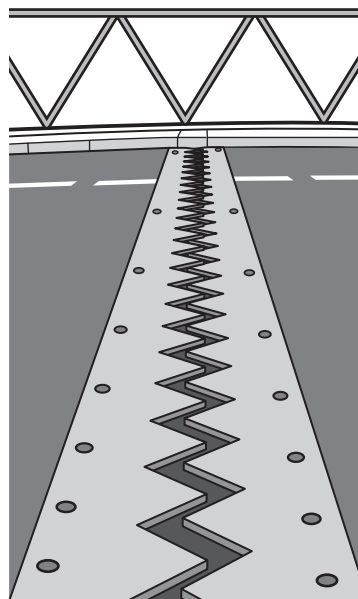

Fig. 9.3

(i) On a hot sunny day the temperature of the bridge rises and the gap shown closes.

Explain why this happens.

.....  
.....[1]

(ii) Suggest what might happen to the bridge on a hot sunny day if this gap was not provided.

.....  
.....[1]

(iii) Use words from the list below to complete the blanks in the sentence that follows.

Each word may be used once, more than once, or not at all.

**boils      evaporates      faster      larger      melts      slower      smaller**

After rain, the road surface is wet with water which slowly .....  
as the ..... molecules escape from the water surface. [2]

(iv) On a cold winter's day, the temperature is  $-5^{\circ}\text{C}$ .

Water vapour in the air freezes onto the road surface as ice.

On Fig. 9.4 draw a line to link the correct arrangement of molecules in water vapour to the correct arrangement of molecules in ice.

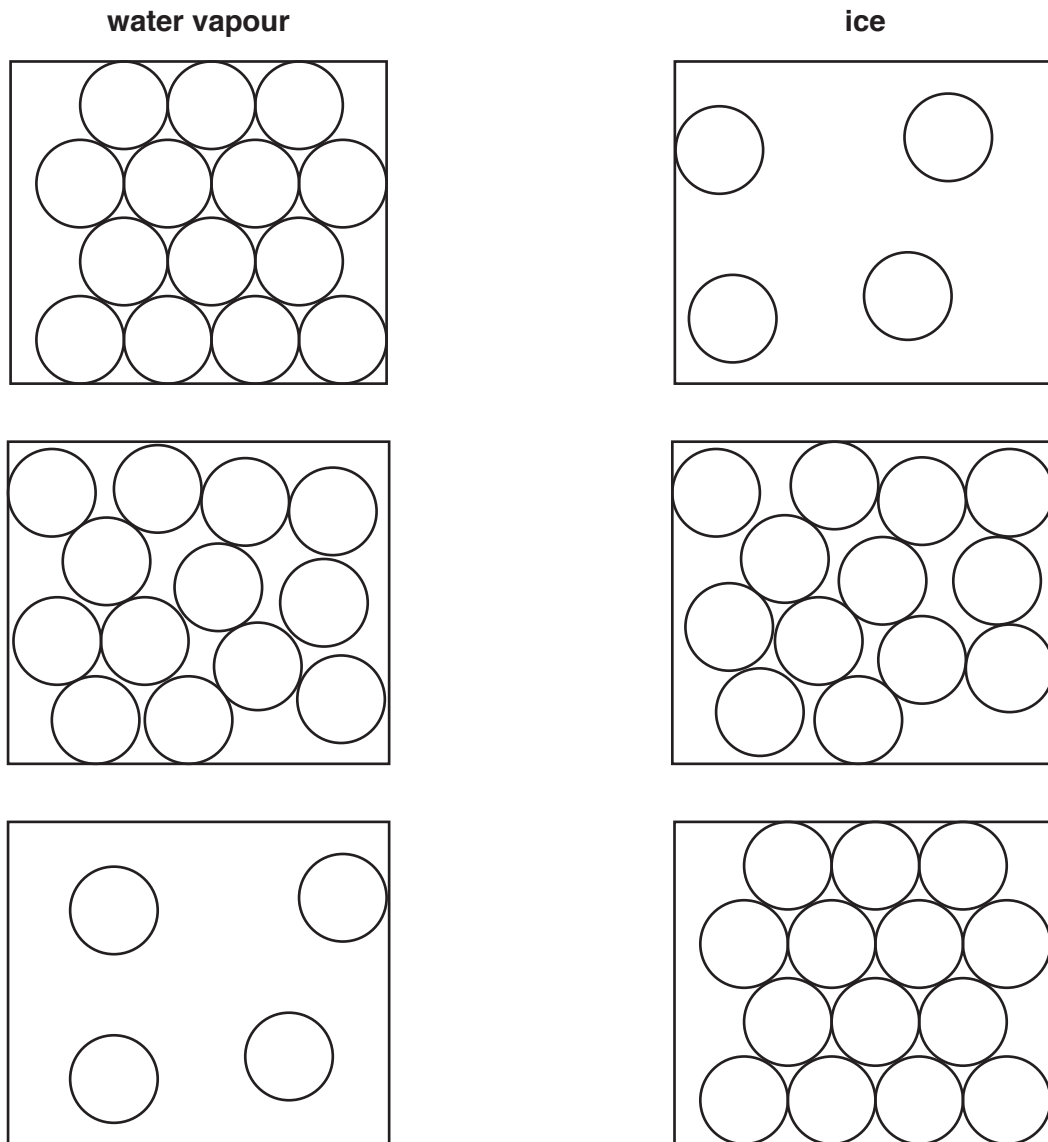

Fig. 9.4

[1]

The Periodic Table of Elements

		Group															
I	II	III	IV	V	VI	VII	VIII										
3 <b>Li</b> lithium 7	4 <b>Be</b> beryllium 9	5 <b>B</b> boron 11	6 <b>C</b> carbon 12	7 <b>N</b> nitrogen 14	8 <b>O</b> oxygen 16	9 <b>F</b> fluorine 19	10 <b>Ne</b> neon 20										
11 <b>Na</b> sodium 23	12 <b>Mg</b> magnesium 24	13 <b>Al</b> aluminium 27	14 <b>Si</b> silicon 28	15 <b>P</b> phosphorus 31	16 <b>S</b> sulfur 32	17 <b>Cl</b> chlorine 35.5	18 <b>Ar</b> argon 40										
19 <b>K</b> potassium 39	20 <b>Ca</b> calcium 40	21 <b>Sc</b> scandium 45	22 <b>Ti</b> titanium 48	23 <b>V</b> vanadium 51	24 <b>Cr</b> chromium 52	25 <b>Mn</b> manganese 55	26 <b>Fe</b> iron 56	27 <b>Co</b> cobalt 59	28 <b>Ni</b> nickel 59	29 <b>Cu</b> copper 64	30 <b>Zn</b> zinc 65	31 <b>Ga</b> gallium 70	32 <b>Ge</b> germanium 73	33 <b>As</b> arsenic 75	34 <b>Se</b> selenium 79	35 <b>Br</b> bromine 80	36 <b>Kr</b> krypton 84
37 <b>Rb</b> rubidium 85	38 <b>Sr</b> strontium 88	39 <b>Y</b> yttrium 89	40 <b>Zr</b> zirconium 91	41 <b>Nb</b> niobium 93	42 <b>Mo</b> molybdenum 96	43 <b>Tc</b> technetium —	44 <b>Ru</b> ruthenium 101	45 <b>Rh</b> rhodium 103	46 <b>Pd</b> palladium 106	47 <b>Ag</b> silver 108	48 <b>Cd</b> cadmium 112	49 <b>In</b> indium 115	50 <b>Sn</b> tin 119	51 <b>Sb</b> antimony 122	52 <b>Te</b> tellurium 128	53 <b>I</b> iodine 127	54 <b>Xe</b> xenon 131
55 <b>Cs</b> caesium 133	56 <b>Ba</b> barium 137	57–71 lanthanoids	72 <b>Hf</b> hafnium 178	73 <b>Ta</b> tantalum 181	74 <b>W</b> tungsten 184	75 <b>Re</b> rhenium 186	76 <b>Os</b> osmium 190	77 <b>Ir</b> iridium 192	78 <b>Pt</b> platinum 195	79 <b>Au</b> gold 197	80 <b>Hg</b> mercury 201	81 <b>Tl</b> thallium 204	82 <b>Pb</b> lead 207	83 <b>Bi</b> bismuth 209	84 <b>Po</b> polonium —	85 <b>At</b> astatine —	86 <b>Rn</b> radon —
87 <b>Fr</b> francium —	88 <b>Ra</b> radium —	89–103 actinoids	104 <b>Rf</b> rutherfordium —	105 <b>Db</b> dubnium —	106 <b>Sg</b> seaborgium —	107 <b>Bh</b> bohrium —	108 <b>Hs</b> hassium —	109 <b>Mt</b> meitnerium —	110 <b>Ds</b> darmstadtium —	111 <b>Rg</b> roentgenium —	112 <b>Cn</b> copernicium —	114 <b>Fl</b> flerovium —	116 <b>Lv</b> livermorium —				

1  
**H**  
hydrogen  
1

**Key**  
atomic number  
atomic symbol  
name  
relative atomic mass

57 <b>La</b> lanthanum 139	58 <b>Ce</b> cerium 140	59 <b>Pr</b> praseodymium 141	60 <b>Nd</b> neodymium 144	61 <b>Pm</b> promethium —	62 <b>Sm</b> samarium 150	63 <b>Eu</b> europium 152	64 <b>Gd</b> gadolinium 157	65 <b>Tb</b> terbium 159	66 <b>Dy</b> dysprosium 163	67 <b>Ho</b> holmium 165	68 <b>Er</b> erbium 167	69 <b>Tm</b> thulium 169	70 <b>Yb</b> ytterbium 173	71 <b>Lu</b> lutetium 175
89 <b>Ac</b> actinium —	90 <b>Th</b> thorium 232	91 <b>Pa</b> protactinium 231	92 <b>U</b> uranium 238	93 <b>Np</b> neptunium —	94 <b>Pu</b> plutonium —	95 <b>Am</b> americium —	96 <b>Cm</b> curium —	97 <b>Bk</b> berkelium —	98 <b>Cf</b> californium —	99 <b>Es</b> einsteinium —	100 <b>Fm</b> fermium —	101 <b>Md</b> mendelevium —	102 <b>No</b> nobelium —	103 <b>Lr</b> lawrencium —

lanthanoids

actinoids

The volume of one mole of any gas is 24 dm<sup>3</sup> at room temperature and pressure (r.t.p.).