



Cambridge International Examinations
Cambridge International General Certificate of Secondary Education

COMBINED SCIENCE

0653/23

Paper 2 Multiple Choice (Extended)

October/November 2017

45 minutes

Additional Materials: Multiple Choice Answer Sheet
 Soft clean eraser
 Soft pencil (type B or HB is recommended)

* 4 0 5 8 2 8 8 9 3 5 4 *

READ THESE INSTRUCTIONS FIRST

Write in soft pencil.
Do not use staples, paper clips, glue or correction fluid.
Write your name, Centre number and candidate number on the Answer Sheet in the spaces provided unless this has been done for you.
DO NOT WRITE IN ANY BARCODES.

There are **forty** questions on this paper. Answer **all** questions. For each question there are four possible answers **A, B, C** and **D**.
Choose the **one** you consider correct and record your choice in **soft pencil** on the separate Answer Sheet.

Read the instructions on the Answer Sheet very carefully.

Each correct answer will score one mark. A mark will not be deducted for a wrong answer.
Any rough working should be done in this booklet.
A copy of the Periodic Table is printed on page 20.
Electronic calculators may be used.

This document consists of **17** printed pages and **3** blank pages.

1 Which characteristics help to define a living organism?

- A diffusion, movement, respiration
- B excretion, nutrition, sensitivity
- C excretion, reproduction, transpiration
- D growth, inspiration, nutrition

2 The diagram shows a palisade cell.

Which structure converts energy from light into chemical energy?

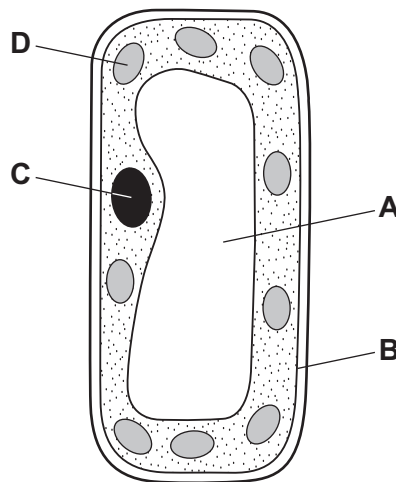

3 Which substance is produced by respiration in microorganisms during yoghurt making?

- A amino acids
- B fatty acids
- C hydrochloric acid
- D lactic acid

4 The list shows chemicals that are important to a plant.

- 1 carbon dioxide
- 2 nitrates
- 3 oxygen
- 4 water

Which chemicals does a plant use in photosynthesis?

- A 1, 2 and 4
- B 1 and 2 only
- C 1 and 4 only
- D 3 and 4 only

5 In which order does food pass through parts of the alimentary canal?

- A oesophagus → colon → small intestine
- B small intestine → oesophagus → rectum
- C small intestine → rectum → anus
- D stomach → colon → small intestine

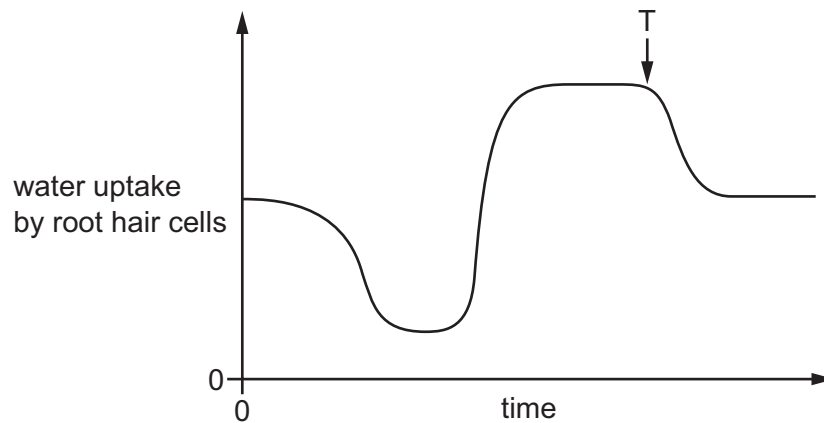

6 The graph shows the uptake of water by root hair cells over many hours during a day.



What could have caused the change in the rate of uptake at T?

- A decrease in temperature
- B decrease in humidity
- C increase in light intensity
- D increase in temperature

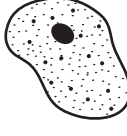
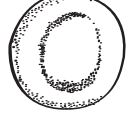
7 Which row correctly matches the cell to its function?

	cell	function
A		blood clotting
B		blood clotting
C		oxygen transport
D		oxygen transport

8 Dust particles and pathogens may be inhaled from the air. These can cause damage to the airways if they are not removed.

Which features work together to remove them from the airways?

- A** cilia and enzymes
 - B** mucus and cilia
 - C** mucus and saliva
 - D** saliva and enzymes
- 9 How does auxin cause a plant shoot to bend to the right?
- A** Cells elongate more on the left side of the shoot than on the right side.
 - B** Cells elongate more on the right side of the shoot than on the left side.
 - C** Cells shrink on the left side of the shoot.
 - D** Cells shrink on the right side of the shoot.

10 The table shows features of four flowers.

Which row shows features of a typical wind-pollinated flower?

	petals	pollen grains	shape of stigma
A	large white petals and sweet scent	large and hooked	branched and feathery
B	large white petals and sweet scent	small and light	straight and enclosed within the flower
C	small green petals and no scent	large and hooked	straight and enclosed within the flower
D	small green petals and no scent	small and light	branched and feathery

11 During pregnancy, the fetus is contained within the amniotic sac. The amniotic sac contains amniotic fluid.

What is the function of the amniotic fluid?

- A** It protects the fetus against knocks and bumps.
- B** It provides the fetus with oxygen and nutrients.
- C** It removes the fetal waste products.
- D** It supplies the fetus with blood.

12 The diagram shows the trophic levels of a food chain.

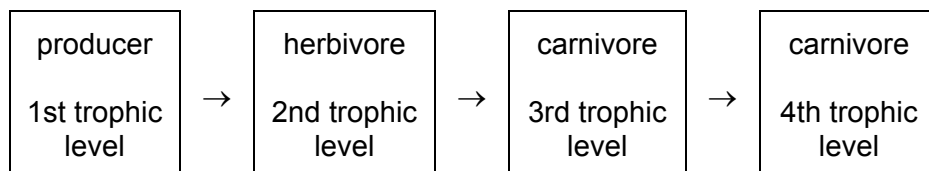

Why do most food chains **not** have more than four trophic levels?

- A** There are too many carnivores in the 3rd trophic level.
- B** There are too many herbivores in the 2nd trophic level.
- C** There is no energy transferred from the 2nd trophic level to the 3rd trophic level.
- D** There is not enough energy available to be transferred to a 5th trophic level.

13 The graph shows changes in the number of different species in the water flowing along a river.

At which point is untreated sewage released into the river?

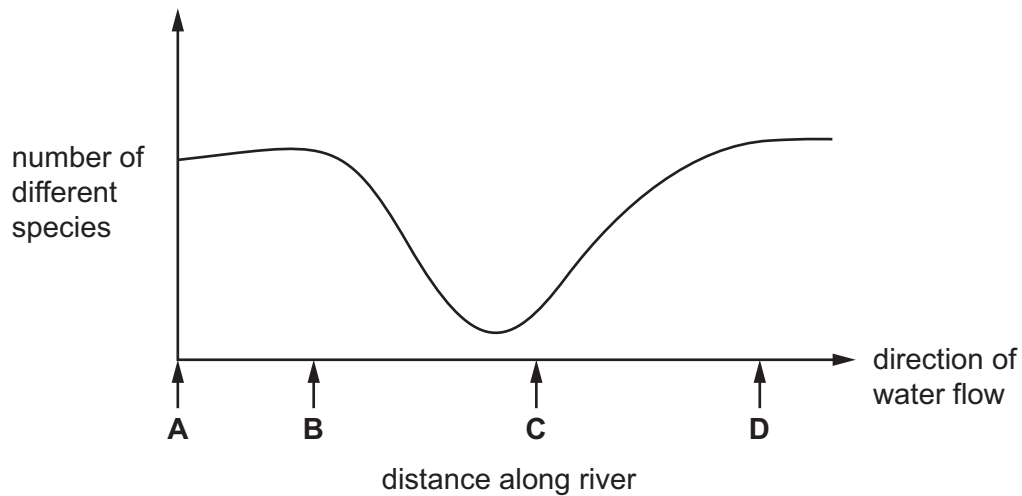

14 The formulae of three substances are shown.

substance	formula
methane	CH ₄
water	H ₂ O
oxygen	O ₂

Which statement is correct?

- A Methane is made from five different types of atom.
- B Methane, water and oxygen are molecules.
- C Only methane and water are molecules.
- D Oxygen is made from two different types of atom.

15 Chromatography separates ink into different colours.

Which diagram shows how the apparatus is set up?

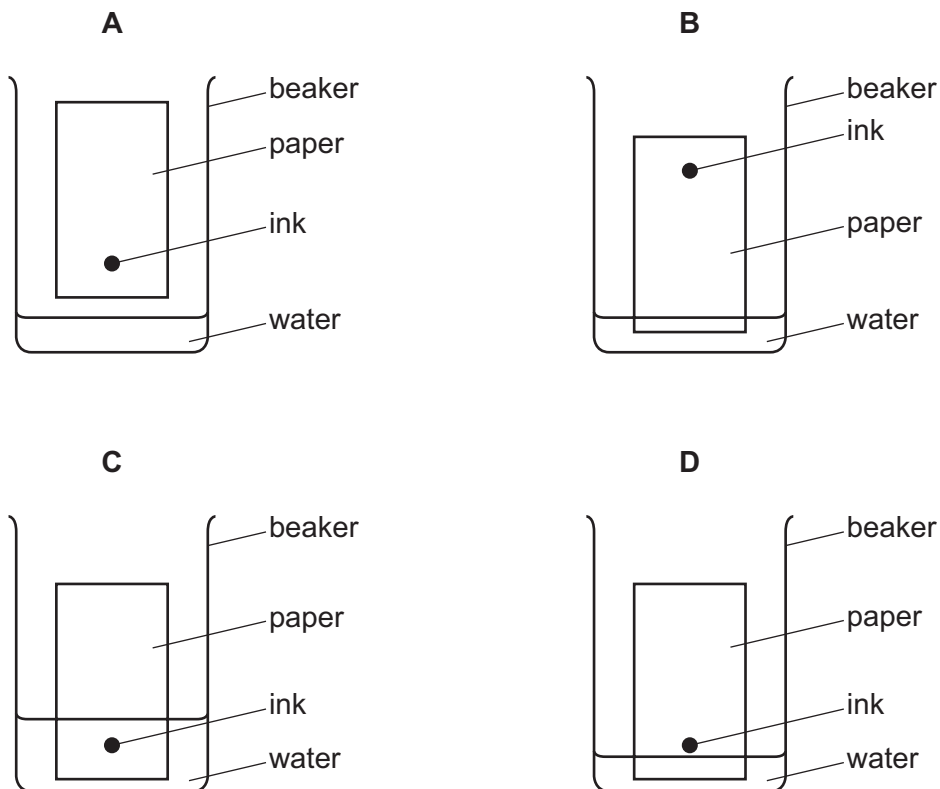

16 Which statement describes how sodium atoms and oxygen atoms combine to form sodium oxide, Na_2O ?

- A One sodium atom gains two electrons and two oxygen atoms lose one electron each.
- B One sodium atom loses two electrons and two oxygen atoms gain one electron each.
- C Two sodium atoms gain one electron each and one oxygen atom loses two electrons.
- D Two sodium atoms lose one electron each and one oxygen atom gains two electrons.

17 Which dot-and-cross diagrams show the outer-shell electrons in molecules of water and of carbon dioxide?

	water	carbon dioxide
A	$\text{H} \times \text{O} \times \text{H}$	$\begin{array}{c} \times \times \times \times \\ \times \text{O} \times \text{C} \times \text{O} \times \\ \times \times \times \times \end{array}$
B	$\text{H} \times \text{O} \times \text{H}$	$\begin{array}{c} \times \times \times \times \\ \times \text{O} \times \text{C} \times \text{O} \times \\ \times \times \times \times \end{array}$
C	$\begin{array}{c} \times \times \\ \text{H} \times \text{O} \times \text{H} \\ \times \times \end{array}$	$\begin{array}{c} \times \times \times \times \\ \times \text{O} \times \text{C} \times \text{O} \times \\ \times \times \times \times \end{array}$
D	$\begin{array}{c} \times \times \\ \text{H} \times \text{O} \times \text{H} \\ \times \times \end{array}$	$\begin{array}{c} \times \times \times \times \\ \times \text{O} \times \text{C} \times \text{O} \times \\ \times \times \times \times \end{array}$

18 The formulae of some ions are shown.

- ammonium, NH_4^+
- calcium, Ca^{2+}
- nitrate, NO_3^-
- phosphate, PO_4^{3-}

What is the formula of calcium nitrate and of ammonium phosphate?

	calcium nitrate	ammonium phosphate
A	$\text{Ca}(\text{NO}_3)_2$	$\text{NH}_4(\text{PO}_4)_3$
B	$\text{Ca}(\text{NO}_3)_2$	$(\text{NH}_4)_3\text{PO}_4$
C	Ca_2NO_3	$\text{NH}_4(\text{PO}_4)_3$
D	Ca_2NO_3	$(\text{NH}_4)_3\text{PO}_4$

19 Which row describes an ionic compound?

	melting point	can be electrolysed
A	high	no
B	high	yes
C	low	no
D	low	yes

20 The diagram shows gas X burning and heating a liquid.

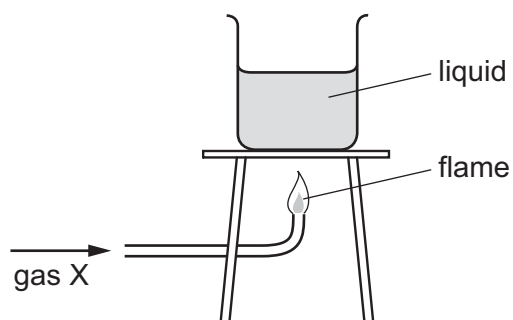

Which row is correct?

	gas X	the burning of gas X is exothermic
A	hydrogen	✓
B	hydrogen	x
C	oxygen	✓
D	oxygen	x

21 Dilute hydrochloric acid reacts with marble pieces to produce carbon dioxide.

The results of some experiments to investigate the rate of reaction are shown.

relative concentration of hydrochloric acid	size of marble pieces	time taken to make 50 cm ³ of carbon dioxide / s
1	large	100
2	large	50
1	small	80
2	small	40

Which conclusion can be made from these results?

- A When bigger marble pieces are used, the rate of reaction is greater.
- B When smaller marble pieces are used, the rate of reaction is doubled.
- C When the concentration is doubled, the rate of reaction is doubled.
- D When the concentration is doubled, the rate of reaction is halved.

22 Copper is produced by heating copper oxide with carbon.

The word equation for this reaction is shown.

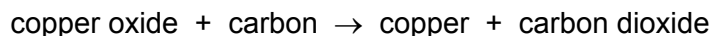

Which statement explains why this is a redox reaction?

- A Carbon dioxide contains oxygen.
- B Carbon is a solid and carbon dioxide is a gas.
- C Copper oxide is oxidised.
- D Copper oxide loses oxygen and carbon gains oxygen.

23 Excess aqueous barium nitrate is added to dilute sulfuric acid to produce barium sulfate.

How is barium sulfate obtained from the reaction mixture?

- A electrolysis
- B evaporation
- C filtration
- D fractional distillation

24 What is a use for argon?

- A as a fuel
- B filling balloons
- C providing an inert atmosphere
- D the extraction of copper

25 Which diagram shows the arrangements of atoms in an alloy?

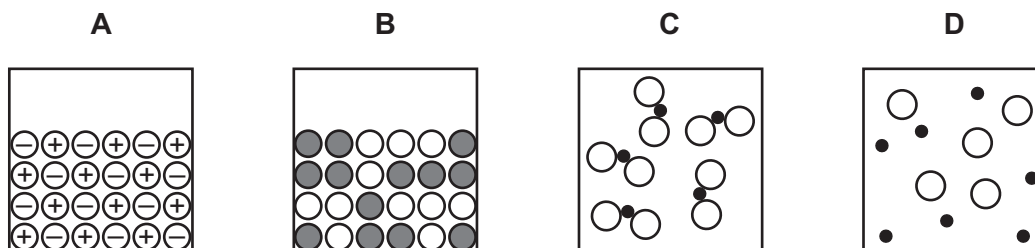

26 P, Q, R and S are four gases found in clean air.

P is very unreactive.

Q makes up 21% of the air.

R makes up 78% of the air.

S is formed when fossil fuels are burned.

Which row is correct?

	P	Q	R	S
A	argon	nitrogen	oxygen	carbon dioxide
B	argon	oxygen	nitrogen	carbon dioxide
C	carbon dioxide	oxygen	nitrogen	argon
D	carbon dioxide	nitrogen	oxygen	argon

27 Which statement about the fractional distillation of petroleum is **not** correct?

- A Fractions obtained from higher up the fractional distillation column have higher boiling point ranges.
- B Fractions obtained from lower down the fractional distillation column contain larger molecules.
- C Refinery gas is used for heating and cooking.
- D Smaller molecules have weaker intermolecular attractive forces.

28 The diagram shows the speed-time graph for a car.

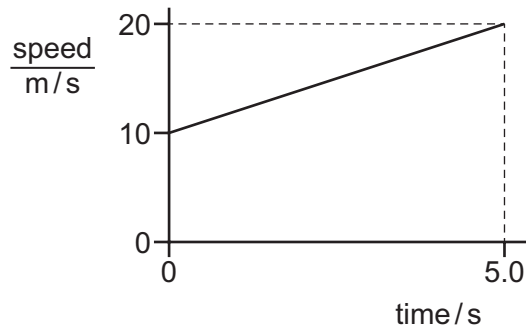

What is the acceleration of the car?

- A** 2.0 m/s^2 **B** 4.0 m/s^2 **C** 50 m/s^2 **D** 75 m/s^2

29 Which conditions are necessary for an object to have weight?

	must have mass	must be in a gravitational field	must be in an electric field
A	no	yes	no
B	no	yes	yes
C	yes	no	yes
D	yes	yes	no

30 A student stretches a steel spring by hanging a load on it. The measurements for the extension of the spring are shown in the table.

load / N	1.0	2.0	3.0	4.0	5.0	6.0
extension / cm	0.5	1.0	1.5	2.0	2.5	3.0

What is the value for the spring constant k of the spring?

- A** 0.50 N/cm **B** 1.0 N/cm **C** 2.0 N/cm **D** 18 N/cm

31 A motor is used to lift a load of 3000 N through a vertical height of 40 m in 2.0 minutes.

How much useful power does the motor produce?

- A** 1000 W **B** 9000 W **C** 60 000 W **D** 240 000 W

- 32** The molecules of a substance are far apart and moving at high speeds in straight lines. The forces between them are negligible.

Two changes are now made to the substance.

change 1 The average speed of the molecules is reduced but they remain far apart.

change 2 The molecules move much closer together. There are much stronger forces between them, but they can change places with each other.

What is the effect of each change?

	change 1	change 2
A	temperature decreases	gas to liquid
B	temperature decreases	liquid to solid
C	temperature increases	gas to liquid
D	temperature increases	liquid to solid

- 33** The diagram shows an air-conditioning unit on the wall of a room. The unit draws in warm air from the room and releases cold air into the room.

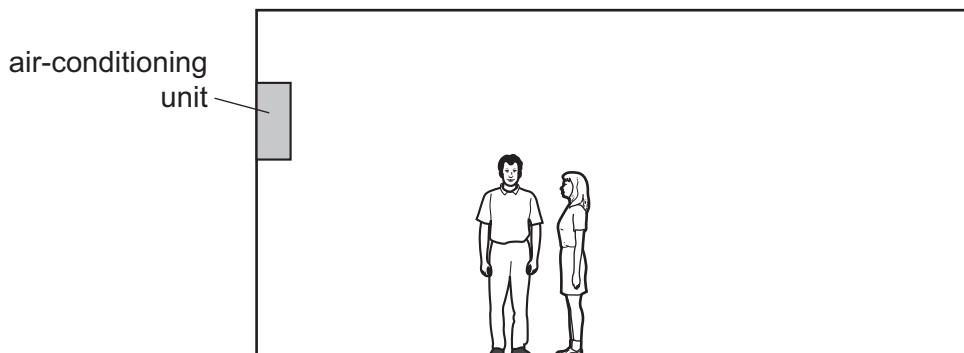

What happens to the cold air and what is the reason?

	cold air	reason
A	falls	it is less dense than warm air
B	falls	it is more dense than warm air
C	rises	it is less dense than warm air
D	rises	it is more dense than warm air

34 The diagram shows a section of a rope.

Four wave crests pass a point on the rope every second.

Each wave crest travels 80 cm in one second.

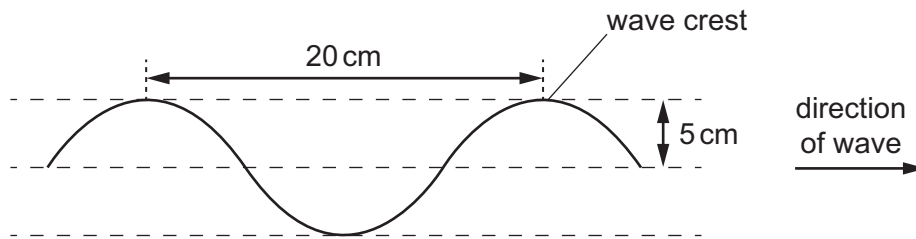

What is the speed of the wave?

- A** 4.0 cm/s **B** 5.0 cm/s **C** 20 cm/s **D** 80 cm/s

35 A man stands a distance d in front of a plane mirror and views his own image in the mirror.

Is the image real or virtual, and what is the distance between the man and his image?

	image	distance between man and image
A	real	d
B	real	$2d$
C	virtual	d
D	virtual	$2d$

36 Electromagnetic waves are used to scan passengers' luggage before they board an aeroplane.

Electromagnetic waves are also used in a television remote controller.

Which type of electromagnetic wave is used for each of these purposes?

	scanning luggage	television remote controller
A	radio waves	infra-red waves
B	radio waves	ultraviolet waves
C	X-rays	infra-red waves
D	X-rays	ultraviolet waves

- 37 The diagram represents a wave in air. Molecules are closer together in region P than they are in region Q.

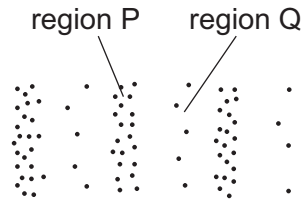

What are the names of regions P and Q, and which type of wave is represented?

	region P	region Q	type of wave
A	compression	rarefaction	longitudinal
B	compression	rarefaction	transverse
C	rarefaction	compression	longitudinal
D	rarefaction	compression	transverse

- 38 Which circuit is used to determine the resistance of the resistor R?

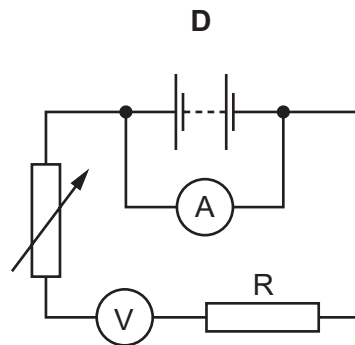
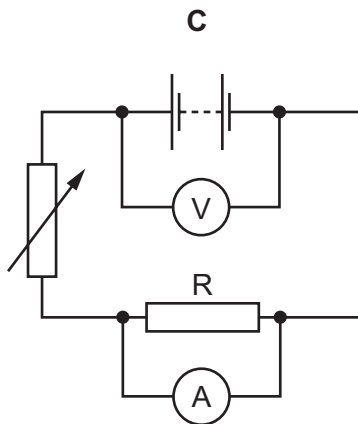
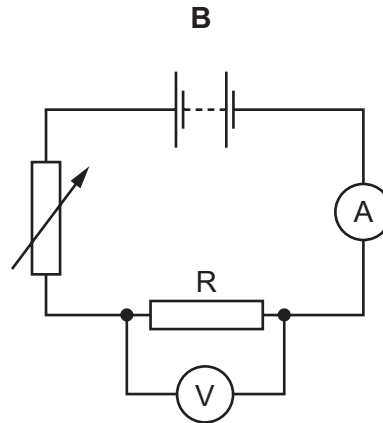
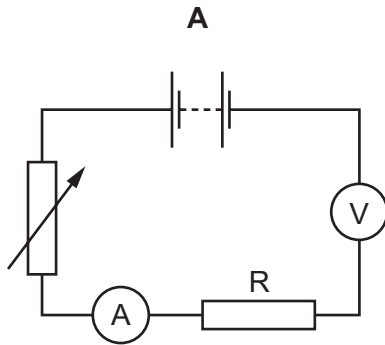

- 39 The device Z in this circuit is designed to cut off the electricity supply **automatically** if too much current flows.

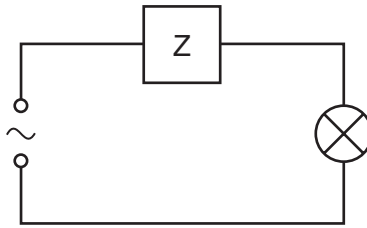

What is device Z?

- A** a fuse
B a resistor
C a switch
D an ammeter
- 40 The diagram shows a 12V battery connected to a 2.0Ω resistor, a 4.0Ω resistor and resistor R.
 The current at two points in the circuit and the p.d. across the 2.0Ω resistor are shown.

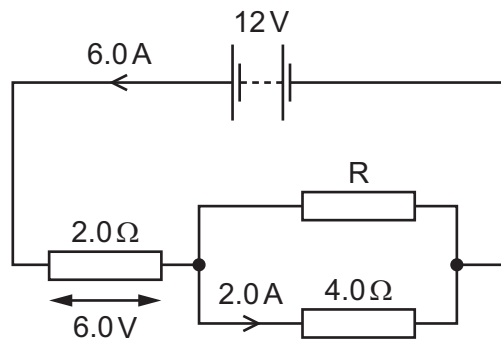

What is the current in resistor R and what is the p.d. across resistor R?

	current in resistor R/A	p.d. across resistor R/V
A	2.0	3.0
B	2.0	6.0
C	4.0	3.0
D	4.0	6.0

BLANK PAGE

BLANK PAGE

BLANK PAGE

Permission to reproduce items where third-party owned material protected by copyright is included has been sought and cleared where possible. Every reasonable effort has been made by the publisher (UCLES) to trace copyright holders, but if any items requiring clearance have unwittingly been included, the publisher will be pleased to make amends at the earliest possible opportunity.

To avoid the issue of disclosure of answer-related information to candidates, all copyright acknowledgements are reproduced online in the Cambridge International Examinations Copyright Acknowledgements Booklet. This is produced for each series of examinations and is freely available to download at www.cie.org.uk after the live examination series.

Cambridge International Examinations is part of the Cambridge Assessment Group. Cambridge Assessment is the brand name of University of Cambridge Local Examinations Syndicate (UCLES), which is itself a department of the University of Cambridge.

The Periodic Table of Elements

		Group														
I	II	III	IV	V	VI	VII	VIII									
3 Li lithium 7	4 Be beryllium 9	1 H hydrogen 1	5 B boron 11	6 C carbon 12	7 N nitrogen 14	8 O oxygen 16	9 F fluorine 19	10 Ne neon 20								
11 Na sodium 23	12 Mg magnesium 24	<div style="border: 1px solid black; padding: 5px; width: fit-content; margin: auto;"> Key atomic number atomic symbol name relative atomic mass </div>								13 Al aluminium 27	14 Si silicon 28	15 P phosphorus 31	16 S sulfur 32	17 Cl chlorine 35.5	18 Ar argon 40	
19 K potassium 39	20 Ca calcium 40									26 Fe iron 56	27 Co cobalt 59	28 Ni nickel 59	29 Cu copper 64	30 Zn zinc 65	31 Ga gallium 70	32 Ge germanium 73
37 Rb rubidium 85	38 Sr strontium 88	44 Ru ruthenium 101	45 Rh rhodium 103	46 Pd palladium 106	47 Ag silver 108	48 Cd cadmium 112	49 In indium 115	50 Sn tin 119	51 Sb antimony 122	52 Te tellurium 128	53 I iodine 127	54 Xe xenon 131				
55 Cs caesium 133	56 Ba barium 137	76 Os osmium 190	77 Ir iridium 192	78 Pt platinum 195	79 Au gold 197	80 Hg mercury 201	81 Tl thallium 204	82 Pb lead 207	83 Bi bismuth 209	84 Po polonium —	85 At astatine —	86 Rn radon —				
87 Fr francium —	88 Ra radium —	108 Hs hassium —	109 Mt meitnerium —	110 Ds darmstadtium —	111 Rg roentgenium —	112 Cn copernicium —	114 Fl flerovium —	116 Lv livermorium —								

57 La lanthanum 139	58 Ce cerium 140	59 Pr praseodymium 141	60 Nd neodymium 144	61 Pm promethium —	62 Sm samarium 150	63 Eu europium 152	64 Gd gadolinium 157	65 Tb terbium 159	66 Dy dysprosium 163	67 Ho holmium 165	68 Er erbium 167	69 Tm thulium 169	70 Yb ytterbium 173	71 Lu lutetium 175
89 Ac actinium —	90 Th thorium 232	91 Pa protactinium 231	92 U uranium 238	93 Np neptunium —	94 Pu plutonium —	95 Am americium —	96 Cm curium —	97 Bk berkelium —	98 Cf californium —	99 Es einsteinium —	100 Fm fermium —	101 Md mendelevium —	102 No nobelium —	103 Lr lawrencium —

lanthanoids

actinoids

The volume of one mole of any gas is 24 dm³ at room temperature and pressure (r.t.p.).