



Cambridge International Examinations
Cambridge International General Certificate of Secondary Education

COMBINED SCIENCE

0653/13

Paper 1 Multiple Choice

October/November 2016

45 minutes

Additional Materials: Multiple Choice Answer Sheet
 Soft clean eraser
 Soft pencil (type B or HB is recommended)

* 2 4 5 0 9 1 0 2 0 0 *

READ THESE INSTRUCTIONS FIRST

Write in soft pencil.
Do not use staples, paper clips, glue or correction fluid.
Write your name, Centre number and candidate number on the Answer Sheet in the spaces provided unless this has been done for you.
DO NOT WRITE IN ANY BARCODES.

There are **forty** questions on this paper. Answer **all** questions. For each question there are four possible answers **A, B, C** and **D**.
Choose the **one** you consider correct and record your choice in **soft pencil** on the separate Answer Sheet.

Read the instructions on the Answer Sheet very carefully.

Each correct answer will score one mark. A mark will not be deducted for a wrong answer.
Any rough working should be done in this booklet.
A copy of the Periodic Table is printed on page 20.
Electronic calculators may be used.

This document consists of **19** printed pages and **1** blank page.

- 1 In an experiment, two pins are pressed onto a student's hand. The student reports whether they feel one or two pins.

Which characteristic of living things is being investigated?

- A excretion
 B growth
 C respiration
 D sensitivity
- 2 How does carbon dioxide move out of the cells that form the walls of the alveoli into the surrounding air?
- A absorption
 B breathing
 C diffusion
 D respiration
- 3 The diagram shows a palisade cell from a leaf.

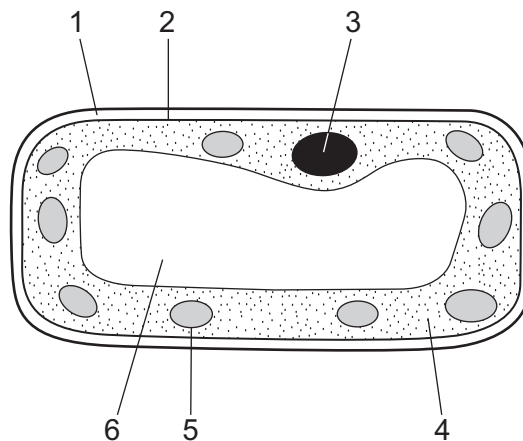

Which labelled structures are found only in plant cells?

- A 1, 2 and 6 B 1, 5 and 6 C 2, 3 and 5 D 2, 3 and 6
- 4 Which statements about enzymes are correct?
- 1 act as catalysts
 2 can be denatured by heat
 3 composed of complex carbohydrates
 4 produced by cells
- A 1, 2 and 4 B 1 and 4 only C 2, 3 and 4 D 3 and 4 only

5 When food reaches the stomach the digestion of starch stops.

Why is this?

- A All the starch has been digested.
- B The enzyme in saliva has been used up.
- C The pH in the stomach is very low.
- D The stomach does not produce a starch-digesting enzyme.

6 The photograph shows a sample of blood seen under a microscope.

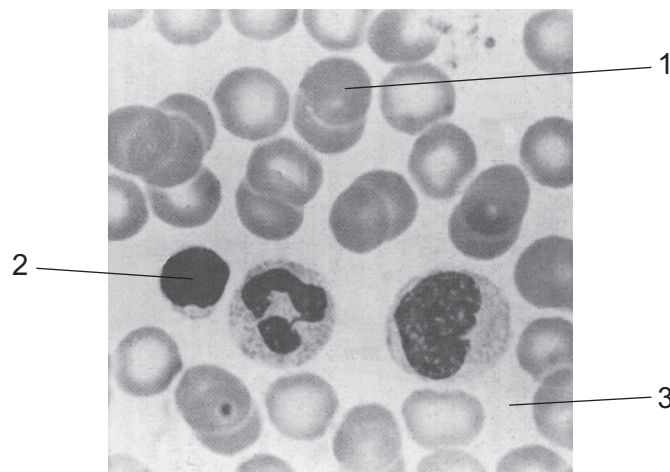

What is the name and function of one of the numbered parts in the blood?

	blood part		
	number	name	function
A	1	platelet	blood clotting
B	1	red blood cell	formation of antibodies
C	2	white blood cell	transport of oxygen
D	3	plasma	transport of hormones

- 7 The diagram shows a plant in a container of water. The layer of oil stops the water in the container evaporating.

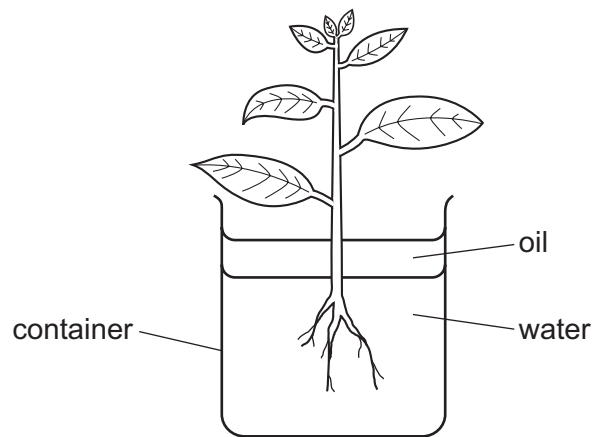

The initial mass of the container and contents is 296 g.

After two hours the mass of the container and contents is 292 g.

What is the rate of transpiration in this time?

- A** 150 g water/hour
B 148 g water/hour
C 4 g water/hour
D 2 g water/hour
- 8 What is the word equation for aerobic respiration?
- A** carbon dioxide + chlorophyll → glucose + oxygen
B carbon dioxide + glucose → oxygen + water
C glucose + oxygen → carbon dioxide + water
D oxygen + light energy → carbon dioxide + water
- 9 How does adrenaline affect blood glucose concentration and pulse rate?

	blood glucose concentration	pulse rate
A	decreases	decreases
B	decreases	increases
C	increases	decreases
D	increases	increases

10 The diagram shows a section through a flower.

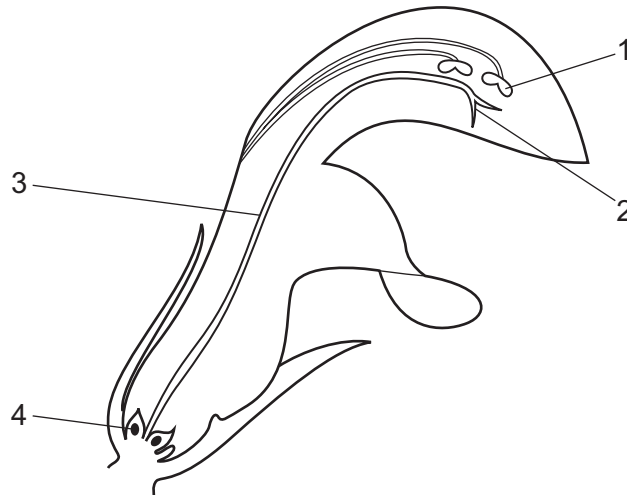

Which row in the table identifies male and female parts?

	male part	female part
A	1	2
B	2	4
C	3	1
D	4	3

11 The diagram shows the male reproductive system.

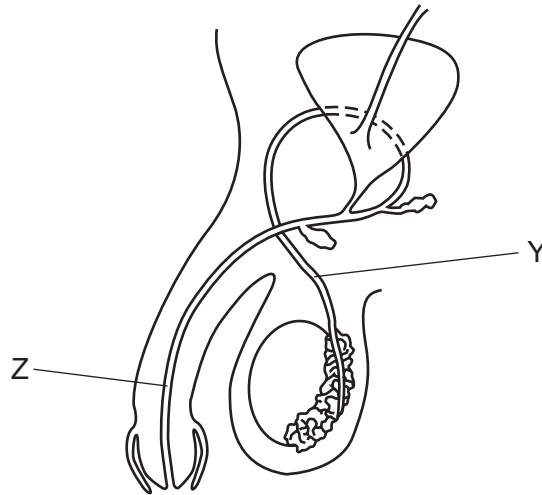

What are the parts Y and Z?

	Y	Z
A	prostate gland	urethra
B	urethra	prostate gland
C	sperm duct	prostate gland
D	sperm duct	urethra

12 The diagram shows part of the carbon cycle.

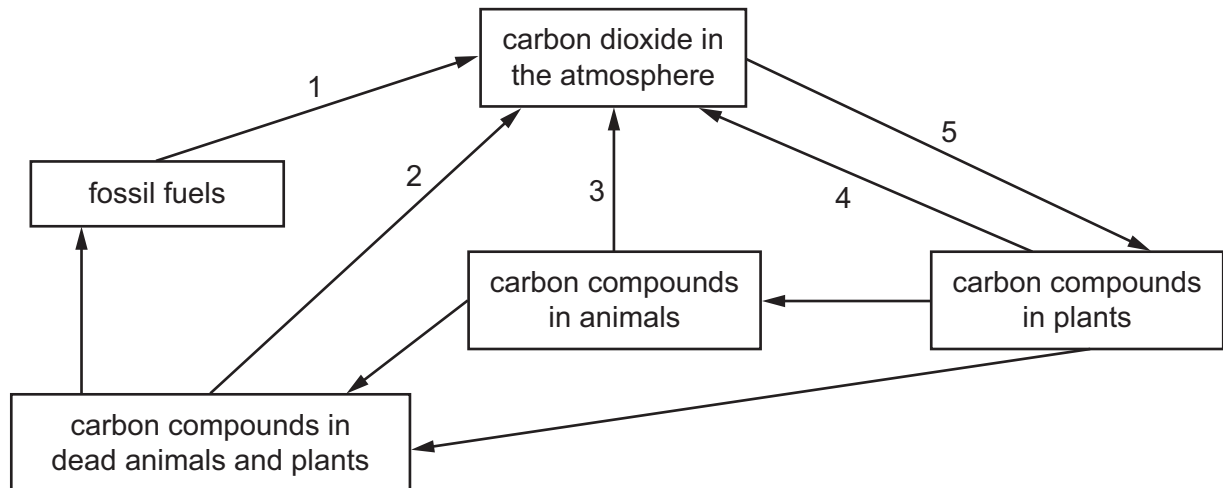

Which are stages that use oxygen and produce oxygen?

	uses oxygen	produces oxygen
A	1	2
B	2	3
C	3	4
D	4	5

13 Which are undesirable effects of deforestation?

- 1 build up of carbon dioxide in the air
- 2 extinction of species
- 3 loss of soil

- A** 1, 2 and 3
- B** 1 and 2 only
- C** 1 and 3 only
- D** 2 and 3 only

14 The diagrams show four different mixtures of gases.

Which diagram represents a mixture containing **only** elements?

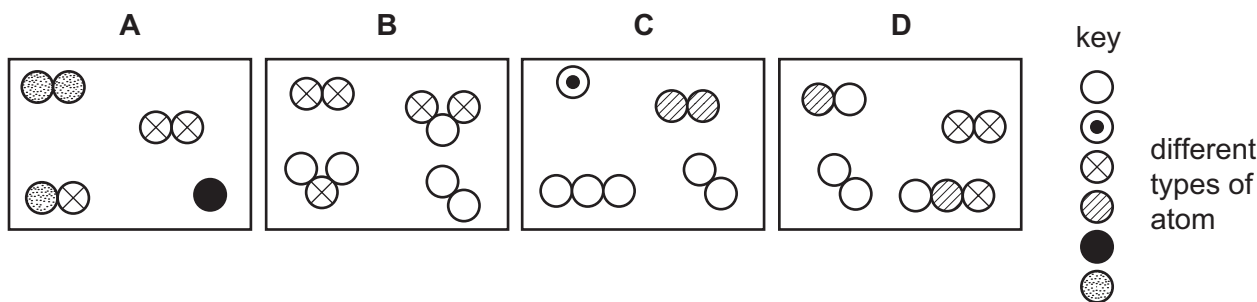

15 Four food samples W, X, Y and Z, are tested for additives P and Q using chromatography.

The chromatogram obtained is shown.

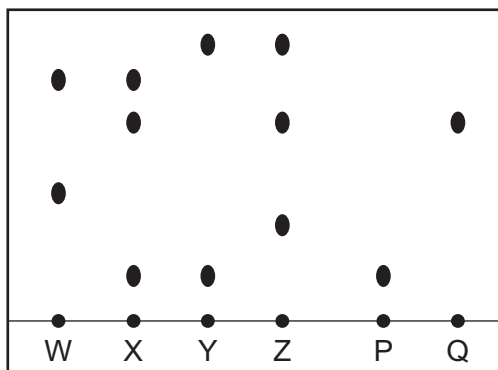

Which food sample does **not** contain artificial additives P or Q?

- A** W **B** X **C** Y **D** Z

16 Which number determines the order of elements in the Periodic Table?

- A** neutron number
B nucleon number
C proton number
D relative atomic mass

17 Which statement about compounds is correct?

- A** An ionic compound contains two metallic elements bonded together.
B In an ionic compound, metal ions are negatively charged.
C When metals combine with non-metals, electrons are shared between the atoms.
D When two non-metals combine, molecules are formed.

18 What does a word equation show?

	the changes that occur in a reaction	the speed of a reaction
A	✓	✓
B	✓	x
C	x	✓
D	x	x

19 Aqueous sodium chloride is electrolysed using the apparatus shown.

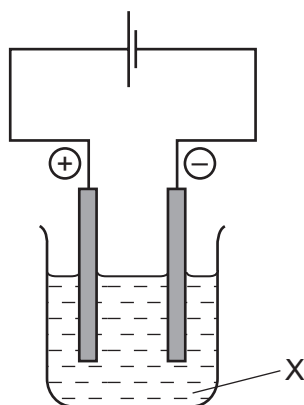

What is X?

- A** the anode
- B** the cathode
- C** the electrode
- D** the electrolyte

20 Which reaction is **most** endothermic?

	initial temperature / °C	final temperature / °C
A	18	23
B	19	18
C	20	22
D	21	19

21 Marble chips react with dilute hydrochloric acid producing carbon dioxide.

The progress of this reaction is followed using the apparatus shown.

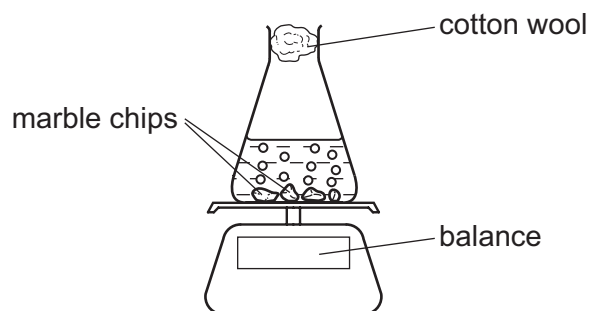

Which graph shows the results of this experiment?

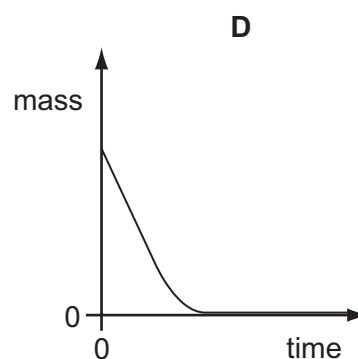
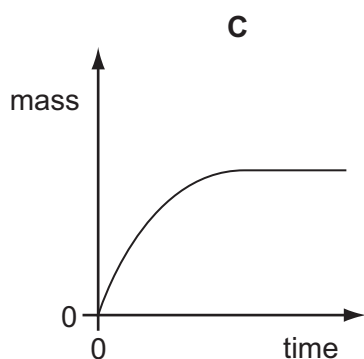
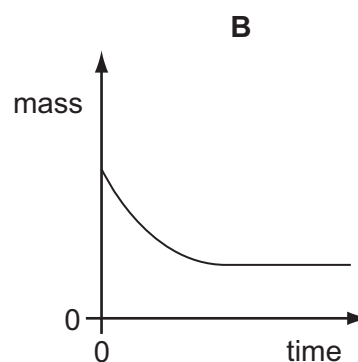
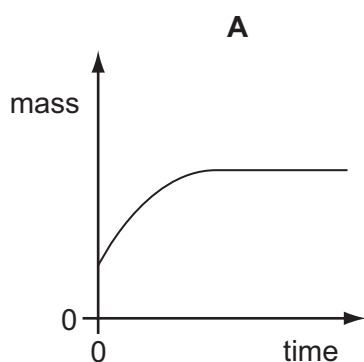

22 The word equation shows the reaction between substance J and hydrochloric acid.

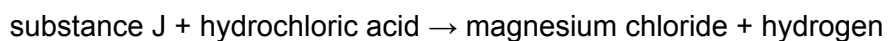

What is substance J?

- A magnesium
- B magnesium carbonate
- C magnesium hydroxide
- D magnesium oxide

- 23 A piece of damp blue litmus paper is placed in a gas.

The litmus paper turns red and then turns white.

What is the gas?

- A carbon dioxide
- B chlorine
- C hydrogen
- D oxygen

- 24 Period 3 of the Periodic Table is shown.

Na	Mg	Al	Si	P	S	Cl	Ar
----	----	----	----	---	---	----	----

Which statement about these elements is correct?

- A All the elements are metals.
 - B All the elements are non-metals.
 - C Metallic character decreases from Na to Ar.
 - D Proton number decreases from Na to Ar.
- 25 What is the order of reactivity of calcium, copper, potassium and zinc, from most to least reactive?
- A calcium, potassium, zinc, copper
 - B copper, zinc, calcium, potassium
 - C potassium, calcium, zinc, copper
 - D potassium, zinc, calcium, copper

26 A 100 cm³ sample of air is passed into the apparatus as shown.

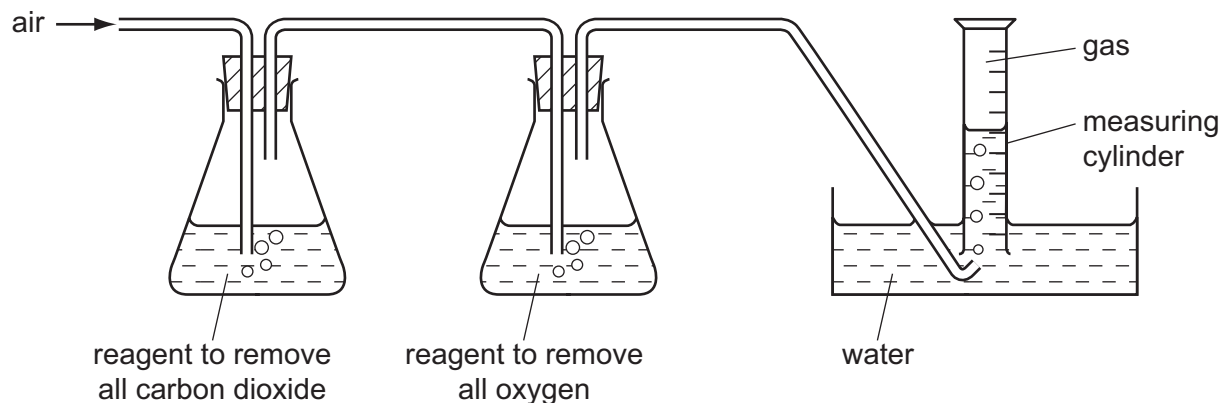

What is the volume and the composition of the gas collected in the measuring cylinder?

	volume / cm ³	composition
A	21	pure nitrogen
B	21	nitrogen and other gases
C	79	pure nitrogen
D	79	nitrogen and other gases

27 Substance X burns in air to form carbon dioxide and water.

What is substance X?

- A** a noble gas
- B** an alkane
- C** carbon
- D** hydrogen

28 Graph 1 is a distance/time graph. Graph 2 is a speed/time graph.

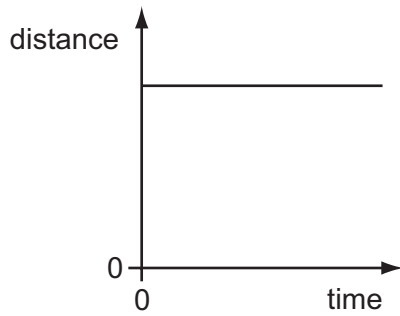

graph 1

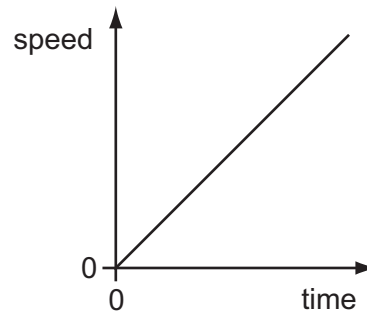

graph 2

Which, if any, of these graphs represents a car that is moving at constant speed?

- A graph 1 only
 - B graph 2 only
 - C both graphs
 - D neither graph
- 29 Which statement is **always** correct?
- A Smaller objects have less mass than larger objects.
 - B The mass of an object can change from one place to another.
 - C Weight and mass are both examples of a force.
 - D Weight on Earth is caused by the Earth's gravitational field.
- 30 A stone is dropped onto a soft surface. The stone does not bounce.

Which type of energy increases as the stone hits the surface?

- A chemical
- B gravitational (potential)
- C kinetic
- D thermal

31 A bowl contains some warm water. The water evaporates from the bowl.

Which row describes where the evaporation occurs and the effect of the evaporation on the temperature of the water left in the bowl?

	where evaporation occurs	effect on temperature of water in bowl
A	only on the surface	decreases
B	only on the surface	no change
C	throughout the water	decreases
D	throughout the water	no change

32 An engineer wants to fix a steel washer on to a steel rod. The rod is slightly too big to fit into the hole in the washer.

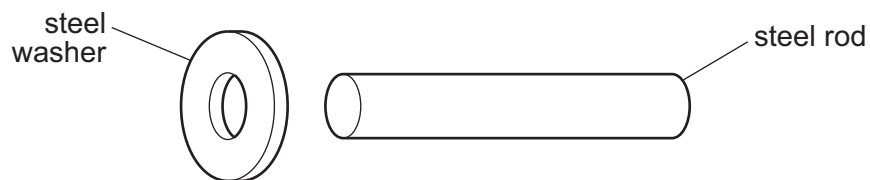

How can the engineer fit the washer on to the rod?

- A** Cool the washer and push it over the rod.
- B** Cool the washer and the rod to the same temperature and then push them together.
- C** Heat the rod and then push it in the hole.
- D** Heat the washer and then place it over the rod.

- 33 A man is in a cold room one metre away from a heater. The heater is switched on and the man feels warmer almost immediately.

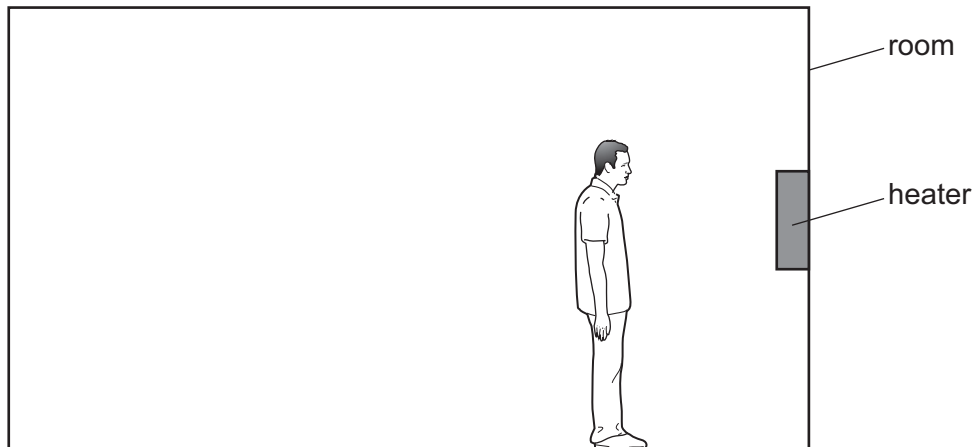

How is thermal energy transferred from the heater to the man so quickly?

- A by conduction only
 - B by convection only
 - C by radiation only
 - D by conduction, convection and radiation
- 34 The diagram represents a wave at one moment.

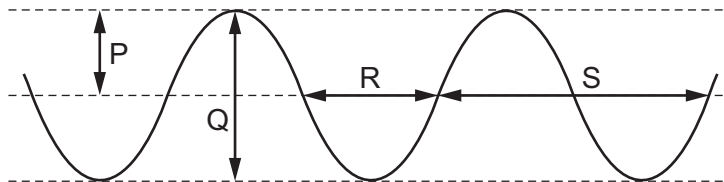

Which labelled arrows represent the amplitude and the wavelength of the wave?

	amplitude	wavelength
A	P	R
B	P	S
C	Q	R
D	Q	S

- 35** Two rectangular glass blocks are placed a short distance apart in air. A ray of light passes through the first block and enters the second block.

Which diagram shows the route taken by the light?

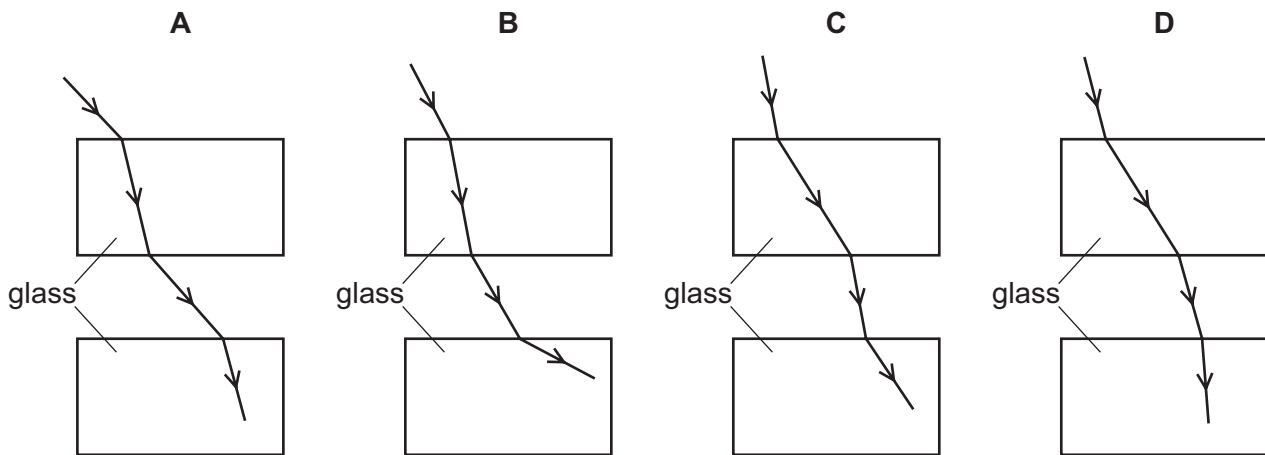

- 36** Which statement about the electromagnetic spectrum is correct?

- A** Gamma rays have the highest frequency.
- B** Microwaves have the smallest wavelength.
- C** Ultraviolet waves have the largest wavelength.
- D** Visible light has the lowest frequency.

- 37** Which change makes the pitch of a sound lower?

- A** decreasing its amplitude
- B** decreasing its frequency
- C** increasing its amplitude
- D** increasing its frequency

- 38 The diagrams show the circuits connected by four students to determine the resistance of a resistor R .

Which circuit is correct?

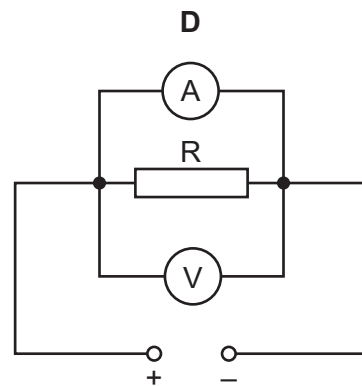
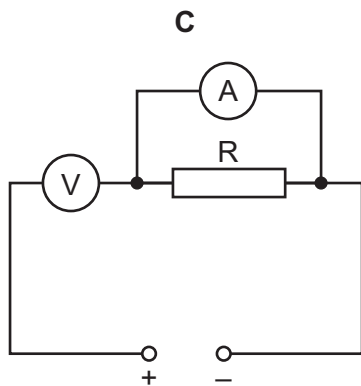
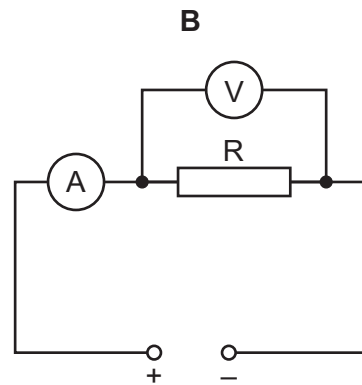
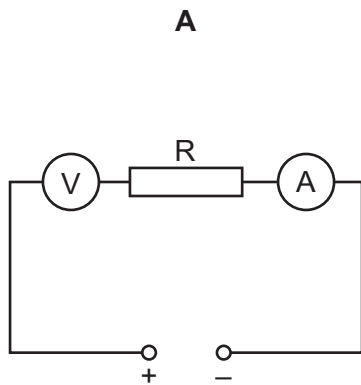

- 39 When a computer is switched on, the current rises quickly to 3.1 A and then falls slowly to a steady value of 1.0 A while the computer is in use.

The wire connecting the computer to the power supply can safely carry a current of up to 10.0 A.

The circuit contains a fuse.

Which value of fuse is suitable to use to provide the greatest protection?

- A** 1.0 A **B** 3.0 A **C** 5.0 A **D** 13.0 A

- 40 The circuit shows a lamp, four identical cells and four switches P, Q, R and S. All the switches are open.

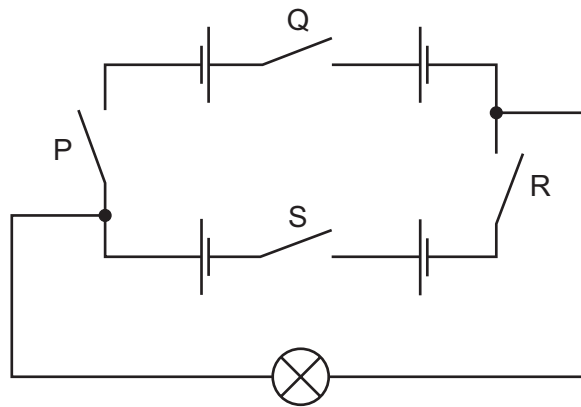

Two switches are now closed, and the lamp lights.

Which switches could have been closed to cause the lamp to light?

- A** P and R **B** Q and R **C** Q and S **D** R and S

BLANK PAGE

Permission to reproduce items where third-party owned material protected by copyright is included has been sought and cleared where possible. Every reasonable effort has been made by the publisher (UCLES) to trace copyright holders, but if any items requiring clearance have unwittingly been included, the publisher will be pleased to make amends at the earliest possible opportunity.

To avoid the issue of disclosure of answer-related information to candidates, all copyright acknowledgements are reproduced online in the Cambridge International Examinations Copyright Acknowledgements Booklet. This is produced for each series of examinations and is freely available to download at www.cie.org.uk after the live examination series.

Cambridge International Examinations is part of the Cambridge Assessment Group. Cambridge Assessment is the brand name of University of Cambridge Local Examinations Syndicate (UCLES), which is itself a department of the University of Cambridge.

