



Cambridge International Examinations
Cambridge International General Certificate of Secondary Education

CANDIDATE
NAME

CENTRE
NUMBER

--	--	--	--	--

CANDIDATE
NUMBER

--	--	--	--

*
6
1
4
9
4
7
3
6
0
1
*



COMBINED SCIENCE

0653/62

Paper 6 Alternative to Practical

October/November 2014

1 hour

Candidates answer on the Question Paper.

No Additional Materials are required.

READ THESE INSTRUCTIONS FIRST

Write your Centre number, candidate number and name on all the work you hand in.

Write in dark blue or black pen.

You may use an HB pencil for any diagrams or graphs.

Do not use staples, paper clips, glue or correction fluid.

DO NOT WRITE IN ANY BARCODES.

Answer **all** questions.

Electronic calculators may be used.

You may lose marks if you do not show your working or if you do not use appropriate units.

At the end of the examination, fasten all your work securely together.

The number of marks is given in brackets [] at the end of each question or part question.

This document consists of **16** printed pages.

1 A student is investigating the action of the enzyme amylase on starch.

- He measures 10 cm³ starch suspension into each of tubes **A** and **B** and places them in a water bath at 30 °C.
- He places tube **C**, which contains amylase solution, and tube **D**, which contains boiled amylase solution, into the water bath.
- He waits five minutes.
- During this time, he adds two drops of Reagent **X** to each of ten wells in a spotting tile as shown in Fig. 1.1

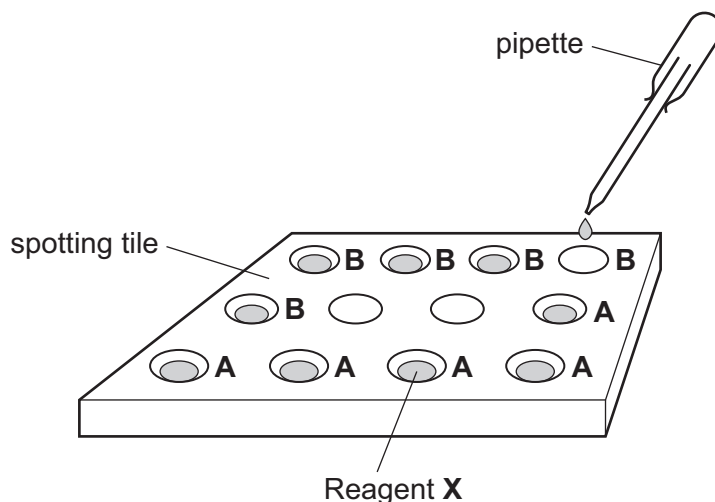

Fig. 1.1

- After 5 minutes he pours the contents of tube **C** into tube **A** and the contents of tube **D** into tube **B**.
- He then starts the stop-clock.
- Immediately, using a dropping pipette, he places 2 drops from tube **A** into one of the wells containing Reagent **X** in the spotting tile. He records in Table 1.1 the colour obtained.
- He repeats this with tube **B** into a different well containing Reagent **X**. He records in Table 1.1 the colour obtained.
- He repeats this procedure for tube **A** and tube **B** at 1 minute intervals for a further 4 minutes.

Table 1.1

time / minutes	colour of solution from tube A when added to Reagent X	colour of solution from tube B when added to Reagent X
0	<i>blue-black</i>	<i>blue-black</i>
1	<i>blue-black</i>	<i>blue-black</i>
2	<i>dark brown</i>	<i>blue-black</i>
3	<i>light brown</i>	<i>blue-black</i>
4	<i>light brown</i>	<i>blue-black</i>

(a) (i) Name Reagent **X**. [1]

(ii) By referring to the colours recorded in Table 1.1, state and explain what happens to the starch in tube **A** during the experiment.

.....
.....
..... [3]

(b) (i) Using the results in Table 1.1, state what can be concluded about the presence of starch in tube **B** at the end of the experiment.

..... [1]

(ii) Suggest an explanation for your conclusion in (b)(i).

.....
..... [1]

(c) Suggest **one** source of error for this experiment.

.....
..... [1]

(d) Suggest how you could change this method to investigate the effect of different temperatures on amylase activity.

.....
.....
..... [3]

2 A student is investigating the temperature changes when salts are dissolved in water.

- She measures 25 cm³ distilled water into a beaker.
- She uses a thermometer to find the temperature of the water, recording it in Table 2.1.
- She adds 2 g powdered sodium chloride to the water and stirs the mixture.
- She finds the temperature after 30 s and records it in Table 2.1.
- She washes out the beaker.
- She repeats the experiment using powdered anhydrous copper(II) sulfate.
- She repeats the experiment using powdered ammonium chloride.

Table 2.1

name of salt used	sodium chloride	copper(II) sulfate	ammonium chloride
initial temperature / °C	21.9	22.0	21.7
temperature / °C after 30 s	20.8		
change in temperature / °C			

(a) Suggest a reason why the samples of the salts used in the experiment are powdered before being added to the water.

.....
 [1]

(b) (i) Fig. 2.1 shows the thermometer scales for the temperatures after 30 s for copper(II) sulfate and ammonium chloride.

Read the temperatures and record them in Table 2.1.

[2]

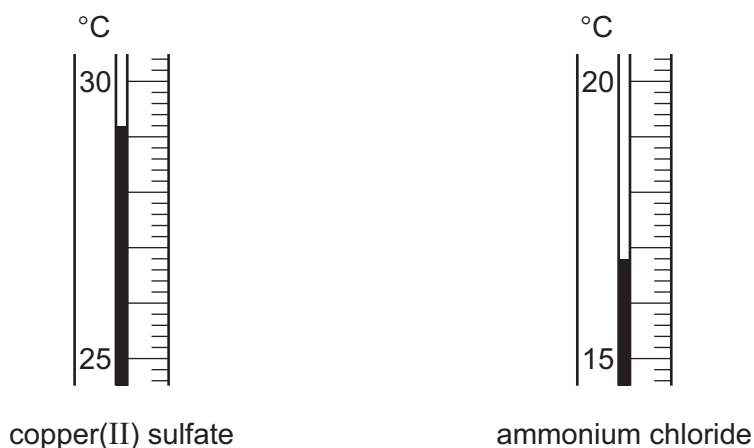

Fig. 2.1

(ii) Calculate the change in temperature for each of the salts.

Record the changes in Table 2.1.

Place a + sign in front of a temperature rise and a – sign in front of a temperature fall. [2]

(c) State the type of energy change observed for the dissolving of

copper(II) sulfate in water,

ammonium chloride in water. [2]

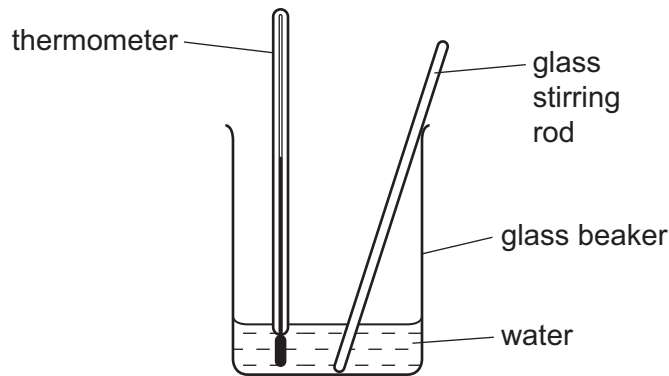

Fig. 2.2

(d) The student uses a glass beaker and a glass stirring rod, shown in Fig. 2.2, when dissolving the salts. She thinks that the results of the experiment can be made more accurate by modifying the apparatus.

Suggest **one** way that she can get a more accurate result for the temperature changes during the experiment.

.....
..... [1]

(e) The teacher says that when a solid salt is dissolved in water, energy is required to pull the ions of the solid away from each other. When new bonds are formed between the ions and the water molecules to make a solution, energy is given out.

Use this information to suggest an explanation for the temperature change that took place when copper(II) sulfate was dissolved in water, according to your answer in part (c).

.....
.....
.....
..... [2]

3 A student is carrying out an experiment to determine the density of a stone.

In **Part 1** of the experiment he finds out how the extension of a spring varies with the load.

In **Part 2** he finds the extension produced when the stone is hung on the spring in air and in water.

Part 1

- The student sets up the apparatus shown in Fig. 3.1 so that the pointer reads 0.0 cm when there is no mass attached to the spring.
- He hangs a 250 g mass on the spring and records the pointer reading.
- He replaces the 250 g mass by a 500 g mass and records the pointer reading.

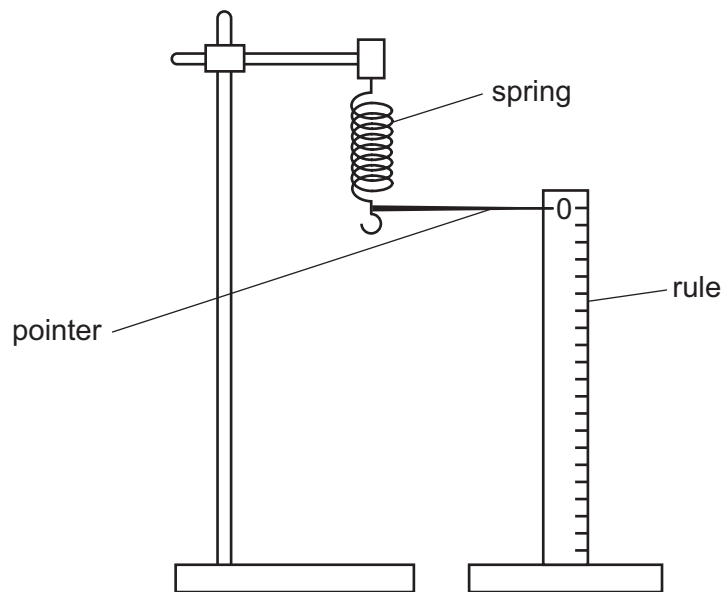

Fig. 3.1

Fig. 3.2 shows the pointer readings for the 250 g and 500 g masses.

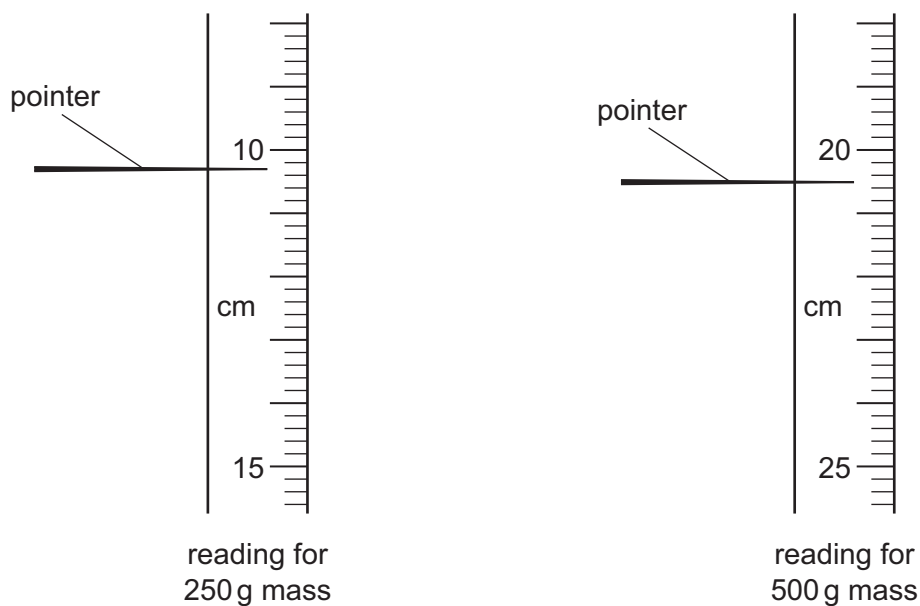

Fig. 3.2

Table 3.1

mass attached	position of pointer / cm
0	0.0
250 g	
500 g	

- (a) (i) Read to the nearest 0.1 cm the positions of the pointer in Fig. 3.2 for the 250 g and 500 g masses.

Record the readings in Table 3.1.

[2]

- (ii) Use the results in Table 3.1 to state how the extension of the spring varies with the load.

..... [1]

Part 2

- The student attaches a piece of wire to the stone and hangs it on the spring.
- He reads E_A the position of the pointer and records it in Table 3.2.
- He immerses the stone in a beaker of water as in Fig. 3.3.
- He reads E_w the new position of the pointer and records it in Table 3.2.

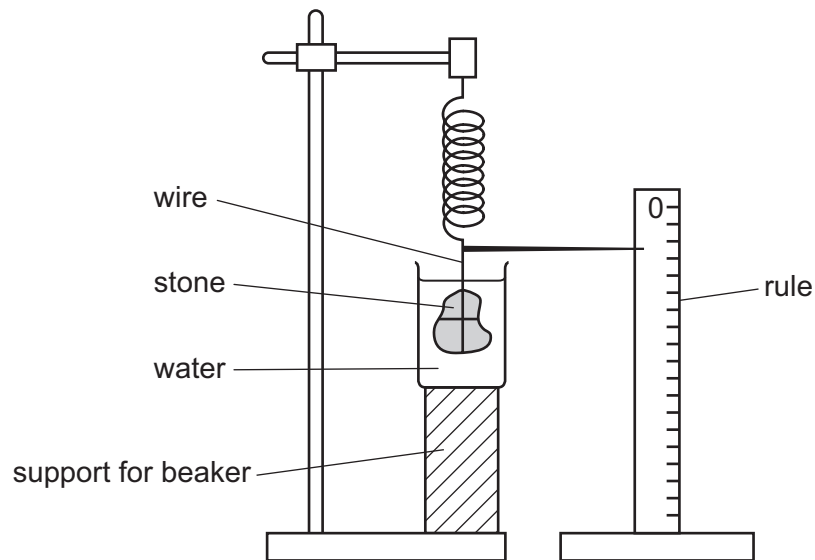

Fig. 3.3

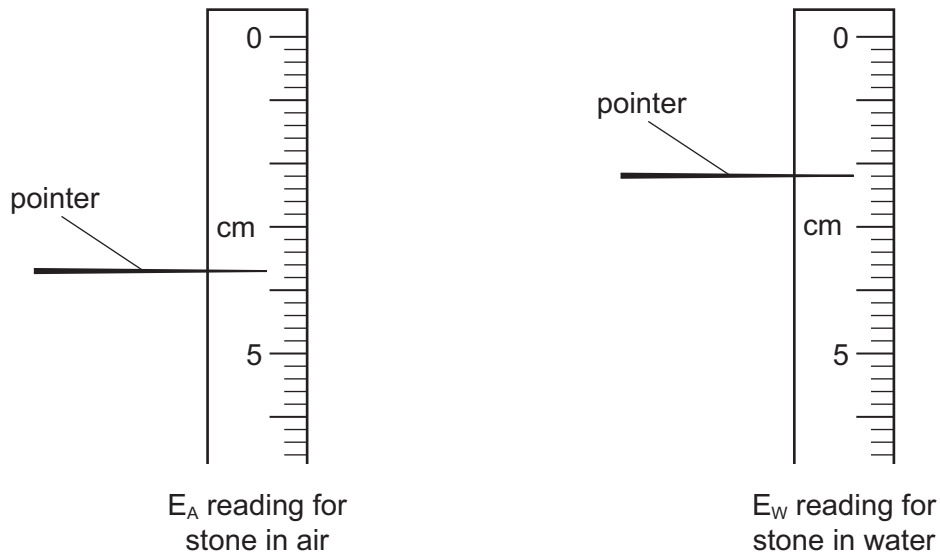

Fig. 3.4

Table 3.2

mass attached	position of pointer/cm
stone hanging in air	$E_A = \dots\dots\dots$
stone immersed in water	$E_W = \dots\dots\dots$

(b) Read to the nearest 0.1 cm the positions of the pointer in Fig. 3.4. Record the readings in Table 3.2. [2]

(c) (i) The teacher has given the student an equation for calculating the density of the stone.

Use the equation and data from Table 3.2, to calculate the density of the stone.

$$\text{density of the stone} = \frac{E_A}{(E_A - E_W)}$$

density of the stone = g/cm³ [1]

(ii) Compare the equation that you have used to calculate the density of the stone with the density equation $d = m/v$ to help you to complete this statement.

E_A is proportional to the of the stone. [1]

(iii) Compare the equation that you have used to calculate the density of the stone with the density equation $d = m/v$ to help you to complete this statement.

$(E_A - E_W)$ is proportional to the of the stone. [1]

(d) Suggest **two** reasons why the result may be slightly inaccurate when this method is used to find the density of the stone. Fig. 3.3 may help you.

.....
..... [2]

4 A student is investigating one of the characteristics of living things using insects.

She sets up the apparatus as shown in Fig. 4.1.

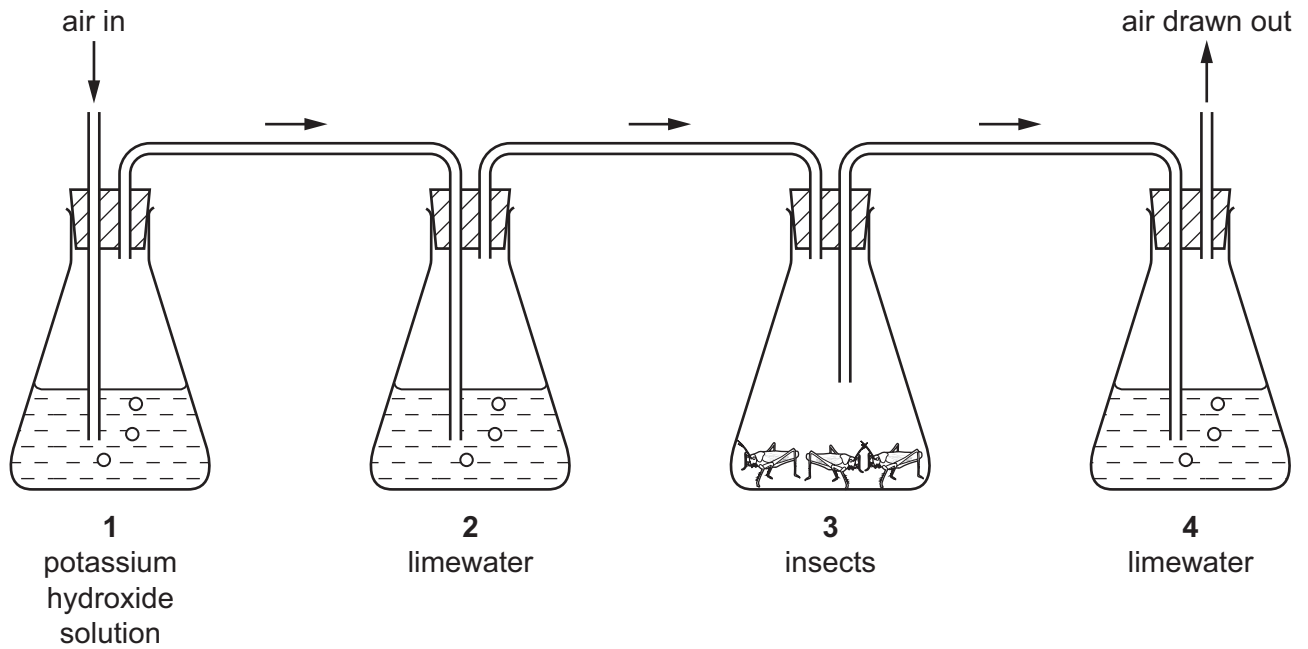

Fig. 4.1

Air is drawn through the apparatus from left to right as shown. The potassium hydroxide in flask 1 removes any carbon dioxide from the air.

(i) State the purpose of the limewater in flask 2.

..... [1]

(ii) Predict the appearance of the limewater in flask 2 after 10 minutes.

..... [1]

(b) (i) State the purpose of the limewater in flask 4.

..... [1]

(ii) Predict the appearance of the limewater in jar 4 after 10 minutes.

..... [1]

(c) Suggest a control for this experiment.

..... [1]

(d) (i) State the appearance of the liquid in flask 4 at the end of the experiment if it had contained water and Universal (full range) Indicator rather than the limewater.

.....
..... [1]

(ii) Explain your answer to **(d)(i)**.

.....
.....
..... [3]

(e) Name the process inside living cells that is responsible for the changes that are observed in this experiment.

..... [1]

- 5 A science student has been given a Test Plan to identify five metals. The Test Plan is shown on page 13.

The metals are calcium, iron, silver, zinc and magnesium. The small pieces of the metals are all grey or silver colour. The metals are labelled **A**, **B**, **C**, **D** and **E**.

The student has written some of his observations and conclusions.

Study the Test Plan and answer the questions below. **Do not write anything on the Test Plan.**

- (a) (i) Name the gas given off in Test 1.

..... [1]

- (ii) Explain how the student can test for the presence of this gas as it escapes from the test-tube and describe the positive result of this test.

.....
 [2]

- (b) (i) Name the white precipitate seen in observation 2b.

..... [1]

- (ii) Suggest the name of the solution formed when metal **B** reacts with cold water.

..... [1]

- (c) Name metal **A**. Use the observation in Test 3 to help you.

..... [1]

- (d) (i) Observation 5a tells the student that metal **C** is zinc.

Explain what he sees.

.....

 [2]

- (ii) Write the formula of the green precipitate that is seen in observation 5b.

..... [1]

- (e) Suggest what the student sees in Test 6 to tell him that metal **E** is silver.

..... [1]

TEST PLAN TO IDENTIFY FIVE METALS

Do not write anything on this page.

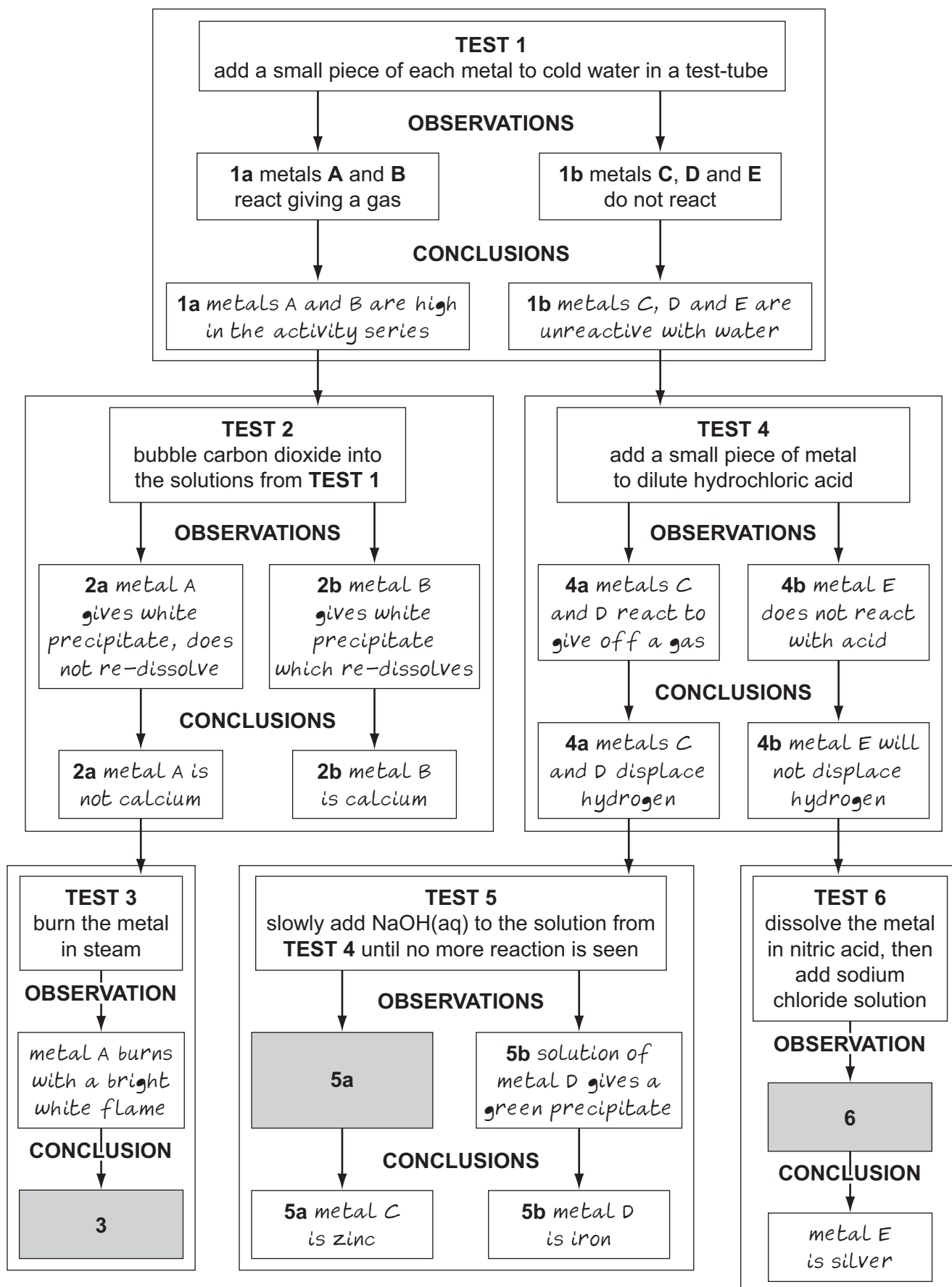

- 6 A student is testing the Law of Reflection which says that the angle of reflection is equal to the angle of incidence.

He is using a mirror made of polished stainless steel and a light source that creates a narrow beam. This is shown in Fig. 6.1.

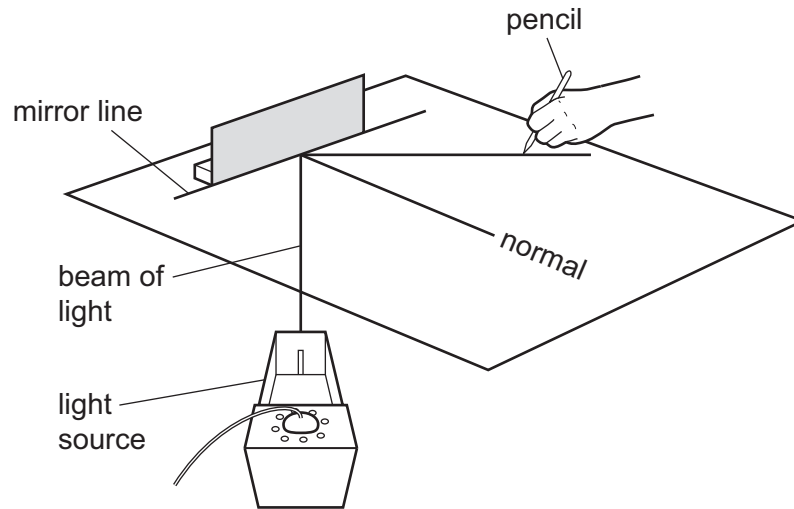

Fig. 6.1

Procedure

- The student draws a straight line on a piece of paper and labels it *mirror line*.
- He draws another line and labels it *normal*.
- He places the stainless steel mirror on the mirror line.
- He switches on the light source and arranges it so that its beam hits the mirror at the point where the normal meets the mirror line.
- Using a pencil, the student marks the incident and reflected beams of light.
- He removes the mirror and light source and then draws the incident and reflected rays. See Fig. 6.2.
- He measures two angles on the diagram.

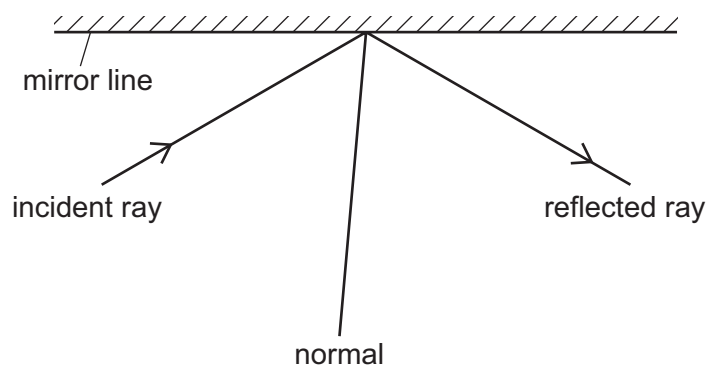

Fig. 6.2

(a) The student has measured two angles. He has written the following two statements.

A "The angle between the incident ray and the mirror line is equal to the angle between the reflected ray and the mirror line."

B "This proves that the Law of Reflection is obeyed."

(i) Use a protractor to measure the angle of incidence and the angle of reflection.

angle of incidence = degrees

angle of reflection = degrees [2]

(ii) Describe the student's mistake in drawing the diagram.

.....
 [1]

(iii) State and explain whether or not your measurements prove that the Law of reflection is obeyed.

.....
 [1]

(b) The student decides to test the same Law of Reflection using a mirror made from polished aluminium. He uses the same procedure as before, but he draws the normal line correctly.

Fig. 6.3 shows the result of this experiment. The student has used a pencil to mark the incident and reflected beams.

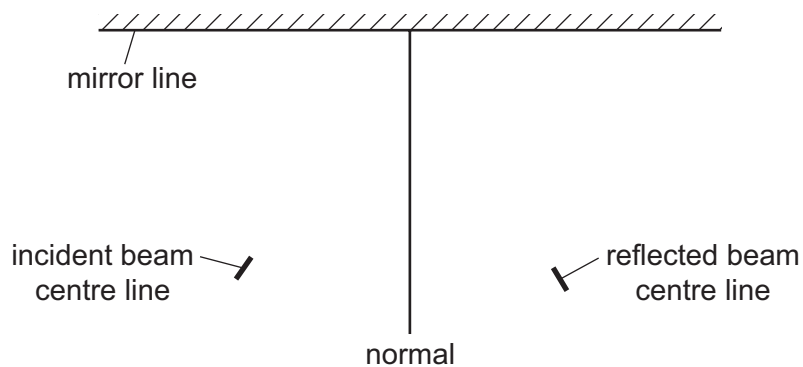

Fig. 6.3

(i) Complete Fig. 6.3 to show an incident ray and a reflected ray. [1]

(ii) Use a protractor to measure the angle of incidence and the angle of reflection.

angle of incidence = degrees

angle of reflection = degrees [2]

- (iii) The teacher tells the student that he has made mistakes in this experiment. As a result, the two angles are not equal.

Suggest a mistake that the student may have made when he

placed the mirror on the paper,

.....

drew the incident beam and reflected beam lines on the paper.

..... [2]

- (c) The experiments use a solid metal and a solid metal alloy as reflective surfaces. The student states that solid metals reflect light because of the free movement of particles within them.

Suggest the name of these particles. [1]

Permission to reproduce items where third-party owned material protected by copyright is included has been sought and cleared where possible. Every reasonable effort has been made by the publisher (UCLES) to trace copyright holders, but if any items requiring clearance have unwittingly been included, the publisher will be pleased to make amends at the earliest possible opportunity.

Cambridge International Examinations is part of the Cambridge Assessment Group. Cambridge Assessment is the brand name of University of Cambridge Local Examinations Syndicate (UCLES), which is itself a department of the University of Cambridge.