



Cambridge IGCSE™

CANDIDATE
NAME

CENTRE
NUMBER

--	--	--	--	--

CANDIDATE
NUMBER

--	--	--	--

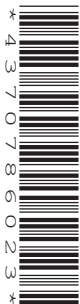

COMBINED SCIENCE

0653/63

Paper 6 Alternative to Practical

May/June 2022

1 hour

You must answer on the question paper.

No additional materials are needed.

INSTRUCTIONS

- Answer **all** questions.
- Use a black or dark blue pen. You may use an HB pencil for any diagrams or graphs.
- Write your name, centre number and candidate number in the boxes at the top of the page.
- Write your answer to each question in the space provided.
- Do **not** use an erasable pen or correction fluid.
- Do **not** write on any bar codes.
- You may use a calculator.
- You should show all your working and use appropriate units.

INFORMATION

- The total mark for this paper is 40.
- The number of marks for each question or part question is shown in brackets [].

This document has **12** pages. Any blank pages are indicated.

1 A student investigates the effect of oxygen concentration on the germination of cress seeds.

Procedure

The student:

- puts 12 cress seeds into each of five trays
- adds some water to each tray
- puts each tray into a sealed bag, each bag contains a different concentration of oxygen
- places the trays the same distance from the same lamp
- counts the number of seeds that have germinated after two weeks.

The results are shown in Table 1.1.

Table 1.1

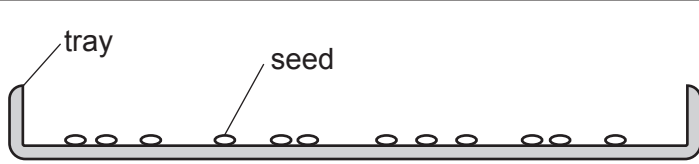
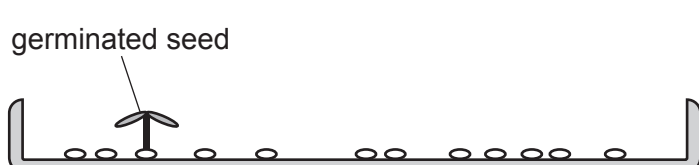
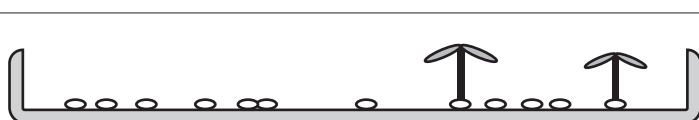
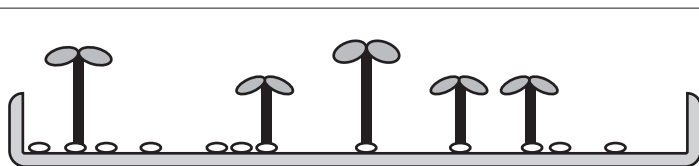
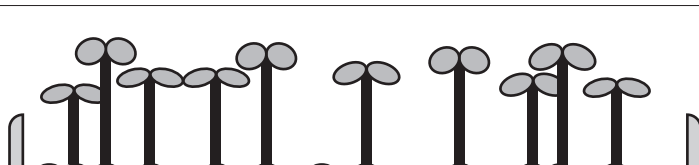
percentage oxygen concentration in bag	tray of seeds	number of seeds germinated	percentage of seeds germinated
0		0	0
2		1	8.3
5		2
10		41.7
20		83.3

(a) Complete Table 1.1 by counting the number of seeds germinated at 10% and 20% oxygen concentrations. [1]

(b) Calculate the percentage of seeds that have germinated at 5% oxygen concentration.

Use the equation shown.

$$\text{percentage of seeds germinated} = \frac{\text{number of seeds germinated}}{\text{total number of seeds in tray}} \times 100$$

Record your answer in Table 1.1. [1]

(c) (i) On the grid, plot a graph of the percentage of seeds germinated (vertical axis) against the percentage oxygen concentration.

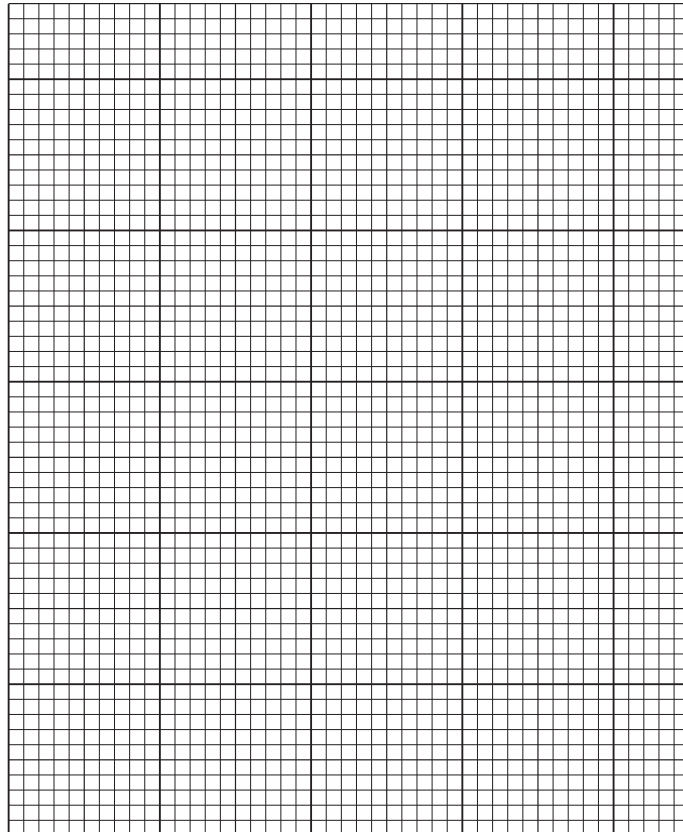

[3]

(ii) Draw the line of best fit. [1]

(iii) State the relationship between the oxygen concentration and the number of seeds germinated.

.....
..... [1]

(d) Describe one **other** effect increasing oxygen concentration has on the seeds shown in Table 1.1.

.....
..... [1]

(e) (i) Suggest why the student uses 12 seeds in each tray instead of just one seed.

.....
..... [1]

(ii) Suggest **two** improvements to the procedure.

Do **not** include changing the number of seeds.

1

.....

2

..... [2]

(f) Identify **one** factor that the student keeps constant in this investigation.

.....
..... [1]

(g) The student wants to find out if the germinating seeds make carbon dioxide.

State the test to confirm the presence of carbon dioxide and give the observation for a positive result.

test

observation

[1]

[Total: 13]

BLANK PAGE

2 A student investigates some reactions of zinc metal.

Procedure

The student:

- sets up the apparatus shown in Fig. 2.1

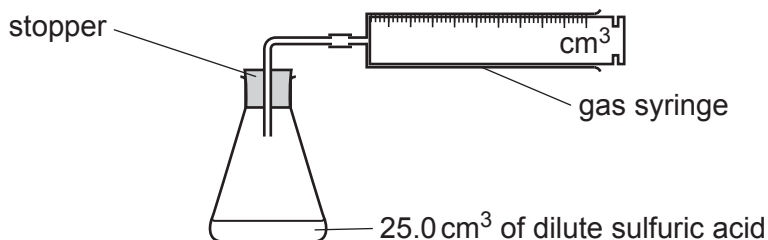

Fig. 2.1

- removes the stopper and adds 1.0 g of zinc powder to the flask
- quickly replaces the stopper and immediately starts a stop-watch
- measures the total volume of gas collected in the gas syringe during the first 20 seconds of the reaction.

The student repeats the procedure using 1.0 g of zinc powder mixed with 0.1 g of iron powder.

(a) Fig. 2.2 shows the readings on the gas syringe for each experiment.

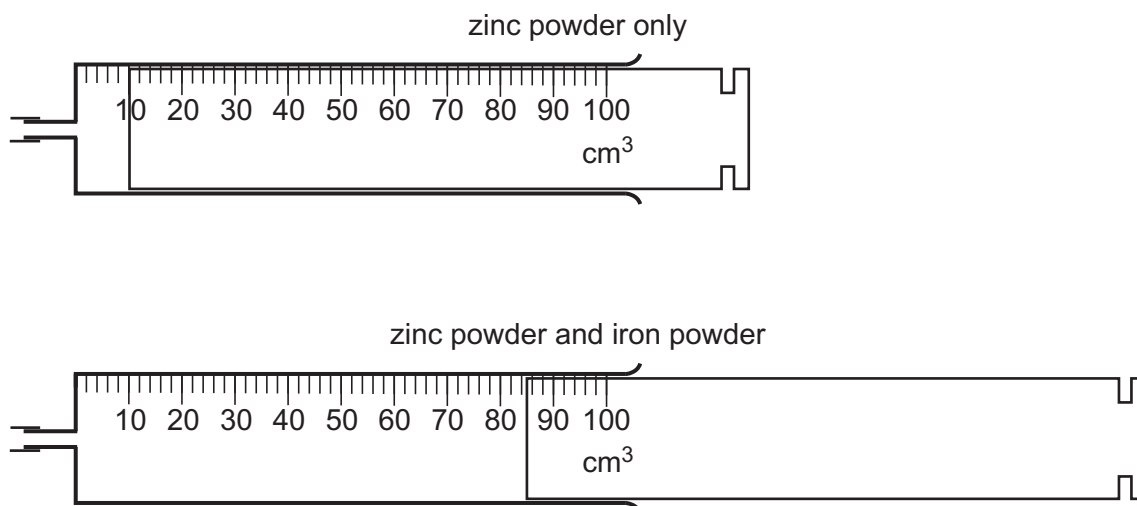

Fig. 2.2

(i) Record the volume of gas collected in each experiment in cm^3 , to the nearest cm^3 .

zinc powder only cm^3
 zinc powder and iron powder cm^3
 [2]

- (ii) The rate of this reaction is calculated using the equation shown.

$$\text{rate} = \frac{\text{volume of gas collected}}{20}$$

Calculate the rate of reaction in each experiment.

rate of reaction with zinc powder only = cm³/s

rate of reaction with zinc powder and iron powder = cm³/s
[2]

- (iii) Identify which experiment has the fastest rate of reaction.

Explain your answer.

.....
..... [1]

- (iv) Suggest why the student is **not** able to collect all the gas made in the first 20 seconds.

.....
..... [1]

- (b) The student places a lighted splint into the gas made in this experiment.

The gas makes a squeaky pop.

Name the gas.

..... [1]

[Total: 7]

3 Zinc reacts with aqueous iron(II) sulfate as shown in the word equation.

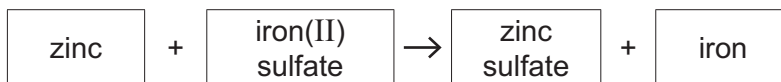

The reaction is exothermic because it releases energy and makes the temperature of the reaction mixture increase.

Plan an investigation to find the relationship between the mass of zinc added to aqueous iron(II) sulfate and the temperature increase of the reaction mixture.

You are provided with:

- aqueous iron(II) sulfate
- zinc powder.

You may use any common laboratory apparatus in your plan.

In your plan, include:

- the apparatus needed
- a brief description of the method and an explanation of any safety precautions you will take
- what you will measure
- which variables you will keep constant
- how you will process your results to draw a conclusion.

You may include a labelled diagram if you wish.

You may include a table that can be used to record the results if you wish.

.....

.....

.....

.....

.....

.....

.....

.....

.....

.....

.....

.....

.....

.....

.....

.....

.....

.....

.....

.....

.....

..... [7]

- 4 A student investigates the resistance of two identical lamps connected in series. The student assembles the circuit shown in Fig. 4.1.

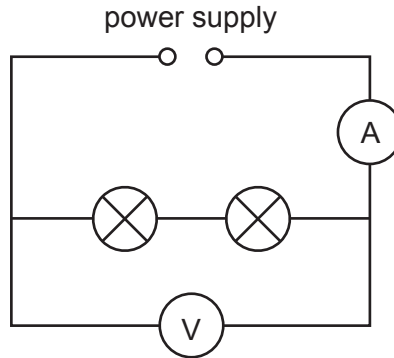

Fig. 4.1

- (a) (i) Fig. 4.2 shows the voltmeter and ammeter readings.

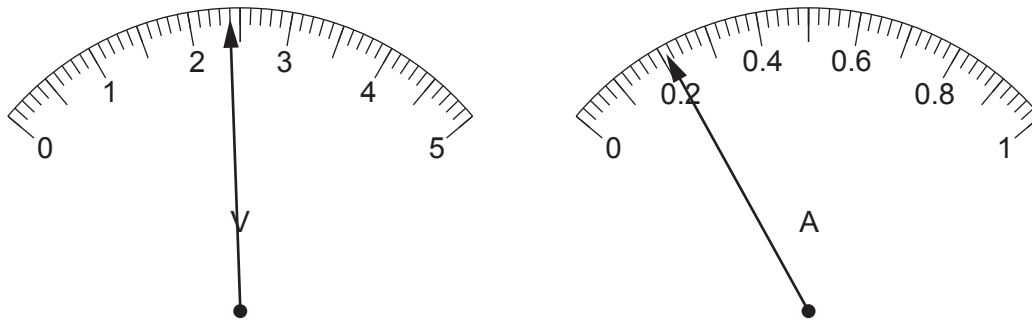

Fig. 4.2

Record the potential difference (p.d.) V_1 across both lamps and the current I_1 in the circuit.

$V_1 = \dots\dots\dots$ V

$I_1 = \dots\dots\dots$ A
[2]

- (ii) Calculate the total resistance R_s of the two identical lamps.

Use the equation shown.

$$R_s = \frac{V_1}{I_1}$$

$R_s = \dots\dots\dots$ Ω [1]

(b) After a few minutes one of the lamps breaks.

(i) State what the student observes.

.....
..... [1]

(ii) Describe how the student uses some of the components in Fig. 4.1 to find out which lamp still works.

.....
.....
..... [2]

(c) The student replaces the broken lamp and rearranges the circuit in Fig. 4.1 so that:

- the lamps are connected in parallel
- the ammeter still measures the total current in the circuit
- the voltmeter measures the p.d. across both lamps.

(i) Complete Fig. 4.3 to show this new circuit.

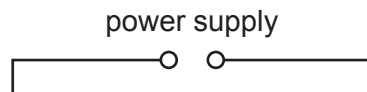

Fig. 4.3

[3]

(ii) A switch can be added to the circuit in (c)(i) to control both lamps. Mark with an **X** on your circuit in (c)(i) the position of a switch that controls both lamps. [1]

(d) In the parallel circuit in (c)(i) the meter readings are:

$$V_2 = 2.4 \text{ V}$$

$$I_2 = 0.84 \text{ A}$$

(i) Calculate the total resistance R_p of the lamps in this circuit.

Give your answer to **two** significant figures.

$$R_p = \dots\dots\dots \Omega \text{ [2]}$$

(ii) Describe how the brightness of the lamps in the parallel circuit is different from the lamps in the series circuit in Fig. 4.1.

.....
 [1]

[Total: 13]

Permission to reproduce items where third-party owned material protected by copyright is included has been sought and cleared where possible. Every reasonable effort has been made by the publisher (UCLES) to trace copyright holders, but if any items requiring clearance have unwittingly been included, the publisher will be pleased to make amends at the earliest possible opportunity.

To avoid the issue of disclosure of answer-related information to candidates, all copyright acknowledgements are reproduced online in the Cambridge Assessment International Education Copyright Acknowledgements Booklet. This is produced for each series of examinations and is freely available to download at www.cambridgeinternational.org after the live examination series.

Cambridge Assessment International Education is part of Cambridge Assessment. Cambridge Assessment is the brand name of the University of Cambridge Local Examinations Syndicate (UCLES), which is a department of the University of Cambridge.