



Cambridge International Examinations
Cambridge International General Certificate of Secondary Education

CANDIDATE
NAME

CENTRE
NUMBER

--	--	--	--	--

CANDIDATE
NUMBER

--	--	--	--



COMBINED SCIENCE

0653/63

Paper 6 Alternative to Practical

May/June 2017

1 hour

Candidates answer on the Question Paper.

No Additional Materials are required.

READ THESE INSTRUCTIONS FIRST

Write your Centre number, candidate number and name on all the work you hand in.

Write in dark blue or black pen.

You may use an HB pencil for any diagrams or graphs.

Do not use staples, paper clips, glue or correction fluid.

DO NOT WRITE IN ANY BARCODES.

Answer **all** questions.

Electronic calculators may be used.

You may lose marks if you do not show your working or if you do not use appropriate units.

At the end of the examination, fasten all your work securely together.

The number of marks is given in brackets [] at the end of each question or part question.

This document consists of **18** printed pages and **2** blank pages.

BLANK PAGE

- 1 A student investigates the production of gas by yeast cells.
- He adds some yeast suspension to a large test-tube and places the test-tube in a water-bath at 35 °C.
 - He adds 5 g of sucrose to the test-tube and stirs well.
 - He attaches a delivery tube to the large test-tube and collects the gas produced in an inverted measuring cylinder as shown in Fig. 1.1.

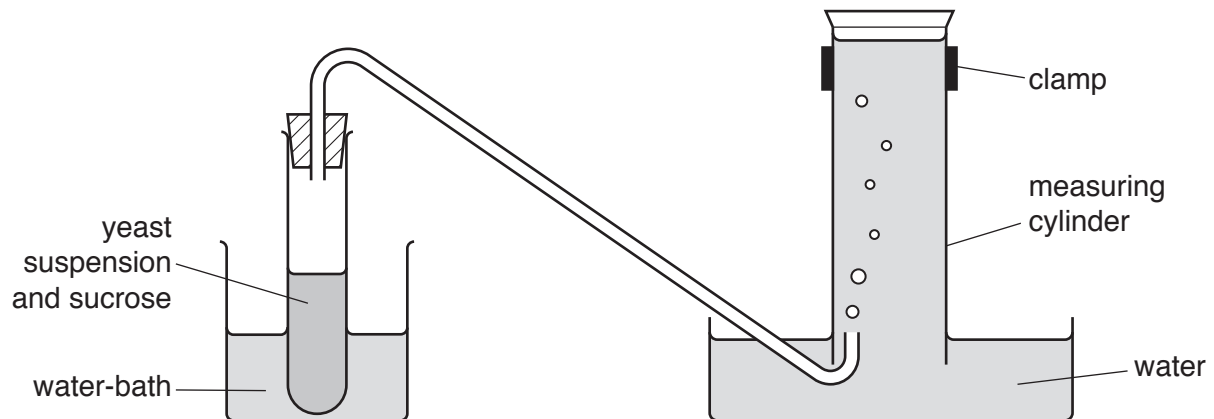

Fig. 1.1

- He starts the stopclock and measures the volume of gas collected to the nearest 0.1 cm³ every 2 minutes for 10 minutes.

His measurements are shown in Table 1.1.

Table 1.1

time/minutes	volume of gas collected/cm ³
0	0.0
2	0.5
4	1.5
6	6.2
8	
10	

(a) Read the volumes of gas in the measuring cylinder in Fig. 1.2.

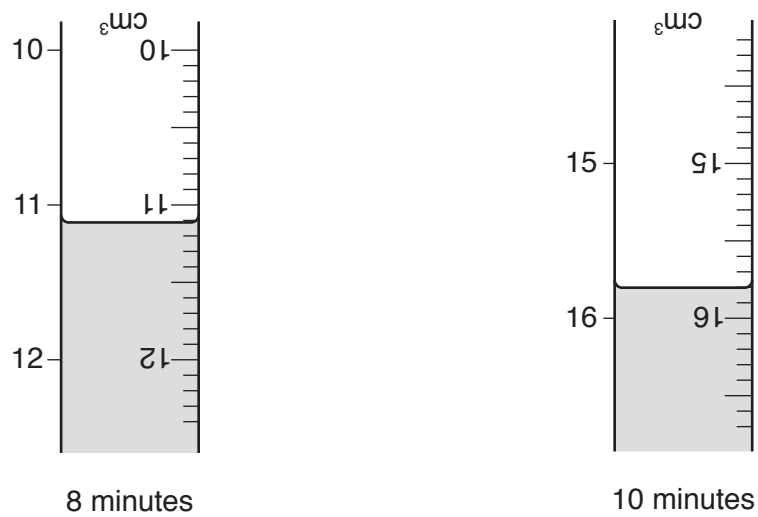

Fig. 1.2

Record these values in Table 1.1.

[2]

(b) On the grid provided, plot a graph of the volume of gas produced (vertical axis) against time.

Draw the best-fit line.

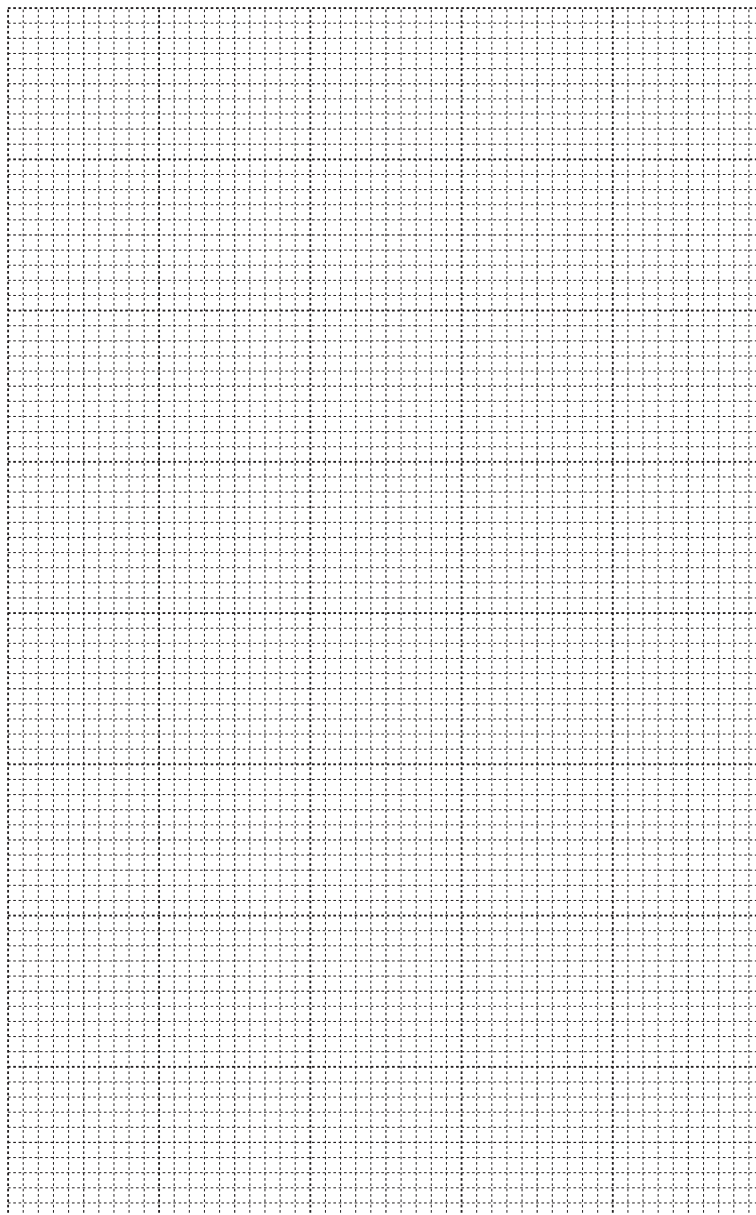

[4]

(c) The student empties the measuring cylinder. He adds limewater to the measuring cylinder and shakes it for a few seconds. The limewater turns milky.

(i) Name the gas identified by this test.

.....[1]

(ii) Name the process in yeast cells that produces this gas.

.....[1]

(d) Another student wants to investigate the effect of the amount of sucrose on the production of gas by yeast. She carries out the same experiment but uses **only half** the amount of sucrose.

(i) Predict, by adding a new line to your graph in (b), how this would change the volume of gas collected. Label this new line **S**. [1]

(ii) State **one** variable that the student needs to keep constant.

.....[1]

Please turn over for Question 2.

2 A student has to identify compounds **H** and **J**. Compound **J** is a solution of a sulfate and has the same cation as solid **H**.

- (a)
- She strongly heats a test-tube containing **H**.
 - The gas produced is bubbled through a delivery tube into limewater.
 - She removes the delivery tube from the limewater before she stops heating.
- (i) Complete Fig. 2.1 to show the apparatus when it is connected together.
Label the apparatus and the chemicals.

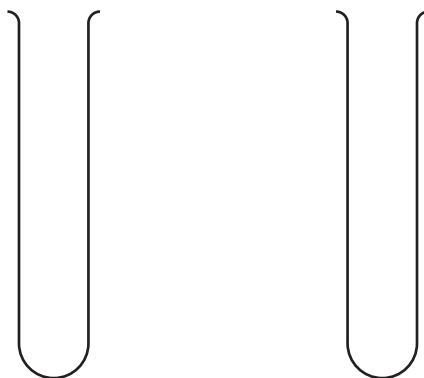

Fig. 2.1.

[2]

- (ii) Explain why it is important that the student removes the delivery tube from the limewater before she stops heating.

.....
[1]

- (iii) Her observations are shown below.

appearance of solid:

green solid changes to a black solid

appearance of limewater:

colourless solution becomes milky

State what these observations tell you about the identity of **H**.

.....
[1]

- (b) • She places solution **J** (which is blue in colour) in a large test-tube and adds an **excess** of sodium hydroxide solution.
- She stirs well and then filters the mixture.

Her description of the filtrate **F**, and the residue **R**, is shown below.

F colourless

R blue

Use the information in (a)(iii) and (b) to identify **H** and **J**.

H is

J is

[2]

- (c) She heats **R**, the residue from (b), in a test-tube. She observes that steam and a black solid are produced.

During this reaction **R** changes into compound **K**.

K contains the same cation as **H**.

K also forms when **H** is heated in (a).

Identify **K**.

Compound **K** is[1]

- (d) Filtrate **F** in (b) should be a mixture of sodium sulfate and sodium hydroxide. Suggest how the presence of the sulfate ion can be confirmed.

.....

.....[1]

- (e) A student carries out the test in (b) using zinc sulfate solution instead of solution **J**.

- (i) State what the student observes during the test.

.....

.....[1]

- (ii) Explain why no residue is seen when the mixture is filtered.

.....

.....[1]

- 3 A student measures the focal length, f , of a convex lens using the experimental set-up shown in Fig. 3.1.

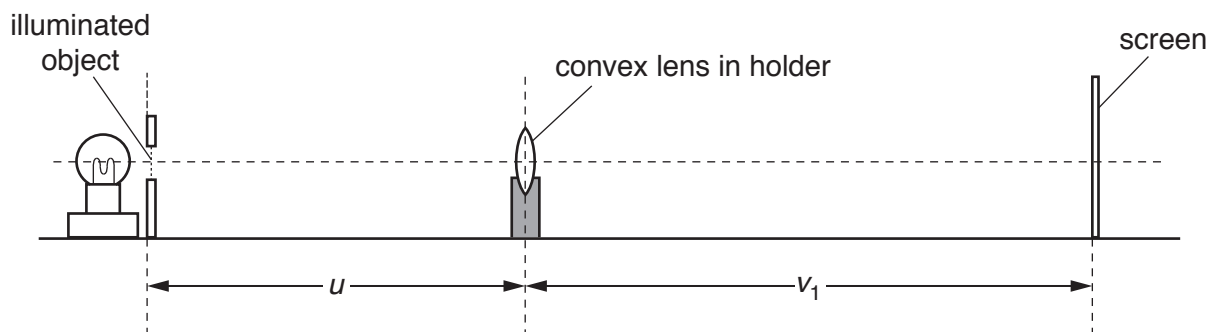

Fig. 3.1

He places the lens a distance $u=25.0$ cm from the illuminated object. He adjusts the position of the screen by moving it backwards and forwards along the bench, until a sharp image of the illuminated object is formed on the screen.

- (a) (i) On Fig. 3.1, measure, to the nearest 0.1 cm, the image distance v_1 from the lens to the screen.

$v_1 = \dots\dots\dots$ cm [1]

- (ii) Fig. 3.1 is drawn one-fifth full size. Calculate the actual image distance v from the lens to the screen.

Write your answer in Table 3.1.

[1]

- (iii) The student repeats the procedure described above for values of u of 35.0 cm, 45.0 cm, 55.0 cm and 65.0 cm.

His results are shown in Table 3.1.

Table 3.1

object distance u /cm	image distance v /cm	$y = \frac{1000}{u} / \frac{1}{\text{cm}}$	$x = \frac{1000}{v} / \frac{1}{\text{cm}}$
25.0			
35.0	26.2	28.6	38.2
45.0	22.6	22.2	44.2
55.0	20.5	18.2	48.8
65.0	19.4	15.4	51.5

Complete Table 3.1 by filling in the remaining values of y (where $y = \frac{1000}{u}$) and x (where $x = \frac{1000}{v}$).

Write your values of y and x to one decimal place. [1]

(b) State **one** precaution that the student should take while carrying out the experiment to ensure that the readings he obtains are as accurate as possible.

.....
[1]

(c) (i) On the grid provided, plot a graph of y (vertical axis) against x . **Start the x-axis from zero.**
 Draw the best-fit straight line.

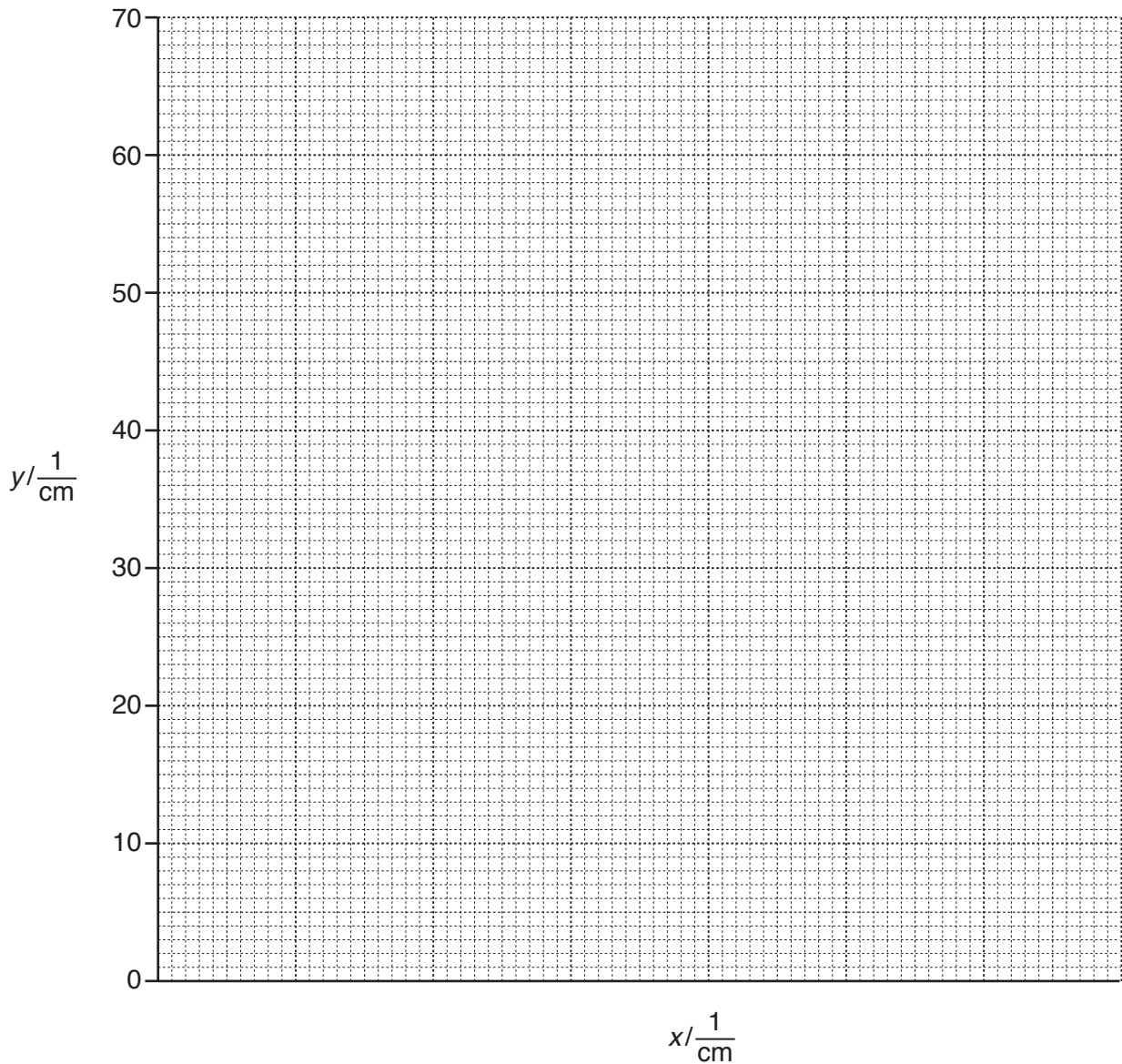

[3]

- (ii) Use your graph to determine the intercept your line makes with the y -axis.

You may need to extend your graph line until it cuts the y -axis.

intercept = [1]

- (iii) The focal length, f , of the lens is given by the equation shown.

$$f = \frac{1000}{\text{intercept}}$$

Calculate the focal length of the lens.

$f = \dots\dots\dots$ cm [2]

4 A student investigates the effect of temperature on the growth of germinated seeds.

- She takes several seeds that have been allowed to germinate.
- She places some of the germinated seeds onto some cotton wool in dish **A**.
- She repeats for dishes **B** and **C**.
- She places dish **A** in a room at 5 °C,
dish **B** in a room at 15 °C,
and dish **C** in a room at 25 °C.
- After two days she measures the height of the shoots.

(a) State **two** conditions or substances that the seeds need in order to germinate.

1

2

[2]

(b) State how the student can make sure the shoots of the germinated seeds grow **vertically** upwards.

.....[1]

(c) Predict the appearance of the germinated seeds after the two days by drawing **one** shoot in each dish.

Draw these shoots in Fig. 4.1.

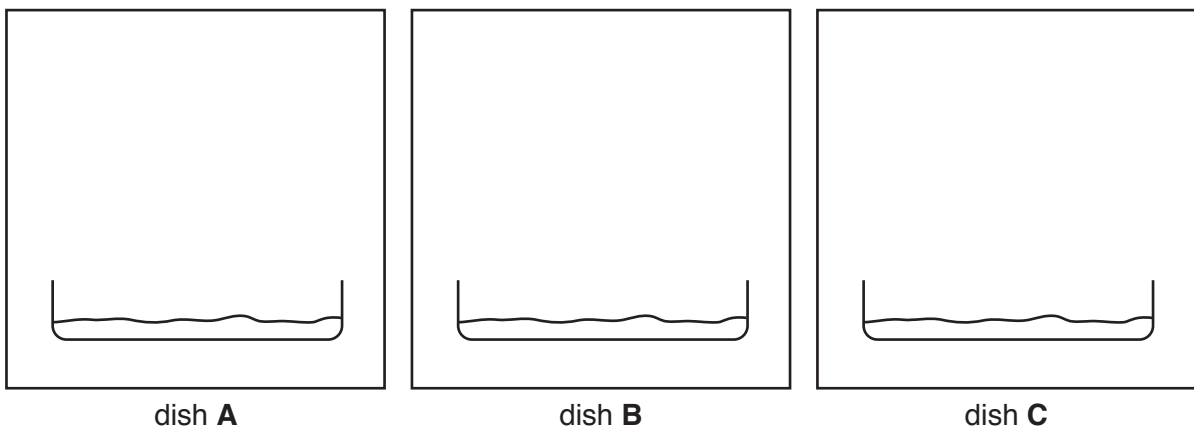

Fig. 4.1

[3]

(d) Describe how she could test for the presence of reducing sugar. Include the observation for a positive result.

method

.....

.....

observation

.....

[3]

(e) Suggest why the student used more than one germinating seed in each dish.

.....[1]

5 A student investigates the effect of surface area of a solid on the rate of reaction.

He uses the apparatus shown in Fig. 5.1.

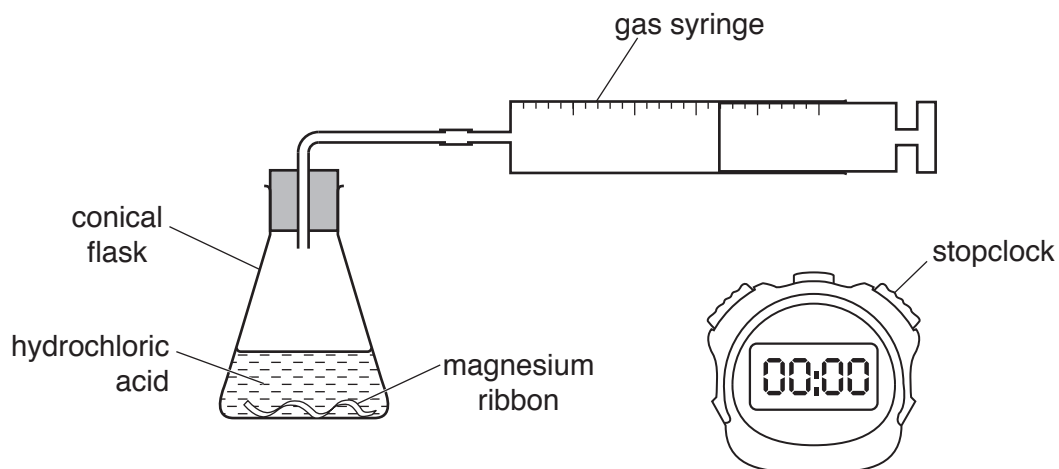

Fig. 5.1

- (a)
1. He places one 3 cm piece of magnesium ribbon into the conical flask.
 2. He adds 25 cm³ of hydrochloric acid.
 3. He connects the flask to the gas syringe and starts the stopclock.

List the measurements he should record in this experiment.

.....

.....

.....

.....[2]

(b) He repeats the steps in (a) but uses **two** 3 cm pieces of magnesium ribbon instead of one piece.

(i) State how the observations and measurements he makes are different from those in (a).

observations

.....

measurements

.....

[2]

(ii) Suggest how the student should continue the experiment to obtain a more reliable conclusion about the effect of surface area of a solid on the rate of reaction.

.....

.....

..... [2]

(iii) State **two** factors, other than the volume of hydrochloric acid, which must be kept constant throughout the investigation.

1

2

[2]

(c) Name the gas produced in this reaction and describe the test to confirm its identity.

name of gas

test to confirm identity

.....

[2]

6 A student investigates energy transfer.

He attaches a mass onto a piece of string which is attached to a clamp.

He lays a rough cloth on the bench and places a ball bearing, with a diameter of 6 mm, onto the cloth next to the hanging mass as shown in Fig. 6.1.

He places a metre rule on the cloth alongside the ball bearing so that the ball bearing is at the 0 cm mark.

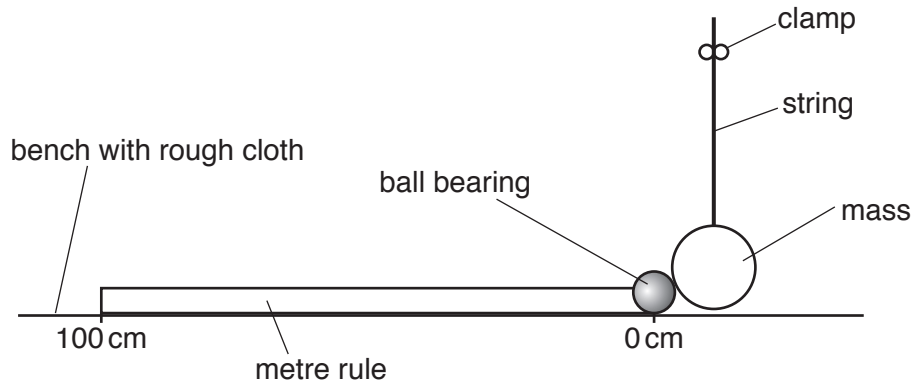

Fig. 6.1

He pulls the mass to the side to make an angle $\theta = 10^\circ$ as shown in Fig. 6.2.

He lets go of the mass and as it swings down it hits the ball bearing which moves to the left as shown in Fig. 6.3.

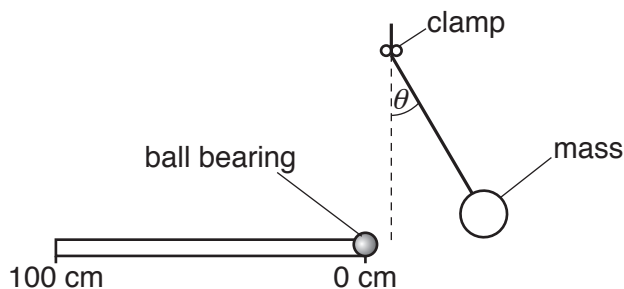

Fig. 6.2

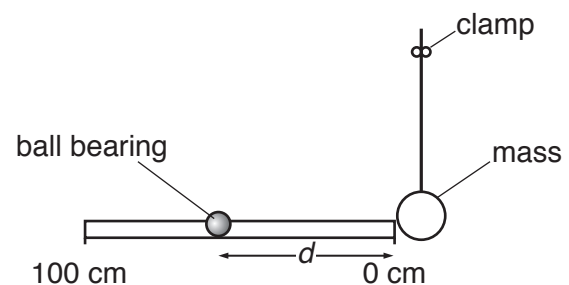

Fig. 6.3

He measures the distance d travelled by the ball bearing.

He repeats the experiment for angles $\theta = 20^\circ, 30^\circ, 40^\circ, 50^\circ, 60^\circ$ and 70° .

(a) Fig. 6.4 shows the distance travelled by the ball bearing at $\theta = 20^\circ$.

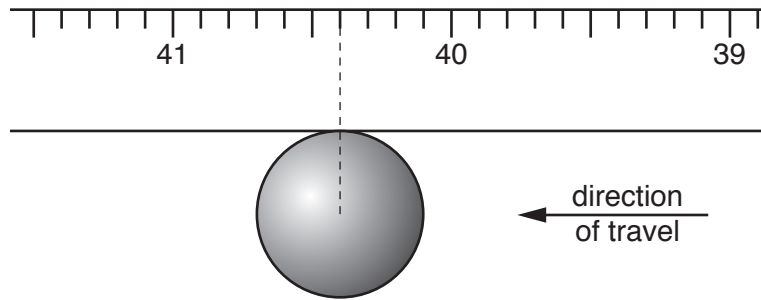

Fig. 6.4

Read the distance on the metre rule and record it in Table 6.1.

Table 6.1

angle $\theta / ^\circ$	distance / cm
10	20.3
20	
30	59.2
40	56.2
50	88.0
60	91.9
70	95.4

[1]

(b) The student plotted his results onto a graph as shown in Fig. 6.5.

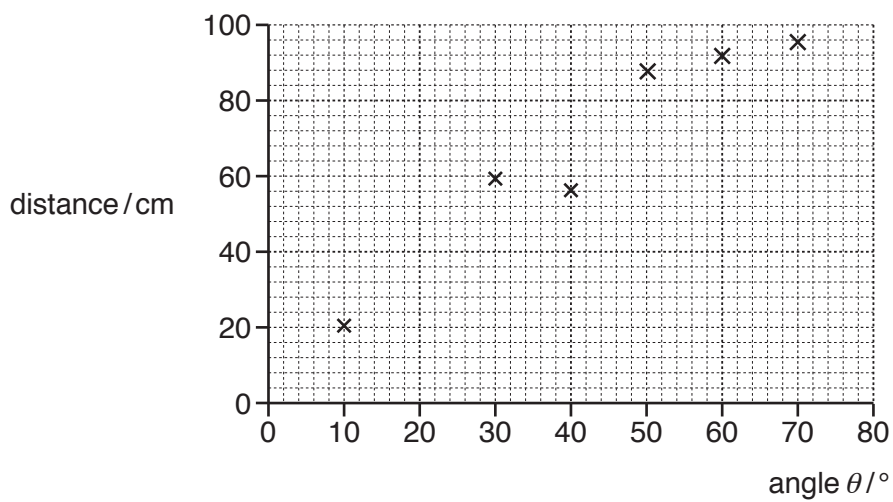

Fig. 6.5

- (i) Plot the point at $\theta = 20^\circ$.

Draw a line of best-fit.

[2]

- (ii) Use your graph to describe in detail the relationship between the angle θ and the distance moved by the ball bearing.

.....
.....
.....[2]

- (c) Another student carries out a similar experiment to investigate how the distance moved by the ball bearing changes as the diameter of the ball bearing changes.

State the changes that he should make to this experiment. Include the diameters of the ball bearings to be used.

.....
.....
.....
.....
.....[3]

- (d) In these experiments, some of the energy of the mass transfers to the ball bearing.

- (i) Complete the sentence by adding the names of the energies involved in the transformation.

The energy of the mass transfers to
..... energy of the ball bearing.
[1]

- (ii) Suggest why this experiment is carried out on a rough cloth instead of the surface of the bench.

.....
.....[1]

BLANK PAGE

Permission to reproduce items where third-party owned material protected by copyright is included has been sought and cleared where possible. Every reasonable effort has been made by the publisher (UCLES) to trace copyright holders, but if any items requiring clearance have unwittingly been included, the publisher will be pleased to make amends at the earliest possible opportunity.

To avoid the issue of disclosure of answer-related information to candidates, all copyright acknowledgements are reproduced online in the Cambridge International Examinations Copyright Acknowledgements Booklet. This is produced for each series of examinations and is freely available to download at www.cie.org.uk after the live examination series.

Cambridge International Examinations is part of the Cambridge Assessment Group. Cambridge Assessment is the brand name of University of Cambridge Local Examinations Syndicate (UCLES), which is itself a department of the University of Cambridge.