



Cambridge IGCSE™

COMBINED SCIENCE

0653/22

Paper 2 Multiple Choice (Extended)

February/March 2021

45 minutes

You must answer on the multiple choice answer sheet.

You will need: Multiple choice answer sheet
Soft clean eraser
Soft pencil (type B or HB is recommended)

INSTRUCTIONS

- There are **forty** questions on this paper. Answer **all** questions.
- For each question there are four possible answers **A**, **B**, **C** and **D**. Choose the **one** you consider correct and record your choice in soft pencil on the multiple choice answer sheet.
- Follow the instructions on the multiple choice answer sheet.
- Write in soft pencil.
- Write your name, centre number and candidate number on the multiple choice answer sheet in the spaces provided unless this has been done for you.
- Do **not** use correction fluid.
- Do **not** write on any bar codes.
- You may use a calculator.

INFORMATION

- The total mark for this paper is 40.
- Each correct answer will score one mark.
- Any rough working should be done on this question paper.
- The Periodic Table is printed in the question paper.

This document has **20** pages. Any blank pages are indicated.



1 What are the characteristics of living organisms?

	excretion	growth	movement	nutrition	reproduction	respiration	sensitivity / response
A	✓	✓	✓	✓	✓	✓	✓
B	✓	✓	x	✓	✓	✓	✓
C	✓	x	x	✓	x	✓	✓
D	x	✓	✓	✓	✓	✓	x

2 The diagram shows a plant cell.

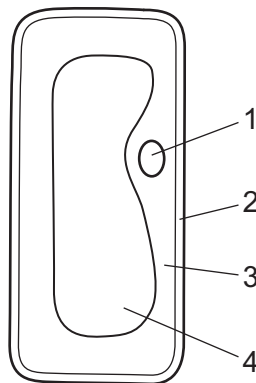

Which structures are also found in an animal cell?

- A** 1 and 3 **B** 1 and 4 **C** 2 and 3 **D** 2 and 4

3 An animal cell is placed in a solution with a water potential lower than its cytoplasm.

Which statement correctly describes the movement of water across the cell membrane?

- A** equal movement in and out of the cell
B net movement into the cell
C net movement out of the cell
D no movement in or out of the cell

4 Which graph shows the effects of pH on the activity of an enzyme?

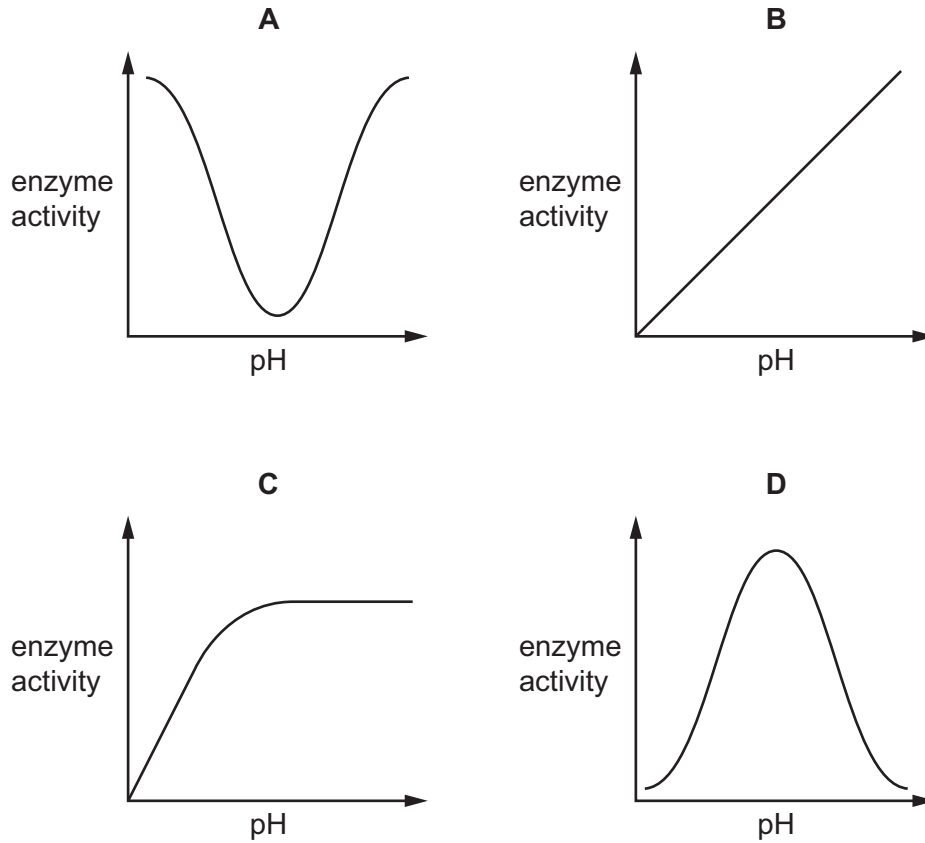

5 The diagram shows a section of a leaf.

Which letter is the epidermis?

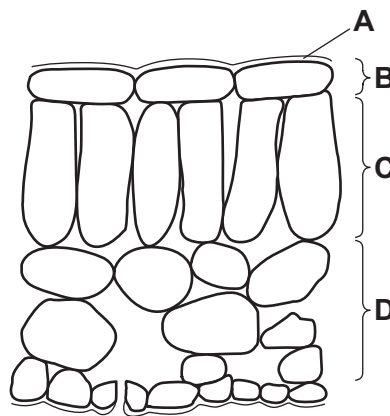

6 What does a lack of iron in the diet cause?

- A bleeding from the gums
- B constipation
- C less oxygen transported to cells
- D weakening of bones

7 Which diagram represents the digestion of food molecules in the alimentary canal?

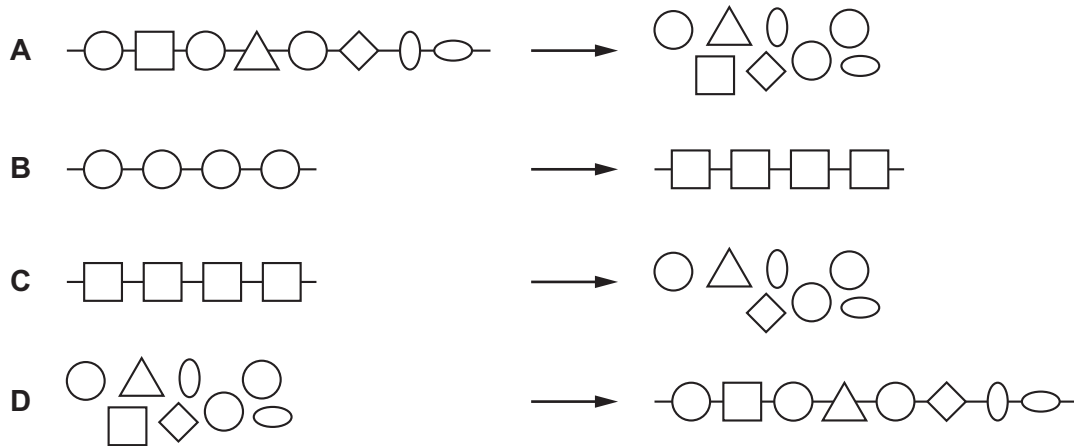

8 Which statement explains why the rate of transpiration changes on a hot dry day?

- A** a decrease in diffusion of water vapour through the stomata
- B** a decrease in evaporation of water vapour through the stomata
- C** an increase in evaporation of water from the mesophyll cells
- D** a decrease in diffusion of water from the mesophyll cells

9 What are the functions of the cilia and mucus in the gas exchange system of mammals?





	cilia	mucus
A	make mucus	trap pathogens
B	make mucus	move cilia
C	move mucus	trap pathogens
D	move mucus	move cilia

10 The table shows some data recorded by a scientist about a student.

pupil size in eye	pulse rate /beats per minute
	68

The scientist then frightens the student with a sudden loud noise.

Which row shows the results immediately after the loud noise?

	pupil size in eye	pulse rate /beats per minute
A		60
B		80
C		60
D		80

11 The diagram shows a flower.

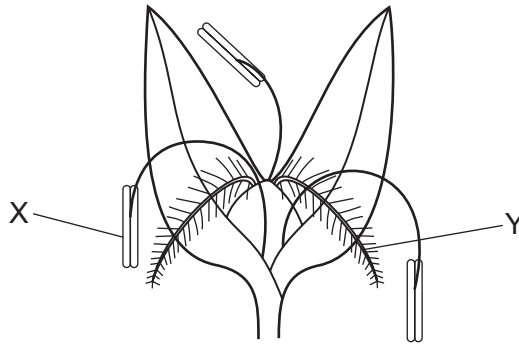

Which row is correct for the flower illustrated?

	X	Y
A	captures insect-carried pollen	produces rough pollen grains
B	captures wind-carried pollen	produces smooth pollen grains
C	produces rough pollen grains	captures insect-carried pollen
D	produces smooth pollen grains	captures wind-carried pollen

12 Materials are exchanged between a mother and her fetus across the placenta.

Which row shows the overall direction of movement of these materials?

	mother to fetus	fetus to mother
A	amino acids	glucose
B	amino acids	urea
C	carbon dioxide	glucose
D	carbon dioxide	urea

13 What is the name given to the position of an organism in a food chain?

- A** ecosystem
- B** energy content
- C** trophic level
- D** tropism

- 14 Which methods of separation depend on the substances in a mixture having different boiling points?
- A** crystallisation and distillation
- B** evaporation and filtration
- C** fractional distillation and chromatography
- D** fractional distillation and distillation

- 15 Which row describes an element and a compound?

	element	compound
A	contains more than one type of atom	contains elements chemically combined
B	contains more than one type of atom	contains elements mixed together
C	contains only one type of atom	contains elements chemically combined
D	contains only one type of atom	contains elements mixed together

- 16 Potassium chloride is a solid.

Hydrogen chloride is a gas.

Which statement explains why potassium chloride has a much higher boiling point than hydrogen chloride?

- A** Covalent bonding is stronger than ionic bonding.
- B** Covalent bonds are stronger than the attractive forces between molecules.
- C** Ionic bonding is stronger than covalent bonding.
- D** Ionic bonds are stronger than the attractive forces between molecules.
- 17 Ammonium phosphate has the formula $(\text{NH}_4)_3\text{PO}_4$.

Which row shows the formulae of ammonium ions and phosphate ions?

	ammonium	phosphate
A	NH_4^+	PO_4^-
B	NH_4^{3+}	PO_4^{3-}
C	NH_4^+	PO_4^{3-}
D	NH_4^{3+}	PO_4^-

18 Which process occurs during electrolysis?

- A Anions gain electrons at the anode.
- B Anions lose electrons at the anode.
- C Cations gain electrons at the anode.
- D Cations lose electrons at the cathode.

19 Which energy level diagram represents an exothermic reaction with the greatest activation energy?

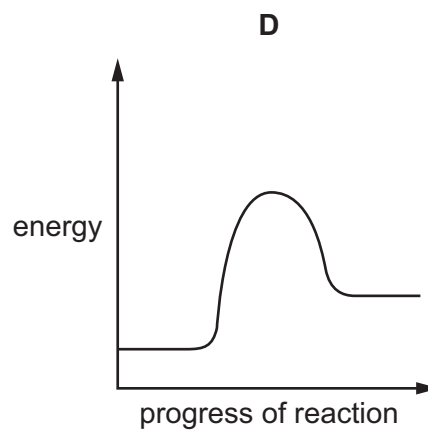
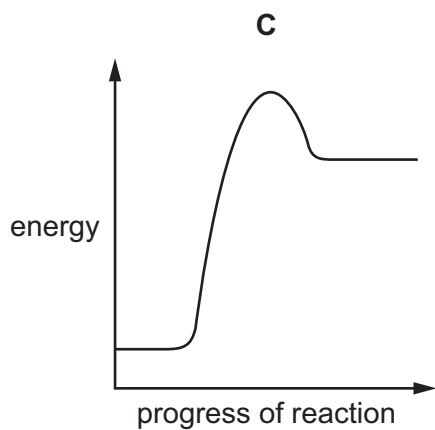
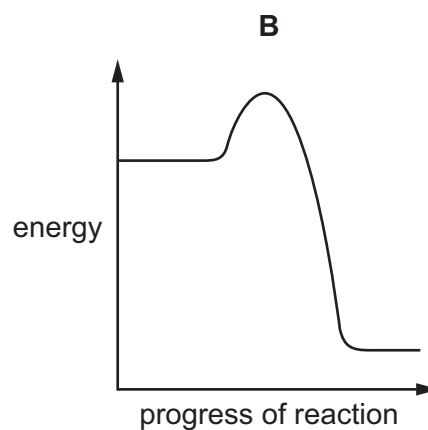
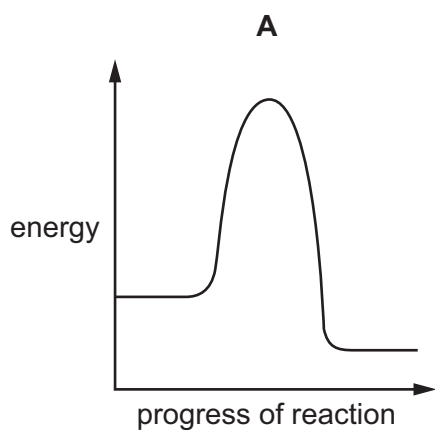

20 Zinc reacts with dilute hydrochloric acid.

Which row explains the effect of increasing the temperature on this reaction?

	frequency of collisions between reacting particles	number of particles possessing the minimum energy for the reaction
A	decreases	increases
B	decreases	stays the same
C	increases	increases
D	increases	stays the same

21 Copper is extracted from its ore by heating with carbon.

What is the role of the carbon in this process?

- A** fuel
- B** electrolyte
- C** oxidising agent
- D** reducing agent

22 A mixture of ammonium carbonate and ammonium chloride is heated with aqueous sodium hydroxide.

Which gas is produced?

- A** ammonia
- B** carbon dioxide
- C** chlorine
- D** hydrogen chloride

- 23 The diagram shows what happens when damp red litmus paper is placed into two different gases, X and Y.

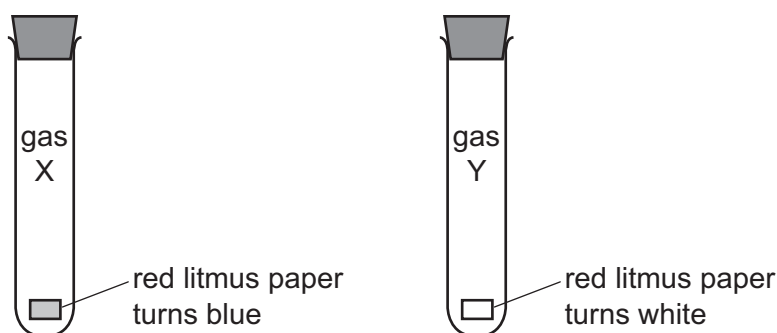

What are gases X and Y?

	X	Y
A	ammonia	carbon dioxide
B	ammonia	chlorine
C	chlorine	ammonia
D	chlorine	carbon dioxide

- 24 Different aqueous solutions of halogens and halides are mixed in four beakers.

Which mixture produces a colourless solution?

- A** $Cl_2(aq)$ and $Cl^-(aq)$
B $Br_2(aq)$ and $Br^-(aq)$
C $Cl_2(aq)$ and $Br^-(aq)$
D $Br_2(aq)$ and $Cl^-(aq)$
- 25 Which change shows the presence of water?
- A** Anhydrous copper(II) sulfate turns white.
B Anhydrous copper(II) sulfate turns pink.
C Cobalt(II) chloride paper turns pink.
D Cobalt(II) chloride paper turns blue.

26 A petrol car engine takes in clean air and lets out exhaust gases.

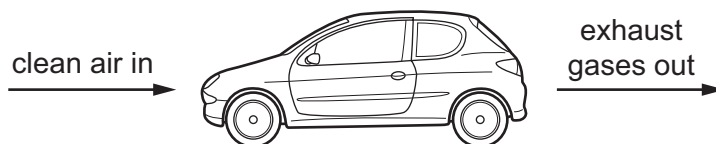

Which gas has a higher concentration in the exhaust gases than in clean air?

- A argon
 - B carbon dioxide
 - C nitrogen
 - D oxygen
- 27 Which statement about hydrocarbons is **not** correct?
- A Alkenes are made by cracking alkanes.
 - B Butene decolourises aqueous bromine.
 - C C_2H_4 is used to make poly(ethene).
 - D The general formula of alkanes is C_nH_{2n} .
- 28 Graph 1 is a distance–time graph. Graph 2 is a speed–time graph.

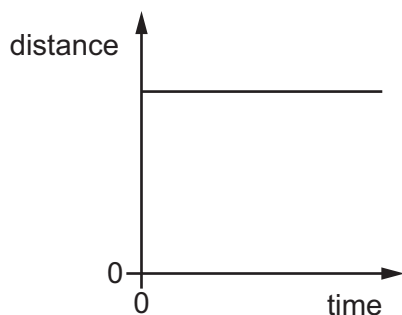

graph 1

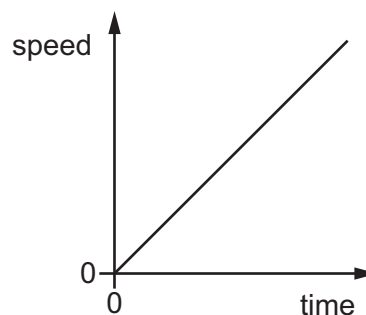

graph 2

Which of these graphs represents a car that is moving at constant speed?

- A graph 1 only
- B graph 2 only
- C both graphs
- D neither graph

29 An object has mass 1.0 kg and weight 10 N on the Earth.

It is moved to another planet where the gravitational field strength is smaller.

What are its mass and weight now?

	mass / kg	weight / N
A	less than 1.0	less than 10
B	less than 1.0	10
C	1.0	less than 10
D	1.0	10

30 A measuring cylinder contains 20 cm^3 of oil. The measuring cylinder is placed on a balance and the reading on the balance is 100 g.

Extra oil is added to the measuring cylinder. The volume increases to 70 cm^3 and the reading on the balance increases to 140 g.

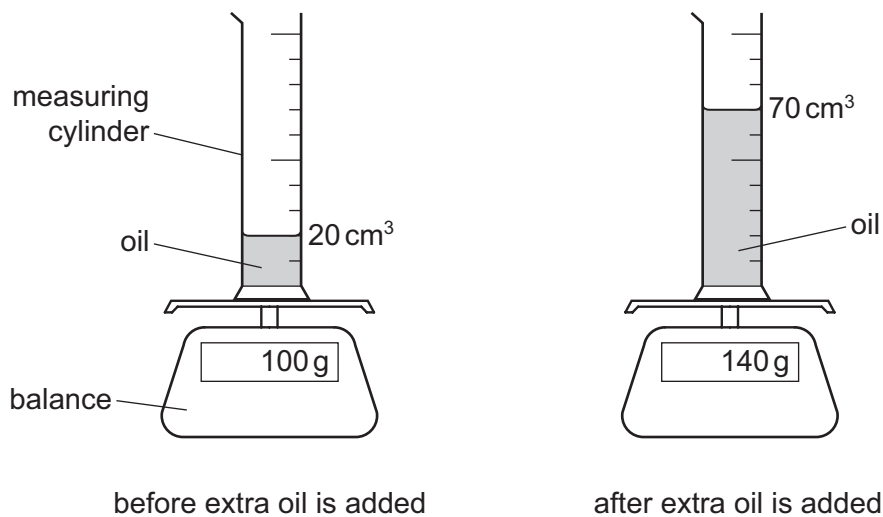

What is the density of the oil?

- A** 0.50 g/cm^3 **B** 0.80 g/cm^3 **C** 1.25 g/cm^3 **D** 2.00 g/cm^3

31 Diagram 1 shows a load hanging on a spring.

Diagram 2 shows the load pulled down.

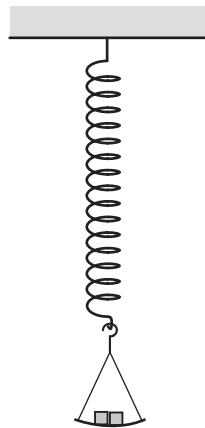

diagram 1

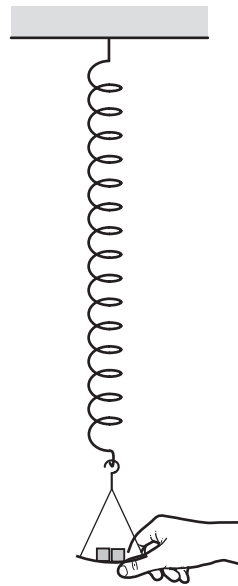

diagram 2

When the load is pulled down, what happens to the gravitational potential energy of the load and the elastic potential (strain) energy of the spring?

	gravitational potential energy of load	elastic potential energy of spring
A	decreases	decreases
B	decreases	increases
C	increases	decreases
D	increases	increases

32 A load of mass 50 kg is lifted vertically by 8.0 m in 20 s.

The gravitational field strength g is 10 N/kg.

How much power is developed in lifting the load?

- A** 125 W **B** 200 W **C** 1600 W **D** 8000 W

- 33 A metal bar is heated at one end.

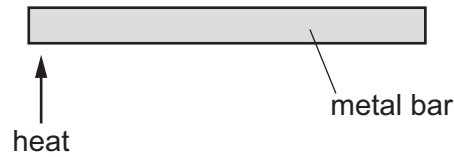

What is the main method by which thermal energy reaches the other end of the bar?

- A Free electrons at the heated end gain kinetic energy and move along the bar.
 - B Free electrons at the heated end move apart and set up a convection current along the bar.
 - C Molecules at the heated end gain kinetic energy and move along the bar.
 - D Molecules at the heated end move apart and set up a convection current along the bar.
- 34 How is thermal energy transferred from the Sun to the Earth through the vacuum of space?
- A by conduction, convection and radiation
 - B by conduction only
 - C by convection only
 - D by radiation only
- 35 Which waves are longitudinal?
- A light waves
 - B microwaves
 - C sound waves
 - D X-rays
- 36 A thin converging lens is used as a magnifying glass.

The focal length of the lens is f .

Where is the object placed?

- A on the opposite side of the lens to the eye and at a distance from the lens between f and $2f$
 - B on the opposite side of the lens to the eye and at a distance from the lens less than f
 - C on the same side of the lens as the eye and at a distance from the lens between f and $2f$
 - D on the same side of the lens as the eye and at a distance from the lens less than f
- 37 There is a current of 5.0 A in a resistor.

How much electric charge passes through the resistor in 30 minutes?

- A 6.0 C
- B 150 C
- C 360 C
- D 9000 C

38 A battery is connected to a resistor.

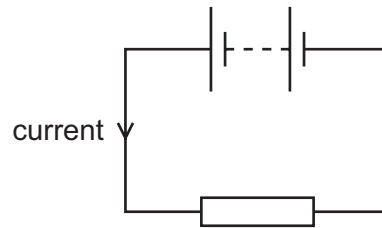

Which changes to the resistance of the resistor, and to the potential difference (p.d.) across the resistor, **must** produce a smaller current?

	resistance	p.d.
A	decrease	decrease
B	decrease	increase
C	increase	decrease
D	increase	increase

39 A piece of wire has electrical resistance.

The wire is stretched so that it becomes longer and thinner.

What happens to its resistance?

- A** It could increase or decrease depending on how much it is stretched.
- B** It does not change because the effect of its smaller diameter cancels the effect of its greater length.
- C** It must decrease.
- D** It must increase.

40 The diagrams show four arrangements of resistors.

Which arrangement has the **smallest** total resistance?

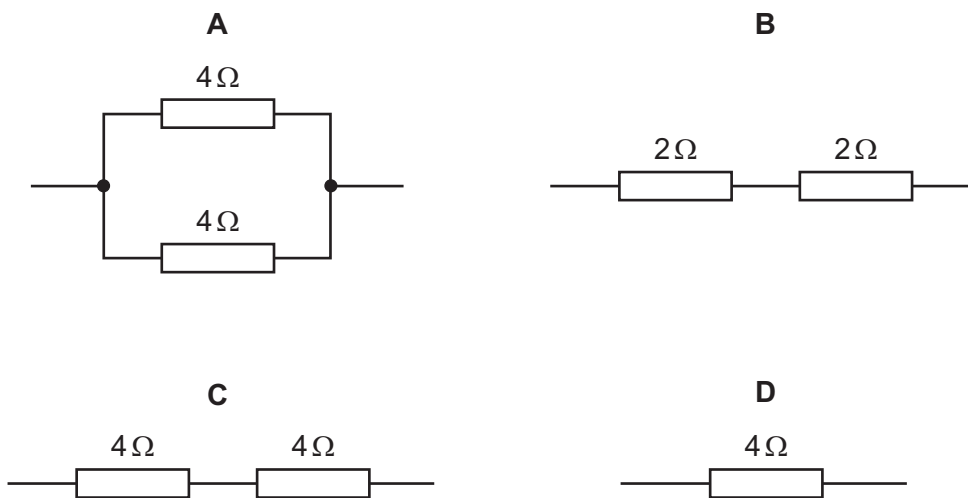

BLANK PAGE

BLANK PAGE

BLANK PAGE

Permission to reproduce items where third-party owned material protected by copyright is included has been sought and cleared where possible. Every reasonable effort has been made by the publisher (UCLES) to trace copyright holders, but if any items requiring clearance have unwittingly been included, the publisher will be pleased to make amends at the earliest possible opportunity.

To avoid the issue of disclosure of answer-related information to candidates, all copyright acknowledgements are reproduced online in the Cambridge Assessment International Education Copyright Acknowledgements Booklet. This is produced for each series of examinations and is freely available to download at www.cambridgeinternational.org after the live examination series.

Cambridge Assessment International Education is part of the Cambridge Assessment Group. Cambridge Assessment is the brand name of the University of Cambridge Local Examinations Syndicate (UCLES), which itself is a department of the University of Cambridge.

