



Cambridge Assessment International Education
Cambridge International General Certificate of Secondary Education

CANDIDATE
NAME

CENTRE
NUMBER

--	--	--	--	--

CANDIDATE
NUMBER

--	--	--	--

* 8 0 5 7 6 3 5 5 1 5 *



CHEMISTRY

0620/42

Paper 4 Theory (Extended)

May/June 2019

1 hour 15 minutes

Candidates answer on the Question Paper.

No Additional Materials are required.

READ THESE INSTRUCTIONS FIRST

Write your centre number, candidate number and name on all the work you hand in.

Write in dark blue or black pen.

You may use an HB pencil for any diagrams or graphs.

Do not use staples, paper clips, glue or correction fluid.

DO **NOT** WRITE IN ANY BARCODES.

Answer **all** questions.

Electronic calculators may be used.

A copy of the Periodic Table is printed on page 16.

You may lose marks if you do not show your working or if you do not use appropriate units.

At the end of the examination, fasten all your work securely together.

The number of marks is given in brackets [] at the end of each question or part question.

This syllabus is regulated for use in England, Wales and Northern Ireland as a Cambridge International Level 1/Level 2 Certificate.

This document consists of **13** printed pages and **3** blank pages.

1 The names of eight substances are given.

aluminium oxide

calcium oxide

ethanol

nitrogen

iron(III) oxide

methane

oxygen

silicon(IV) oxide

Answer the following questions about these substances.

Each substance may be used once, more than once or not at all.

State which substance is:

(a) the main constituent of natural gas

..... [1]

(b) a reactant in respiration

..... [1]

(c) the main constituent of bauxite

..... [1]

(d) a product of photosynthesis

..... [1]

(e) a greenhouse gas

..... [1]

(f) a macromolecular solid.

..... [1]

[Total: 6]

2 (a) $^{22}_{11}\text{Na}$, $^{23}_{11}\text{Na}$ and $^{24}_{11}\text{Na}$ are isotopes of sodium.

(i) Describe how these sodium isotopes are the same and how they are different in terms of the total number of protons, neutrons and electrons in each.

same

.....

different

.....

[3]

(ii) Why do all **three** isotopes have an overall charge of zero?

.....

..... [1]

(iii) Why do all **three** isotopes have the same chemical properties?

.....

..... [2]

(iv) Why do sodium ions have a charge of +1?

.....

..... [1]

(b) Carbon is an element which exists in different forms.

(i) Name **two** forms of the element carbon that have giant covalent structures.

..... and [1]

(ii) Name the oxide of carbon that is a toxic gas.

..... [1]

[Total: 9]

3 This question is about phosphorus and compounds of phosphorus.

(a) Phosphorus has the formula P_4 . Some properties of P_4 are shown.

melting point/ $^{\circ}C$	45
boiling point/ $^{\circ}C$	280
electrical conductivity	non-conductor
solubility in water	insoluble

(i) Name the type of bonding that exists between the atoms in a P_4 molecule.

..... [1]

(ii) Explain, in terms of attractive forces between particles, why P_4 has a low melting point.

.....
 [1]

(iii) Explain why phosphorus is a non-conductor of electricity.

.....
 [1]

(b) Phosphorus, P_4 , reacts with air to produce phosphorus(V) oxide, P_4O_{10} .

(i) Write a chemical equation for this reaction.

..... [2]

(ii) What type of chemical reaction is this?

..... [1]

(c) Phosphorus(V) oxide, P_4O_{10} , is an acidic oxide.

Phosphorus(V) oxide, P_4O_{10} , reacts with aqueous sodium hydroxide to form a salt containing the phosphate ion, PO_4^{3-} . Water is the only other product.

Write a chemical equation for the reaction between phosphorus(V) oxide and aqueous sodium hydroxide.

..... [2]

(d) Phosphine has the formula PH_3 .

Complete the dot-and-cross diagram to show the electron arrangement in a molecule of phosphine. Show outer shell electrons only.

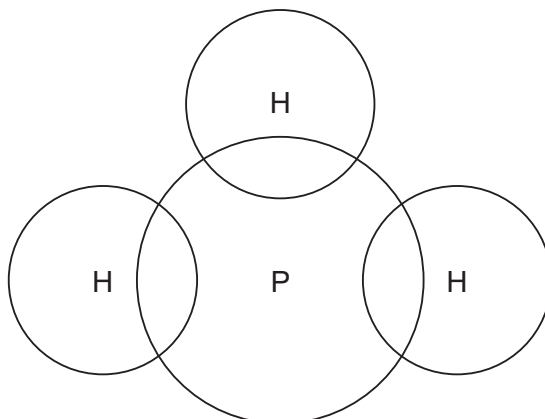

[2]

(e) Phosphine, PH_3 , has a similar chemical structure to ammonia, NH_3 .

Ammonia acts as a base when it reacts with sulfuric acid.

(i) What is meant by the term *base*?

..... [1]

(ii) Write a chemical equation for the reaction between ammonia and sulfuric acid.

..... [2]

[Total: 13]

- 4 Methanol is made industrially by reacting carbon monoxide with hydrogen. The gases react at a temperature of 250 °C and a pressure of 75 atmospheres.

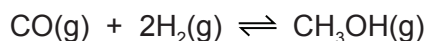

The forward reaction is exothermic.

- (a) Suggest a source of hydrogen for this industrial process.

..... [1]

- (b) Complete the table using only the words *increases*, *decreases* or *no change*.

	effect on the rate of the reverse reaction	effect on the equilibrium yield of CH ₃ OH(g)
adding a catalyst		no change
increasing the temperature	increases	
decreasing the pressure		

[4]

- (c) Methanol is a member of the homologous series of alcohols.

- (i) State **two** general characteristics of a homologous series.

1

2

[2]

- (ii) Draw the structures of **two** different alcohols, each containing **three** carbon atoms. Show all of the atoms and all of the bonds.

Name these **two** alcohols.

name

name

[4]

- (iii) What term is used to describe compounds with the same molecular formula but different structural formulae?

..... [1]

- (d) Alcohols react with carboxylic acids to produce esters.

- (i) The structure of ester **X** is shown.

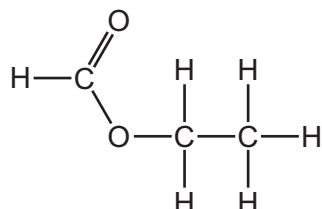

Name ester **X**.

..... [1]

- (ii) Give the name of the carboxylic acid and the alcohol that react together to produce ester **X**.

carboxylic acid

alcohol

[2]

- (iii) Ester **Y** is different from ester **X** but also has the formula $C_3H_6O_2$.

Draw the structure of ester **Y**. Show all of the atoms and all of the bonds.

..... [2]

[Total: 17]

- 5 Copper(II) sulfate crystals, $\text{CuSO}_4 \cdot 5\text{H}_2\text{O}$, are hydrated.

Copper(II) sulfate crystals are made by reacting copper(II) carbonate with dilute sulfuric acid.

The equation for the overall process is shown.



- step 1** Powdered solid copper(II) carbonate is added to 50.0 cm^3 of 0.05 mol/dm^3 sulfuric acid until the copper(II) carbonate is in excess.
- step 2** The excess of copper(II) carbonate is separated from the aqueous copper(II) sulfate.
- step 3** The aqueous copper(II) sulfate is heated until the solution is saturated.
- step 4** The solution is allowed to cool and crystallise.
- step 5** The crystals are removed and dried.
- (a) Calculate the maximum mass of the copper(II) sulfate crystals, $\text{CuSO}_4 \cdot 5\text{H}_2\text{O}$, that can form using the following steps.

- Calculate the number of moles of H_2SO_4 in 50.0 cm^3 of $0.05 \text{ mol/dm}^3 \text{ H}_2\text{SO}_4$.

..... mol

- Determine the number of moles of $\text{CuSO}_4 \cdot 5\text{H}_2\text{O}$ that can form.

..... mol

- The M_r of $\text{CuSO}_4 \cdot 5\text{H}_2\text{O}$ is 250.

Calculate the maximum mass of $\text{CuSO}_4 \cdot 5\text{H}_2\text{O}$ that can form.

..... g
[3]

(b) **Steps 1–5** were done correctly but the mass of crystals obtained was less than the maximum mass.

Explain why.

..... [1]

(c) State **two** observations that would indicate that the copper(II) carbonate is in excess in **step 1**.

1

2

[2]

(d) When the reaction in **step 1** is done using lumps of copper(II) carbonate instead of powder, the rate of reaction decreases. All other conditions are kept the same.

Give a reason for this. Explain your answer in terms of particles.

.....
.....
..... [2]

(e) Name a different substance, other than copper(II) carbonate, that could be added to dilute sulfuric acid to produce copper(II) sulfate in **step 1**.

..... [1]

(f) Name the process used to separate the aqueous copper(II) sulfate from the excess of copper(II) carbonate in **step 2**.

..... [1]

(g) The solution of aqueous copper(II) sulfate was heated until it was saturated in **step 3**.

(i) Suggest what is meant by the term *saturated solution*.

.....
.....
..... [2]

(ii) What evidence would show that the solution was saturated in **step 3**?

..... [1]

(iii) Why should the aqueous copper(II) sulfate **not** be heated to dryness in **step 3**?

..... [1]

[Total: 14]

6 The halogens are the elements in Group VII of the Periodic Table.

(a) Predict the physical state and colour of astatine at room temperature and pressure.

physical state

colour

[2]

(b) When chlorine reacts with aqueous potassium bromide a displacement reaction occurs.

(i) Describe the colour change of the solution.

from to

[2]

(ii) Write a chemical equation for this reaction.

..... [2]

(c) Reactions occur when some aqueous solutions of halogens are added to aqueous solutions of halides.

Use the key to complete the table to show the results of adding halogens to halides.

key

✓ = reaction

x = no reaction

		halides		
		KCl(aq)	KBr(aq)	KI(aq)
halogens	Cl ₂ (aq)		✓	
	Br ₂ (aq)			
	I ₂ (aq)			

[2]

[Total: 8]

- 7 (a) Displacement reactions occur between metals and metal ions.

Displacement reactions can be used to determine the order of reactivity of metals such as lead (Pb), nickel (Ni), and silver (Ag).

The ionic equation for a displacement reaction is shown.

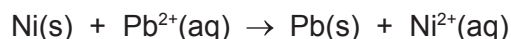

The ionic half-equations for this reaction are shown.

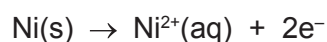

The ionic half-equations show that electrons are donated by nickel atoms and accepted by lead ions.

- (i) Identify the reducing agent in the displacement reaction. Give a reason for your answer.

reducing agent.....

reason.....

[2]

- (ii) What is the general term given to the type of reaction in which electrons are transferred from one species to another?

..... [1]

- (b) The ionic equation for another displacement reaction is shown.

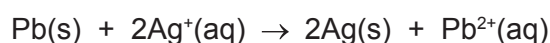

Write the **two** ionic half-equations for this reaction.

1

2

[2]

- (c) Use the information in (a) and (b) to put the **three** metals lead, nickel and silver in order of reactivity.

	most reactive
	↑
	least reactive

[1]

(d) Nickel is a transition element. Nickel is stronger than sodium.

Describe **two** other differences in the physical properties of nickel and sodium.

1

2

[2]

(e) Predict **one** difference in the appearance of aqueous solutions of nickel compounds compared to aqueous solutions of sodium compounds.

.....

..... [1]

(f) Copper is refined (purified) by electrolysis. Nickel can be refined using a similar method.

(i) The diagram shows the refining of nickel by electrolysis.

Complete the labels in the boxes.

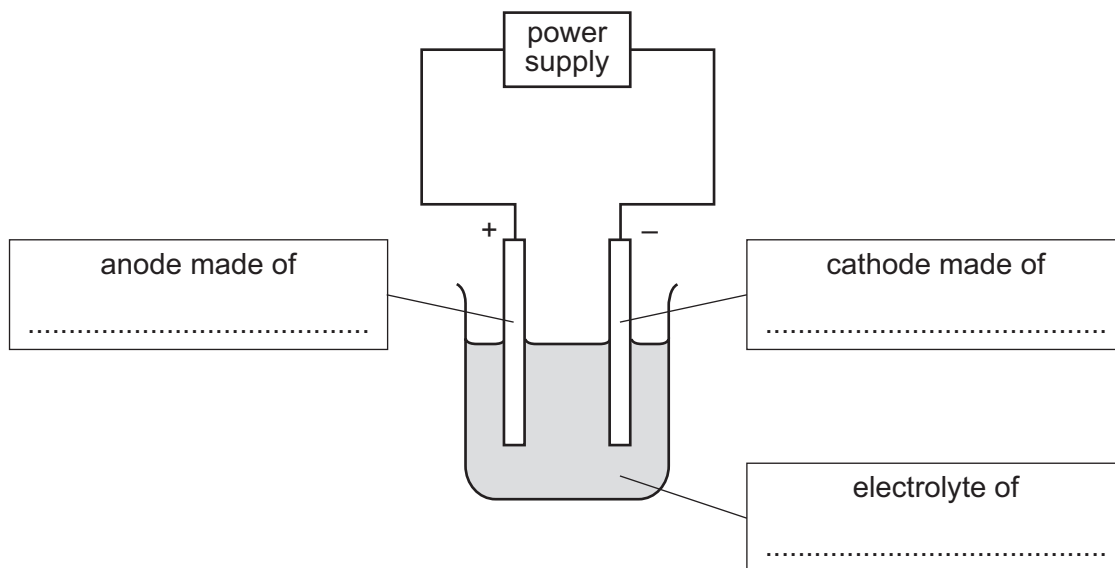

[3]

(ii) Indicate, by writing **N** on the diagram, where nickel is produced.

[1]

[Total: 13]

BLANK PAGE

BLANK PAGE

BLANK PAGE

Permission to reproduce items where third-party owned material protected by copyright is included has been sought and cleared where possible. Every reasonable effort has been made by the publisher (UCLES) to trace copyright holders, but if any items requiring clearance have unwittingly been included, the publisher will be pleased to make amends at the earliest possible opportunity.

To avoid the issue of disclosure of answer-related information to candidates, all copyright acknowledgements are reproduced online in the Cambridge Assessment International Education Copyright Acknowledgements Booklet. This is produced for each series of examinations and is freely available to download at www.cambridgeinternational.org after the live examination series.

Cambridge Assessment International Education is part of the Cambridge Assessment Group. Cambridge Assessment is the brand name of the University of Cambridge Local Examinations Syndicate (UCLES), which itself is a department of the University of Cambridge.

The Periodic Table of Elements

		Group															
I	II	III	IV	V	VI	VII	VIII										
1	2	3	4	5	6	7	8	9	10	11	12	13	14	15	16	17	18
Li lithium 7	Be beryllium 9	B boron 11	C carbon 12	N nitrogen 14	O oxygen 16	F fluorine 19	Ne neon 20										
11	12	13	14	15	16	17	18										
Na sodium 23	Mg magnesium 24	Al aluminium 27	Si silicon 28	P phosphorus 31	S sulfur 32	Cl chlorine 35.5	Ar argon 40										
19	20	21	22	23	24	25	26	27	28	29	30	31	32	33	34	35	36
K potassium 39	Ca calcium 40	Sc scandium 45	Ti titanium 48	V vanadium 51	Cr chromium 52	Mn manganese 55	Fe iron 56	Co cobalt 59	Ni nickel 59	Cu copper 64	Zn zinc 65	Ga gallium 70	Ge germanium 73	As arsenic 75	Se selenium 79	Br bromine 80	Kr krypton 84
37	38	39	40	41	42	43	44	45	46	47	48	49	50	51	52	53	54
Rb rubidium 85	Sr strontium 88	Y yttrium 89	Zr zirconium 91	Nb niobium 93	Mo molybdenum 96	Tc technetium —	Ru ruthenium 101	Rh rhodium 103	Pd palladium 106	Ag silver 108	Cd cadmium 112	In indium 115	Sn tin 119	Sb antimony 122	Te tellurium 128	I iodine 127	Xe xenon 131
55	56	57-71	72	73	74	75	76	77	78	79	80	81	82	83	84	85	86
Cs caesium 133	Ba barium 137	lanthanoids	Hf hafnium 178	Ta tantalum 181	W tungsten 184	Re rhenium 186	Os osmium 190	Ir iridium 192	Pt platinum 195	Au gold 197	Hg mercury 201	Tl thallium 204	Pb lead 207	Bi bismuth 209	Po polonium —	At astatine —	Rn radon —
87	88	89-103	104	105	106	107	108	109	110	111	112	113	114	115	116	117	118
Fr francium —	Ra radium —	actinoids	Rf rutherfordium —	Db dubnium —	Sg seaborgium —	Bh bohrium —	Hs hassium —	Mt meitnerium —	Ds darmstadtium —	Rg roentgenium —	Cn copernicium —	Nh nihonium —	Fl flerovium —	Lv livermorium —	Uu ununoctium —	Uub unubium —	Uuq unquadium —

Key

atomic number
atomic symbol
name
relative atomic mass

1
H
hydrogen
1

57	58	59	60	61	62	63	64	65	66	67	68	69	70	71
La lanthanum 139	Ce cerium 140	Pr praseodymium 141	Nd neodymium 144	Pm promethium —	Sm samarium 150	Eu europium 152	Gd gadolinium 157	Tb terbium 159	Dy dysprosium 163	Ho holmium 165	Er erbium 167	Tm thulium 169	Yb ytterbium 173	Lu lutetium 175
89	90	91	92	93	94	95	96	97	98	99	100	101	102	103
Ac actinium —	Th thorium 232	Pa protactinium 231	U uranium 238	Np neptunium —	Pu plutonium —	Am americium —	Cm curium —	Bk berkelium —	Cf californium —	Es einsteinium —	Fm fermium —	Md mendelevium —	No nobelium —	Lr lawrencium —

lanthanoids

actinoids

The volume of one mole of any gas is 24 dm³ at room temperature and pressure (r.t.p.).