



# Cambridge IGCSE™

---

## BIOLOGY

0610/21

Paper 2 Multiple Choice (Extended)

May/June 2020

45 minutes

You must answer on the multiple choice answer sheet.

You will need: Multiple choice answer sheet  
Soft clean eraser  
Soft pencil (type B or HB is recommended)

---

## INSTRUCTIONS

- There are **forty** questions on this paper. Answer **all** questions.
- For each question there are four possible answers **A, B, C** and **D**. Choose the **one** you consider correct and record your choice in soft pencil on the multiple choice answer sheet.
- Follow the instructions on the multiple choice answer sheet.
- Write in soft pencil.
- Write your name, centre number and candidate number on the multiple choice answer sheet in the spaces provided unless this has been done for you.
- Do **not** use correction fluid.
- Do **not** write on any bar codes.
- You may use a calculator.

## INFORMATION

- The total mark for this paper is 40.
- Each correct answer will score one mark. A mark will not be deducted for a wrong answer.
- Any rough working should be done on this question paper.

---

This document has **16** pages. Blank pages are indicated.



- 1 The diagram shows what happened in an experiment with plant seedlings.

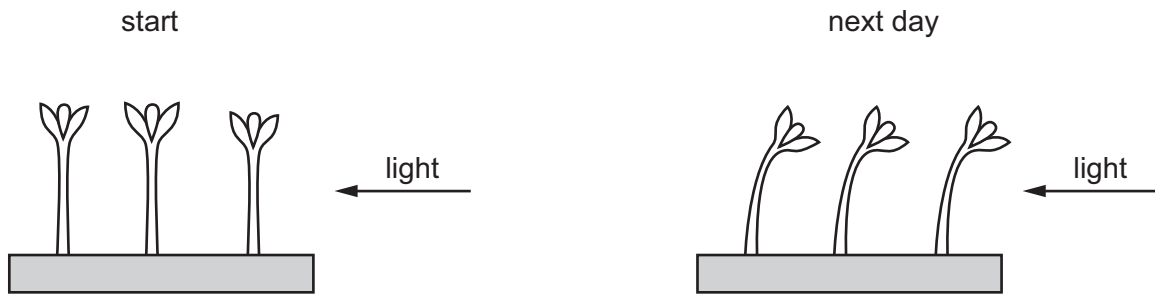

Which characteristic of living things made the seedlings grow towards the light?

- A excretion
  - B nutrition
  - C respiration
  - D sensitivity
- 2 A rat has the scientific name *Rattus rattus*.

What do the two parts of this name refer to?

- A genus and species
  - B kingdom and genus
  - C kingdom and species
  - D variety and genus
- 3 The diagram shows two guard cells.

Which label shows the cell wall?

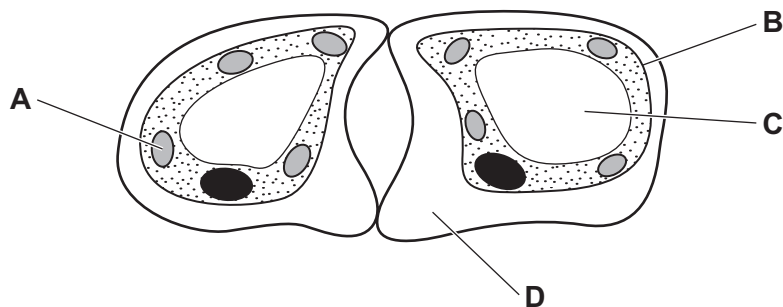

4 The diagrams show different levels of organisation in a plant. (Not drawn to scale.)



1

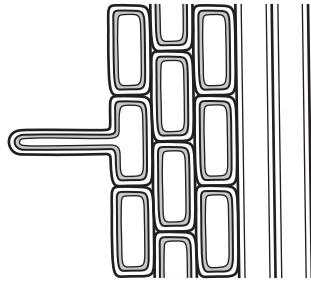

2

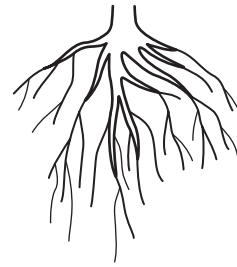

3

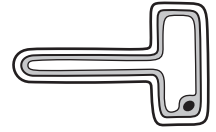

4

Which sequence shows the levels of organisation in order from smallest to largest?

- A 4 → 2 → 3 → 1
- B 4 → 3 → 1 → 2
- C 3 → 4 → 2 → 1
- D 3 → 2 → 1 → 4

5 Which diagram shows the appearance of a plant cell several minutes after it has been placed in a concentrated solution of sugar?

A

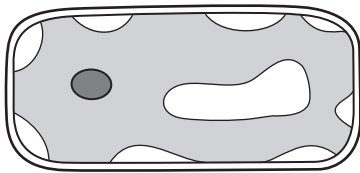

B

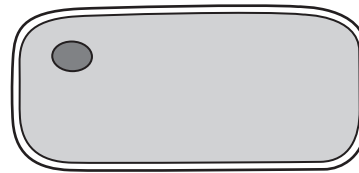

C

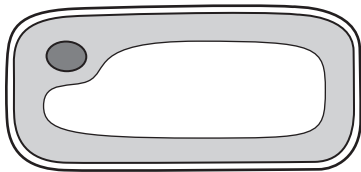

D

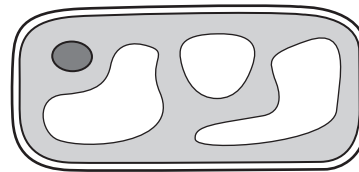

- 6 Plant cells are placed in a solution with a higher water potential than the plant cell contents.

What will happen?

	direction of water movement	volume of vacuole
<b>A</b>	enters cells	decreases
<b>B</b>	enters cells	increases
<b>C</b>	leaves cells	decreases
<b>D</b>	leaves cells	increases

- 7 The diagram shows a section of DNA, with four bases identified on one strand.

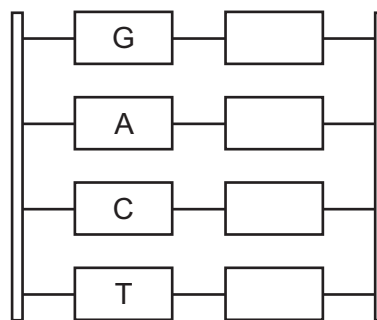

Which sequence of bases would be on the other strand, starting from the top?

- A** AGTC      **B** CTGA      **C** GACT      **D** TCAG
- 8 Which food-testing solution shows a positive result when it turns from blue to purple?
- A** Benedict's solution  
**B** biuret solution  
**C** ethanol  
**D** iodine solution
- 9 What is the definition of an enzyme?
- A** a carbohydrate that acts as a catalyst  
**B** a DNA molecule that acts as a catalyst  
**C** a fat that acts as a catalyst  
**D** a protein that acts as a catalyst

10 An experiment is set up to investigate gas exchange in aquatic plants.

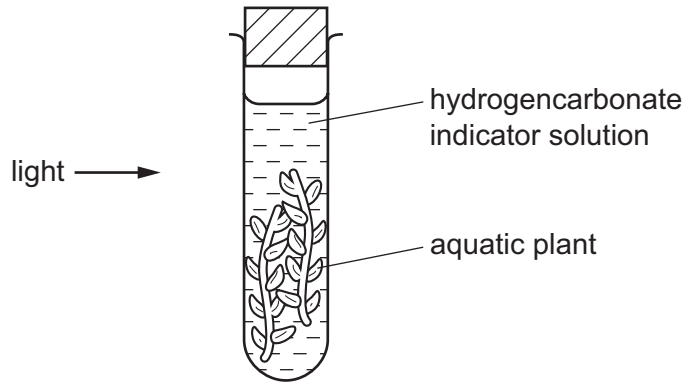

The hydrogencarbonate indicator solution is orange at the start.

Which colour is it after three hours?

- A blue-black
- B orange
- C purple
- D yellow

11 The diagram shows how the rate of photosynthesis varies with light intensity.

The four curves show different conditions of temperature and carbon dioxide concentration.

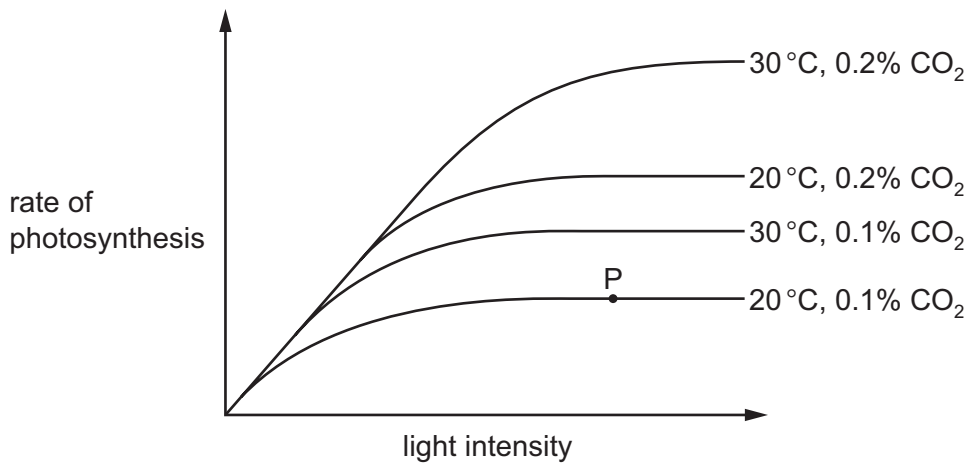

What limits the rate of photosynthesis at point P?

	light intensity	carbon dioxide concentration	temperature	
<b>A</b>	✓	✓	x	key ✓ = yes x = no
<b>B</b>	✓	x	x	
<b>C</b>	x	✓	✓	
<b>D</b>	x	x	✓	

12 Four test-tubes are set up as shown.

Which test-tube contains the least carbon dioxide after one hour?

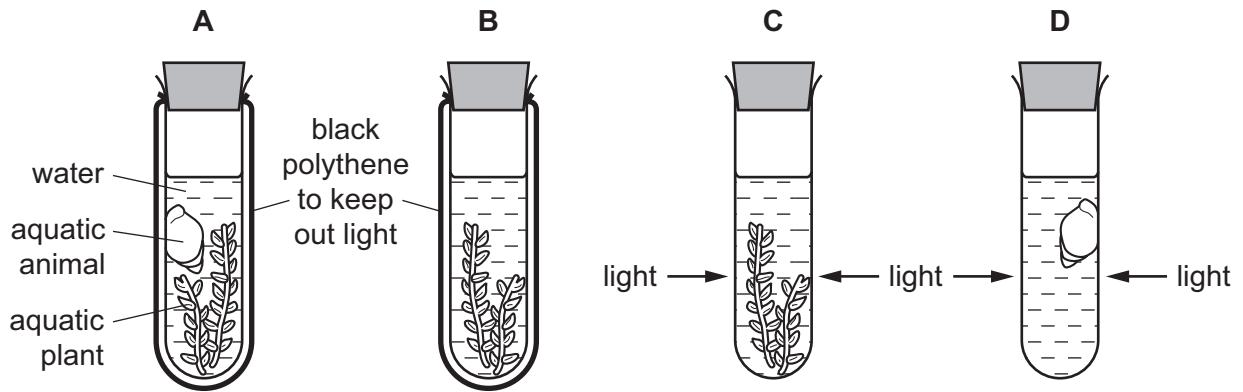

13 The activity of amylase is measured in four parts of the alimentary canal.

Which two parts have the most amylase activity?

- A colon and duodenum
- B colon and stomach
- C mouth and duodenum
- D stomach and mouth

14 Biological washing powder can be used to remove stains on clothing.

Which enzymes will remove stains caused by starch, fat and protein?

	amylase	lipase	trypsin
<b>A</b>	✓	x	x
<b>B</b>	✓	✓	✓
<b>C</b>	x	x	✓
<b>D</b>	x	✓	✓

key

✓ = removes stain

x = does not remove stain

- 15 The graph shows the rate of uptake of magnesium ions by two similar plants, X and Y.

The roots of each plant were placed in a range of solutions. Each solution contained a different concentration of magnesium ions. All other conditions were kept constant.

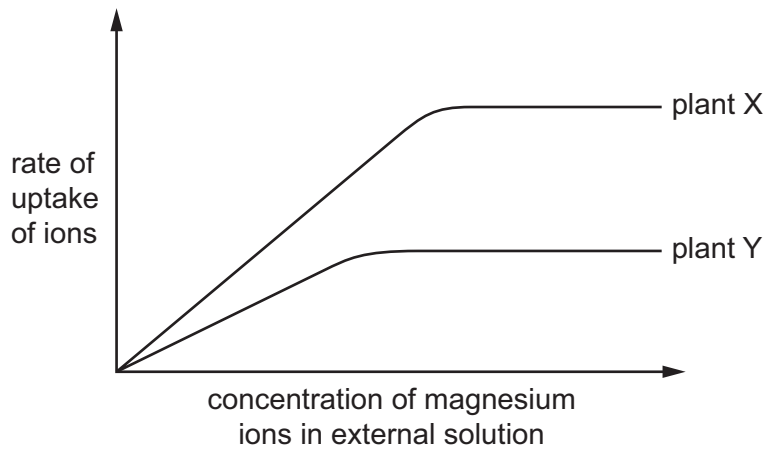

What is a possible explanation for the difference in the results for the two plants?

- A Plant Y has fewer protein molecules for magnesium ion transport in its cell membranes.
  - B Plant Y has a higher rate of respiration.
  - C Plant Y has more root hair cells.
  - D The root hair cells in plant Y have a lower water potential.
- 16 What will increase the rate of transpiration in a plant?
- A an increase in the humidity of the atmosphere surrounding the leaf
  - B an increase in the surface area of the cell surfaces inside the leaf
  - C a decrease in the number of stomata present on the surface of the leaf
  - D a decrease in the temperature of the atmosphere surrounding the leaf
- 17 Which pathway is taken by blood in a fish?
- A gills → heart → body → gills
  - B body → gills → heart → body
  - C heart → gills → body → heart
  - D heart → body → gills → body

18 The diagram shows a section through the heart and its blood vessels.

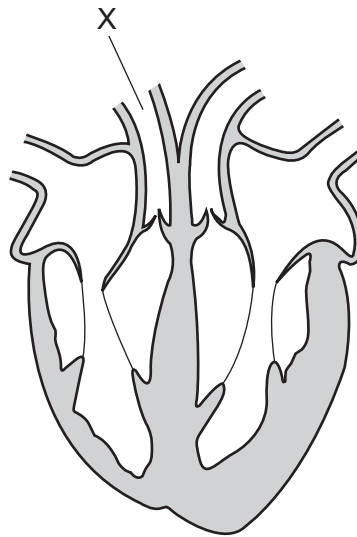

Which row gives the vessel name and the direction of blood flow in vessel X?

	vessel name	direction of blood flow
<b>A</b>	aorta	towards the lungs
<b>B</b>	pulmonary artery	towards the lungs
<b>C</b>	pulmonary artery	away from the lungs
<b>D</b>	vena cava	away from the lungs

19 When a pathogen enters the blood, the immune system uses different mechanisms to destroy the pathogen.

The diagram shows one of these mechanisms.

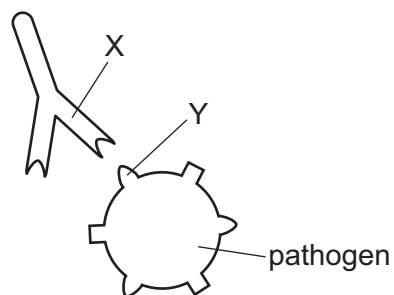

Which row describes the structures involved?

	structure X	X is made by	structure Y
<b>A</b>	antigen	lymphocytes	antibody
<b>B</b>	antigen	phagocytes	antibody
<b>C</b>	antibody	lymphocytes	antigen
<b>D</b>	antibody	phagocytes	antigen



20 What is the approximate percentage of oxygen contained in the air breathed out of the lungs?

- A 0%                      B 4%                      C 16%                      D 20%

21 The diagram shows an experiment to investigate the respiration of yeast. Oil prevents oxygen entering the glucose and yeast suspension.

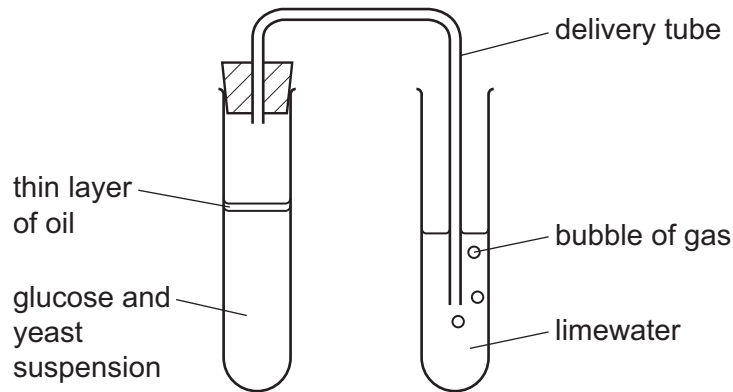

If **no** oxygen is present in the glucose and yeast suspension, what will occur?

- A Ethanol will be produced and the limewater will stay clear.  
 B Ethanol will be produced and the limewater will go cloudy.  
 C Lactic acid will be produced and the limewater will stay clear.  
 D Lactic acid will be produced and the limewater will go cloudy.

22 Which row correctly completes the balanced equation for aerobic respiration?

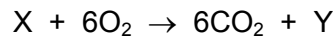

	X	Y
A	$6C_6H_{12}O_6$	$H_2O$
B	$C_6H_{12}O_6$	$6H_2O$
C	$6H_2O$	$C_6H_{12}O_6$
D	$C_6H_{10}O_6$	$6H_2O$

23 In healthy people, which substance is completely reabsorbed into the blood from the kidney tubules?

- A glucose  
 B salts  
 C urea  
 D water

24 The diagram shows a synapse.

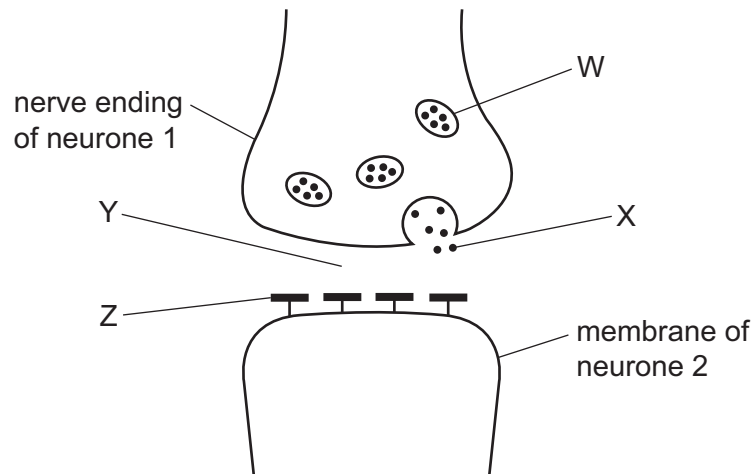

What are the labelled parts?

	W	X	Y	Z
<b>A</b>	synaptic cleft	neurotransmitter	vesicle	receptor
<b>B</b>	synaptic cleft	receptor	vesicle	neurotransmitter
<b>C</b>	vesicle	neurotransmitter	synaptic cleft	receptor
<b>D</b>	vesicle	receptor	synaptic cleft	neurotransmitter

25 Which row shows the actions needed for the eye to focus on a distant object?

	ciliary muscles	suspensory ligaments	lens becomes
<b>A</b>	contract	slacken	thicker
<b>B</b>	relax	slacken	thicker
<b>C</b>	contract	tighten	thinner
<b>D</b>	relax	tighten	thinner

26 The liver and the pancreas work together to control the concentration of glucose in the blood.

Which statement is correct?

- A** The liver converts the small molecule glucose to the large molecule glucagon.
- B** The liver releases the hormone insulin when blood glucose levels are too high.
- C** The pancreas does not respond to an increase in blood glucose levels.
- D** The pancreas responds to a fall in blood glucose by increasing the release of the hormone glucagon.

27 The statements are about the use of antibiotics.

- 1 using an antibiotic to prevent infection
- 2 using an antibiotic known to kill the bacteria causing an infection
- 3 using an antibiotic only when essential
- 4 using an antibiotic to treat a viral infection

Which practices will increase the chance of the development of antibiotic resistance in bacteria?

- A** 1, 2, 3 and 4    **B** 1 and 4 only    **C** 2 and 3 only    **D** 2 and 4 only

28 Which description of cross-pollination is correct?

- A** the transfer of pollen grains from the anther of one plant to the stigma on a different plant  
**B** the transfer of pollen grains from the anther to the stigma on the same plant  
**C** the transfer of pollen grains from the stigma of one plant to the anther on a different plant  
**D** the transfer of pollen grains from the stigma to the anther on the same plant

29 The diagram shows a sperm cell.

Which part contains enzymes that digest the jelly coat of an egg cell?

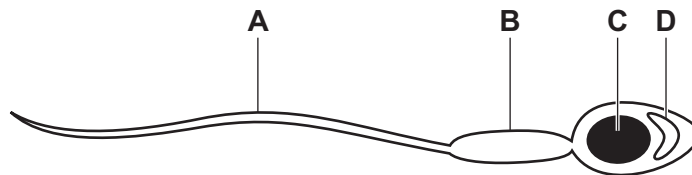

30 Which cell contains a haploid nucleus?

- A** neurone  
**B** sperm cell  
**C** skin cell  
**D** red blood cell

31 The diagram shows the chromosomes of four daughter cells produced by meiosis.

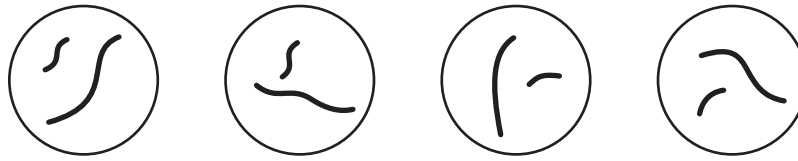

Which parent cell produced these cells?



32 When damaged tissues are repaired cells undergo division by

- A meiosis to produce genetically identical cells.
- B meiosis to produce genetically different cells.
- C mitosis to produce genetically identical cells.
- D mitosis to produce genetically different cells.

33 The graph shows the masses of two different types of tomato.

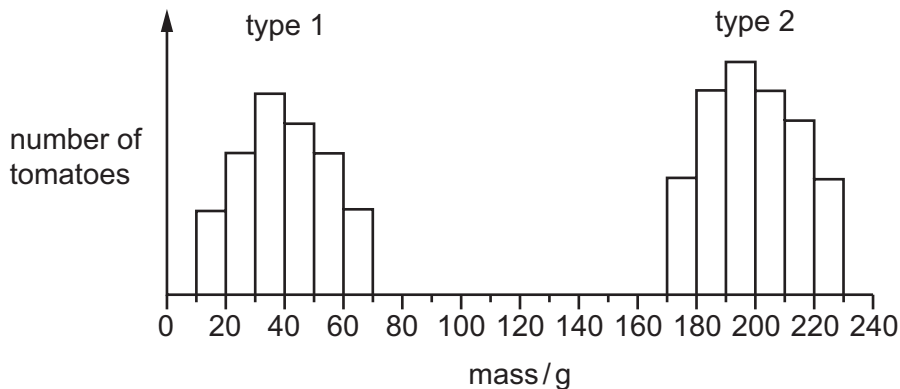

What can be concluded from the graph?

- A Genes do not affect the mass of tomatoes.
- B Type 1 tomatoes show continuous variation.
- C Type 2 tomatoes are sometimes smaller than type 1 tomatoes.
- D Type 2 tomatoes show discontinuous variation.

- 34 Which adaptation may be present in a xerophyte?
- A leaves with small surface area and large numbers of stomata
  - B little or no xylem tissue and leaves with large surface area
  - C stomatal hairs and rolled leaves
  - D thin or no cuticle and deep roots

- 35 The diagram shows a food chain in a rock pool.

seaweed → whelks → crabs → seagulls

What will happen if the number of secondary consumers increases?

There will be

- A fewer crabs.
  - B fewer seagulls.
  - C fewer whelks.
  - D less seaweed.
- 36 What is defined as 'all of the populations of different species in an ecosystem'?
- A community
  - B environment
  - C habitat
  - D trophic level
- 37 What is the role of anaerobic respiration in bread-making?
- A to produce alcohol to flavour the bread
  - B to produce gas to make the bread rise
  - C to release enough energy to bake the bread
  - D to release enough lactic acid to kill the yeast
- 38 A crop plant has been genetically modified to make it resistant to herbicides.
- Which is a possible disadvantage of introducing this new crop plant?
- A Loss of weeds reduces competition.
  - B Some weeds might become resistant to the herbicide.
  - C The crop plant is unharmed and produces a higher yield.
  - D The new gene will appear in new generations of the crop.

**39** Which process in the nitrogen cycle is involved in the breakdown of amino acids in living organisms?

- A** deamination
- B** decomposition
- C** denitrification
- D** digestion

**40** When a river is polluted by fertiliser, the following processes may occur.

- 1 increased aerobic respiration of decomposers
- 2 increased growth of producers
- 3 decreased oxygen concentration in the water

What is the correct sequence for these processes?

- A** 1 → 2 → 3    **B** 1 → 3 → 2    **C** 2 → 1 → 3    **D** 2 → 3 → 1

**BLANK PAGE**

**BLANK PAGE**

---

Permission to reproduce items where third-party owned material protected by copyright is included has been sought and cleared where possible. Every reasonable effort has been made by the publisher (UCLES) to trace copyright holders, but if any items requiring clearance have unwittingly been included, the publisher will be pleased to make amends at the earliest possible opportunity.

To avoid the issue of disclosure of answer-related information to candidates, all copyright acknowledgements are reproduced online in the Cambridge Assessment International Education Copyright Acknowledgements Booklet. This is produced for each series of examinations and is freely available to download at [www.cambridgeinternational.org](http://www.cambridgeinternational.org) after the live examination series.

Cambridge Assessment International Education is part of the Cambridge Assessment Group. Cambridge Assessment is the brand name of the University of Cambridge Local Examinations Syndicate (UCLES), which itself is a department of the University of Cambridge.