

Cambridge  
**IGCSE**

**Cambridge International Examinations**  
Cambridge International General Certificate of Secondary Education

CANDIDATE  
NAME

CENTRE  
NUMBER

--	--	--	--	--	--

CANDIDATE  
NUMBER

--	--	--	--	--

**MATHEMATICS**

**0580/43**

Paper 4 (Extended)

**May/June 2015**

**2 hours 30 minutes**

Candidates answer on the Question Paper.

Additional Materials:      Electronic calculator  
   Tracing paper (optional).

Geometrical instruments

**READ THESE INSTRUCTIONS FIRST**

Write your Centre number, candidate number and name on all the work you hand in.

Write in dark blue or black pen.

You may use an HB pencil for any diagrams or graphs.

Do not use staples, paper clips, glue or correction fluid.

**DO NOT WRITE IN ANY BARCODES.**

Answer **all** questions.

If working is needed for any question it must be shown below that question.

Electronic calculators should be used.

If the degree of accuracy is not specified in the question, and if the answer is not exact, give the answer to three significant figures. Give answers in degrees to one decimal place.

For  $\pi$ , use either your calculator value or 3.142.

At the end of the examination, fasten all your work securely together.

The number of marks is given in brackets [ ] at the end of each question or part question.

The total of the marks for this paper is 130.

The syllabus is approved for use in England, Wales and Northern Ireland as a Cambridge International Level 1/Level 2 Certificate.

This document consists of **16** printed pages.



1

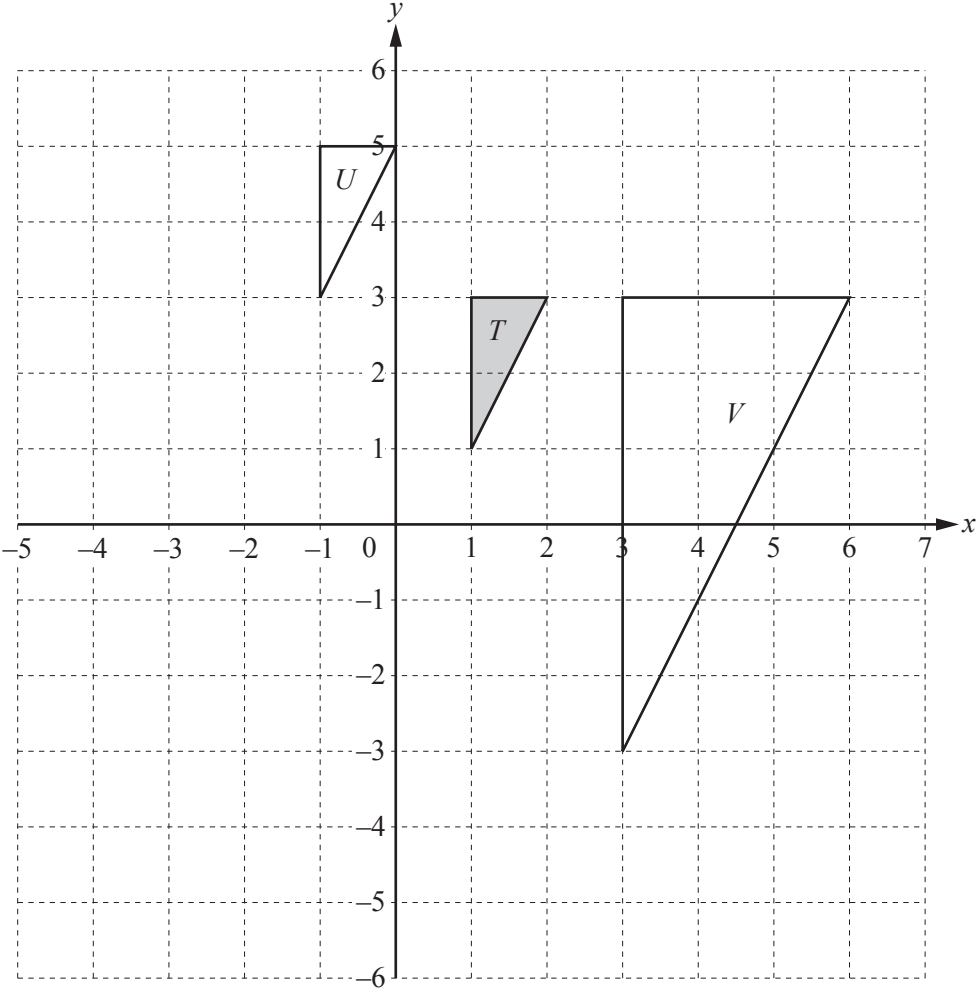

- (a) On the grid, draw the image of
  - (i) triangle *T* after a reflection in the line  $x = -1$ , [2]
  - (ii) triangle *T* after a rotation through  $180^\circ$  about  $(0, 0)$ . [2]
- (b) Describe fully the **single** transformation that maps
  - (i) triangle *T* onto triangle *U*,  
 Answer(b)(i) ..... [2]
  - (ii) triangle *T* onto triangle *V*.  
 Answer(b)(ii) ..... [3]

- 2 (a) (i) Eduardo invests \$640 at a rate of 2% per year compound interest.

Show that, at the end of 6 years, Eduardo has \$721, correct to the nearest dollar.

*Answer(a)(i)*

[2]

- (ii) Manuela also invests \$640.  
At the end of 4 years, Manuela has \$721.

Find the yearly compound interest rate.

*Answer(a)(ii)* ..... % [4]

- (b) Carlos buys a motor scooter for \$1200.  
Each year the value of the scooter decreases by 10% of its value at the beginning of that year.

Find the value of the scooter after 3 years.

*Answer(b)* \$ ..... [2]

3  $f(x) = \frac{8}{x^2} + \frac{x}{2}, \quad x \neq 0.$

(a) Complete the table of values for  $f(x)$ .

$x$	-5	-4	-3	-2	-1.5	1.5	2	2.5	3	3.5	4	5
$f(x)$	-2.2	-1.5	-0.6		2.8	4.3		2.5	2.4	2.4		2.8

[3]

(b) On the grid, draw the graph of  $y = f(x)$  for  $-5 \leq x \leq -1.5$  and  $1.5 \leq x \leq 5$ .

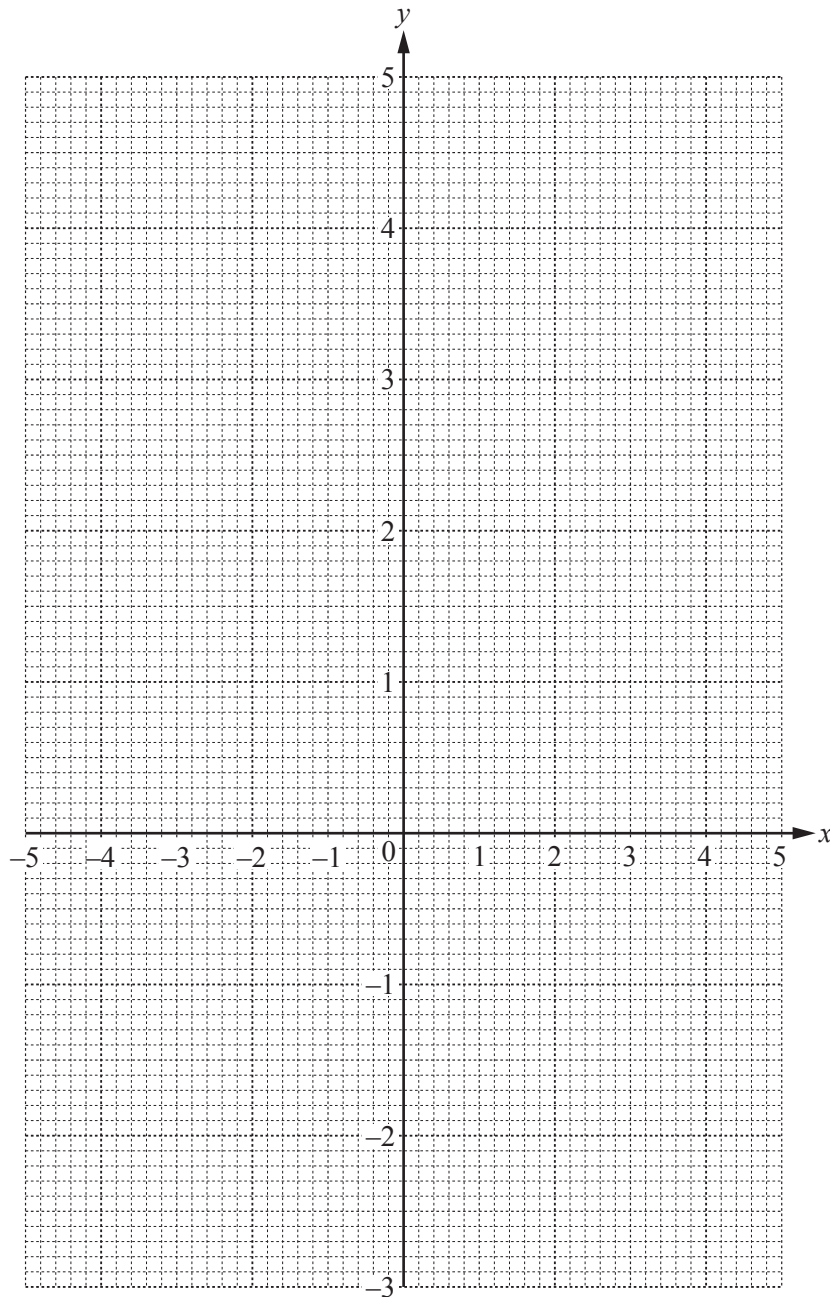

[5]

(c) Solve  $f(x) = 0$ .

*Answer(c)*  $x = \dots\dots\dots$  [1]

(d) By drawing a suitable line on the grid, solve the equation  $f(x) = 1 - x$ .

*Answer(d)*  $x = \dots\dots\dots$  [3]

(e) By drawing a tangent at the point  $(-3, -0.6)$ , estimate the gradient of the graph of  $y = f(x)$  when  $x = -3$ .

*Answer(e)*  $\dots\dots\dots$  [3]

---

4 The table shows the times,  $t$  minutes, taken by 200 students to complete an IGCSE paper.

Time ( $t$ minutes)	$40 < t \leq 60$	$60 < t \leq 70$	$70 < t \leq 75$	$75 < t \leq 90$
Frequency	10	50	80	60

(a) By using mid-interval values, calculate an estimate of the mean time.

Answer(a) ..... min [3]

(b) On the grid, draw a histogram to show the information in the table.

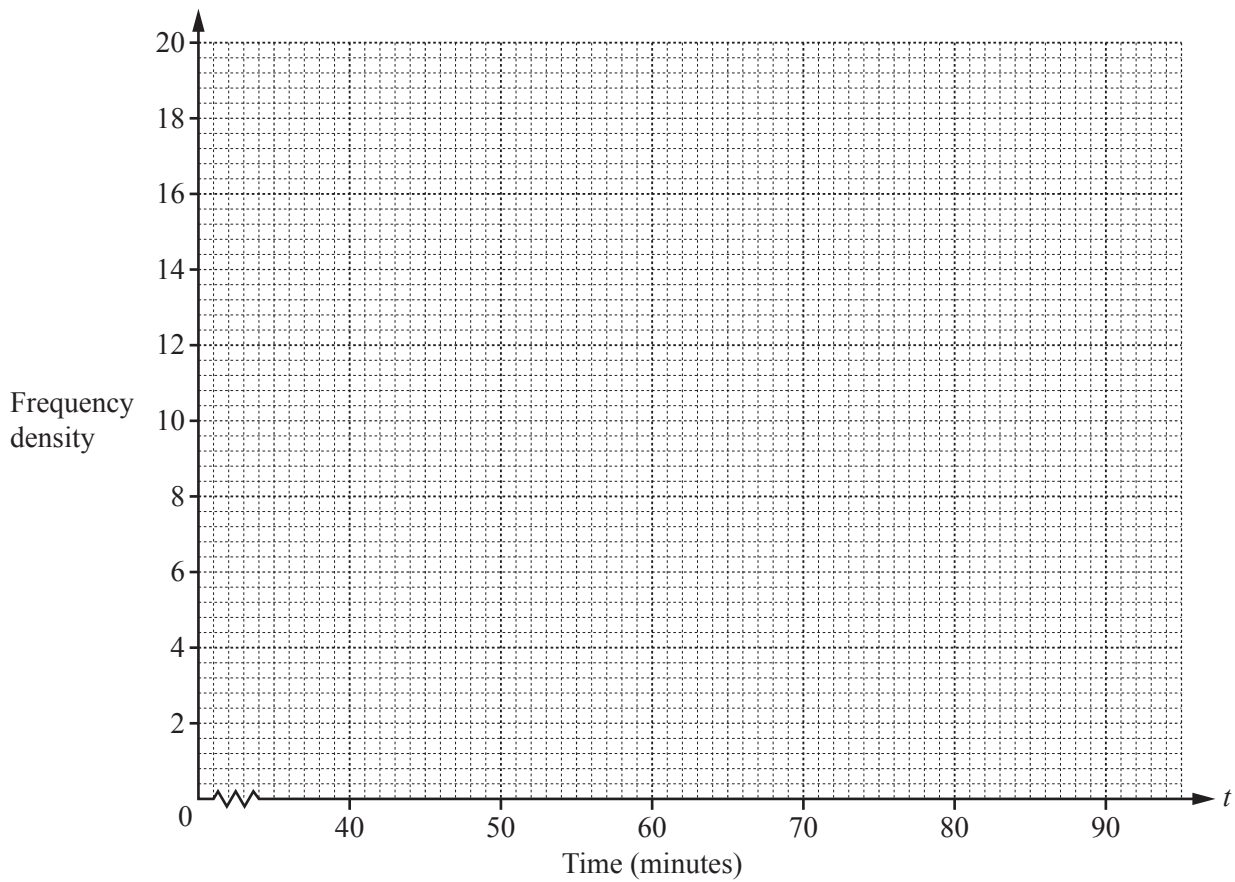

[4]

5



(a) One of these 7 cards is chosen at random.

Write down the probability that the card

(i) shows the letter *A*, *Answer(a)(i)* ..... [1]

(ii) shows the letter *A* or *B*, *Answer(a)(ii)* ..... [1]

(iii) does not show the letter *B*. *Answer(a)(iii)* ..... [1]

(b) Two of the cards are chosen at random, without replacement.

Find the probability that

(i) both show the letter *A*, *Answer(b)(i)* ..... [2]

(ii) the two letters are different. *Answer(b)(ii)* ..... [3]

(c) Three of the cards are chosen at random, without replacement.

Find the probability that the cards do not show the letter *C*.

*Answer(c)* ..... [2]

6 (a)

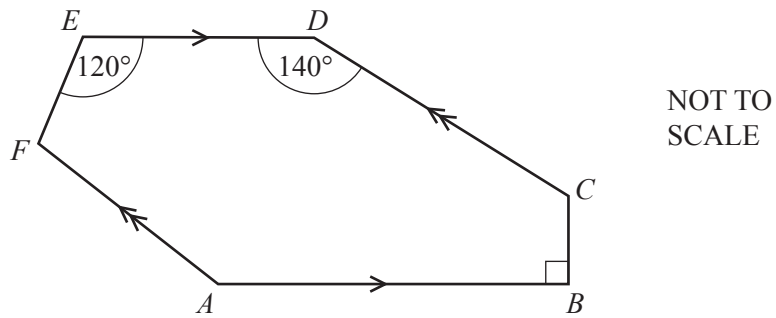

In the hexagon  $ABCDEF$ ,  $AB$  is parallel to  $ED$  and  $AF$  is parallel to  $CD$ .  
 Angle  $ABC = 90^\circ$ , angle  $CDE = 140^\circ$  and angle  $DEF = 120^\circ$ .

Calculate angle  $EFA$ .

Answer(a) Angle  $EFA = \dots\dots\dots$  [4]

(b)

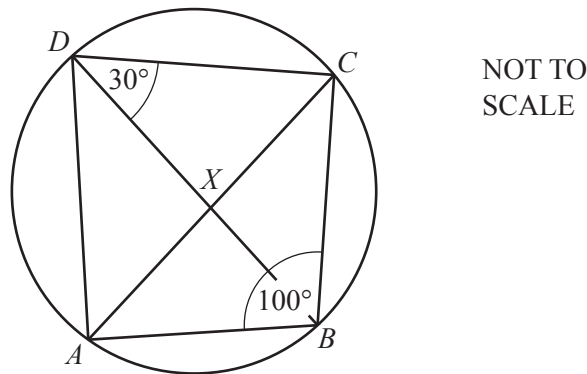

In the cyclic quadrilateral  $ABCD$ , angle  $ABC = 100^\circ$  and angle  $BDC = 30^\circ$ .  
 The diagonals intersect at  $X$ .

(i) Calculate angle  $ACB$ .

Answer(b)(i) Angle  $ACB = \dots\dots\dots$  [2]

(ii) Angle  $BXC = 89^\circ$ .

Calculate angle  $CAD$ .

Answer(b)(ii) Angle  $CAD = \dots\dots\dots$  [2]

(iii) Complete the statement.

Triangles  $AXD$  and  $BXC$  are  $\dots\dots\dots$  [1]



(c)

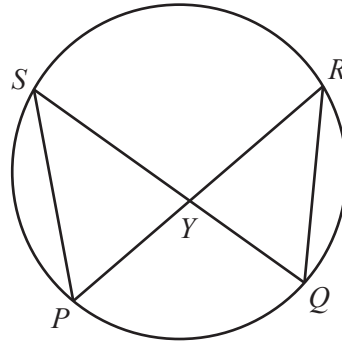

NOT TO SCALE

$P, Q, R$  and  $S$  lie on a circle.

$PR$  and  $QS$  intersect at  $Y$ .

$PS = 11$  cm,  $QR = 10$  cm and the area of triangle  $QRY = 23$  cm<sup>2</sup>.

Calculate the area of triangle  $PYS$ .

Answer(c) ..... cm<sup>2</sup> [2]

(d) A regular polygon has  $n$  sides.  
Each exterior angle is equal to  $\frac{n}{10}$  degrees.

(i) Find the value of  $n$ .

Answer(d)(i)  $n =$  ..... [3]

(ii) Find the size of an interior angle of this polygon.

Answer(d)(ii) ..... [2]

7 (a) The total surface area of a cone is given by the formula  $A = \pi rl + \pi r^2$ .

(i) Find  $A$  when  $r = 6.2$  cm and  $l = 10.8$  cm.

*Answer(a)(i)* ..... cm<sup>2</sup> [2]

(ii) Rearrange the formula to make  $l$  the subject.

*Answer(a)(ii)*  $l =$  ..... [2]

(b) (i) Irina walks 10 km at 4 km/h and then a further 8 km at 5 km/h.

Calculate Irina's average speed for the whole journey.

*Answer(b)(i)* ..... km/h [3]

(ii) Dariella walks  $x$  km at 5 km/h and then runs  $(x + 4)$  km at 10 km/h.  
The average speed of this journey is 7 km/h.

Find the value of  $x$ .  
Show all your working.

*Answer(b)(ii)*  $x =$  ..... [5]

- (c) (i) Priyantha sells her model car for \$19.80 at a profit of 20%.

Calculate the original price of the model car.

*Answer(c)(i)* \$..... [3]

- (ii) Dev sells his model car for \$ $x$  at a profit of  $y\%$ .

Find an expression, in terms of  $x$  and  $y$ , for the original price of this model car.

Write your answer as a single fraction.

*Answer(c)(ii)* \$..... [3]

---

- 8 (a) A cylindrical tank contains  $180\,000\text{ cm}^3$  of water.  
The radius of the tank is 45 cm.

Calculate the height of water in the tank.

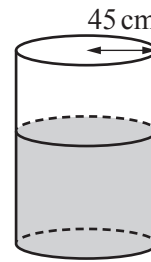

NOT TO SCALE

Answer(a) ..... cm [2]

- (b)

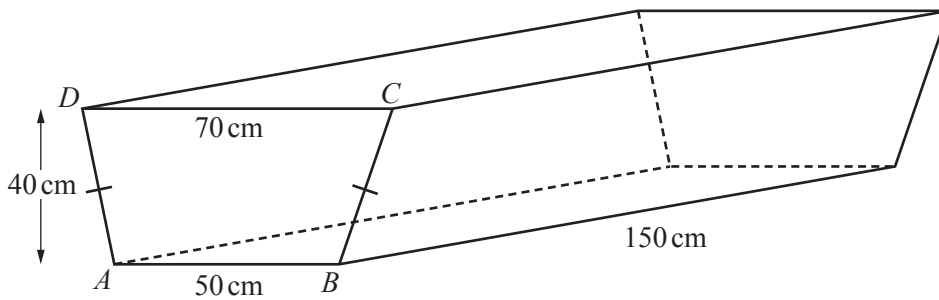

NOT TO SCALE

The diagram shows an empty tank in the shape of a horizontal prism of length 150 cm.  
The cross section of the prism is an isosceles trapezium  $ABCD$ .  
 $AB = 50\text{ cm}$ ,  $CD = 70\text{ cm}$  and the vertical height of the trapezium is 40 cm.

- (i) Calculate the volume of the tank.

Answer(b)(i) .....  $\text{cm}^3$  [3]

- (ii) Write your answer to **part (b)(i)** in litres.

Answer(b)(ii) ..... litres [1]

- (c) The  $180\,000\text{ cm}^3$  of water flows from the tank in **part (a)** into the tank in **part (b)** at a rate of  $15\text{ cm}^3/\text{s}$ .

Calculate the time this takes.  
Give your answer in hours and minutes.

Answer(c) ..... h ..... min [3]

(d)

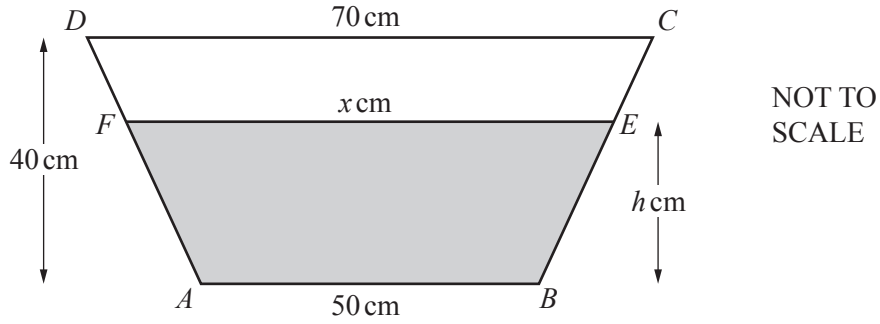

The  $180\,000\text{ cm}^3$  of water reaches the level  $EF$  as shown above.  
 $EF = x\text{ cm}$  and the height of the water is  $h\text{ cm}$ .

(i) Using the properties of similar triangles, show that  $h = 2(x - 50)$ .

*Answer(d)(i)*

[2]

(ii) Using  $h = 2(x - 50)$ , show that the shaded area, in  $\text{cm}^2$ , is  $x^2 - 2500$ .

*Answer(d)(ii)*

[1]

(iii) Find the value of  $x$ .

*Answer(d)(iii)*  $x = \dots\dots\dots$  [2]

(iv) Find the value of  $h$ .

*Answer(d)(iv)*  $h = \dots\dots\dots$  [1]

9       $\mathbf{P} = \begin{pmatrix} 2 & 3 \\ 1 & 4 \end{pmatrix}$        $\mathbf{Q} = \begin{pmatrix} 1 & 2 \\ 0 & 3 \end{pmatrix}$        $\mathbf{R} = \begin{pmatrix} 0 & u \\ 1 & v \end{pmatrix}$        $\mathbf{S} = \begin{pmatrix} w & 3 \\ 8 & 2 \end{pmatrix}$

(a) Work out  $\mathbf{PQ}$ .

*Answer(a)*       $\begin{pmatrix} & \\ & \end{pmatrix}$       [2]

(b) Find  $\mathbf{Q}^{-1}$ .

*Answer(b)*       $\begin{pmatrix} & \\ & \end{pmatrix}$       [2]

(c)  $\mathbf{PR} = \mathbf{RP}$

Find the value of  $u$  and the value of  $v$ .

*Answer(c)*  $u = \dots\dots\dots$   
 $v = \dots\dots\dots$  [3]

(d) The determinant of  $\mathbf{S}$  is 0.

Find the value of  $w$ .

*Answer(d)*  $w = \dots\dots\dots$  [2]

10       $f(x) = 2x - 1$                    $g(x) = x^2 + x$                    $h(x) = \frac{2}{x}, x \neq 0$

(a) Find  $ff(3)$ .

*Answer(a)* ..... [2]

(b) Find  $gf(x)$ , giving your answer in its simplest form.

*Answer(b)* ..... [3]

(c) Find  $f^{-1}(x)$ .

*Answer(c)*  $f^{-1}(x) =$  ..... [2]

(d) Find  $h(x) + h(x + 2)$ , giving your answer as a single fraction.

*Answer(d)* ..... [4]

---

**Question 11 is printed on the next page.**

- 11 The first four terms of sequences A, B, C and D are shown in the table.

Sequence	1st term	2nd term	3rd term	4th term	5th term	<i>n</i> th term
A	$\frac{1}{3}$	$\frac{2}{4}$	$\frac{3}{5}$	$\frac{4}{6}$		
B	3	4	5	6		
C	-1	0	1	2		
D	-3	0	5	12		

- (a) Complete the table.

[8]

- (b) Which term in sequence A is equal to  $\frac{36}{37}$ ?

*Answer(b)* ..... [2]

- (c) Which term in sequence D is equal to 725?

*Answer(c)* ..... [2]

Permission to reproduce items where third-party owned material protected by copyright is included has been sought and cleared where possible. Every reasonable effort has been made by the publisher (UCLES) to trace copyright holders, but if any items requiring clearance have unwittingly been included, the publisher will be pleased to make amends at the earliest possible opportunity.

To avoid the issue of disclosure of answer-related information to candidates, all copyright acknowledgements are reproduced online in the Cambridge International Examinations Copyright Acknowledgements Booklet. This is produced for each series of examinations and is freely available to download at [www.cie.org.uk](http://www.cie.org.uk) after the live examination series.

Cambridge International Examinations is part of the Cambridge Assessment Group. Cambridge Assessment is the brand name of University of Cambridge Local Examinations Syndicate (UCLES), which is itself a department of the University of Cambridge.