



UNIVERSITY OF CAMBRIDGE INTERNATIONAL EXAMINATIONS
General Certificate of Education Advanced Level

MATHEMATICS

9709/51

Paper 5 Mechanics 2 (M2)

October/November 2011

1 hour 15 minutes

Additional Materials: Answer Booklet/Paper
Graph Paper
List of Formulae (MF9)



READ THESE INSTRUCTIONS FIRST

If you have been given an Answer Booklet, follow the instructions on the front cover of the Booklet.

Write your Centre number, candidate number and name on all the work you hand in.

Write in dark blue or black pen.

You may use a soft pencil for any diagrams or graphs.

Do not use staples, paper clips, highlighters, glue or correction fluid.

Answer **all** the questions.

Give non-exact numerical answers correct to 3 significant figures, or 1 decimal place in the case of angles in degrees, unless a different level of accuracy is specified in the question.

Where a numerical value for the acceleration due to gravity is needed, use 10 m s^{-2} .

The use of an electronic calculator is expected, where appropriate.

You are reminded of the need for clear presentation in your answers.

At the end of the examination, fasten all your work securely together.

The number of marks is given in brackets [] at the end of each question or part question.

The total number of marks for this paper is 50.

Questions carrying smaller numbers of marks are printed earlier in the paper, and questions carrying larger numbers of marks later in the paper.

This document consists of **3** printed pages and **1** blank page.



1

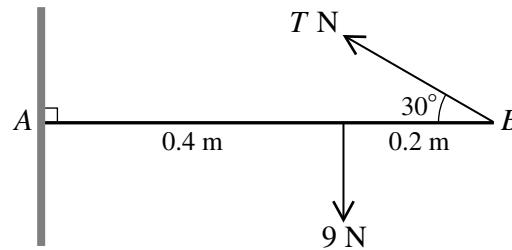

A non-uniform rod AB , of length 0.6 m and weight 9 N , has its centre of mass 0.4 m from A . The end A of the rod is in contact with a rough vertical wall. The rod is held in equilibrium, perpendicular to the wall, by means of a light string attached to B . The string is inclined at 30° to the horizontal. The tension in the string is $T\text{ N}$ (see diagram).

(i) Calculate T . [2]

(ii) Find the least possible value of the coefficient of friction at A . [3]

2

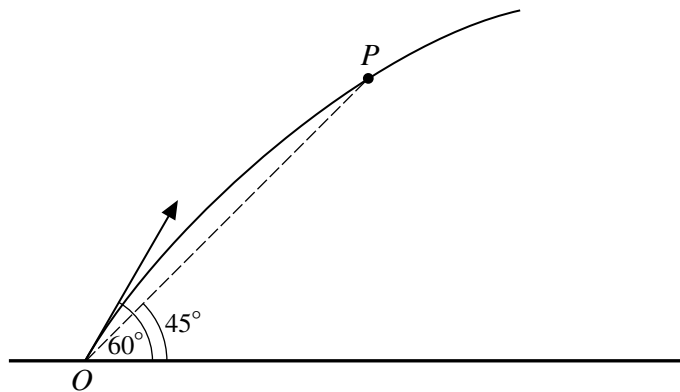

A particle P is projected from a point O at an angle of 60° above horizontal ground. At an instant 0.6 s after projection, the angle of elevation of P from O is 45° (see diagram).

(i) Show that the speed of projection of P is 8.20 m s^{-1} , correct to 3 significant figures. [4]

(ii) Calculate the time after projection when the direction of motion of P is 45° above the horizontal. [3]

3 One end of a light elastic string of natural length 0.4 m and modulus of elasticity 20 N is attached to a fixed point O . The other end of the string is attached to a particle P of mass 0.25 kg . P hangs in equilibrium below O .

(i) Calculate the distance OP . [2]

The particle P is raised, and is released from rest at O .

(ii) Calculate the speed of P when it passes through the equilibrium position. [3]

(iii) Calculate the greatest value of the distance OP in the subsequent motion. [3]

- 4 A uniform solid cylinder has radius 0.7 m and height h m. A uniform solid cone has base radius 0.7 m and height 2.4 m. The cylinder and the cone both rest in equilibrium each with a circular face in contact with a horizontal plane. The plane is now tilted so that its inclination to the horizontal, θ° , is increased gradually until the cone is about to topple.

(i) Find the value of θ at which the cone is about to topple. [2]

(ii) Given that the cylinder does not topple, find the greatest possible value of h . [2]

The plane is returned to a horizontal position, and the cone is fixed to one end of the cylinder so that the plane faces coincide. It is given that the weight of the cylinder is three times the weight of the cone. The curved surface of the cone is placed on the horizontal plane (see diagram).

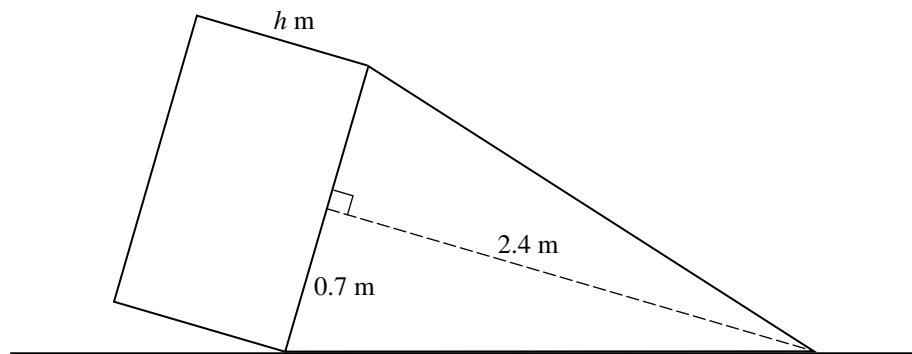

(iii) Given that the solid immediately topples, find the least possible value of h . [5]

- 5 A ball of mass 0.05 kg is released from rest at a height h m above the ground. At time t s after its release, the downward velocity of the ball is v m s⁻¹. Air resistance opposes the motion of the ball with a force of magnitude $0.01v$ N.

(i) Show that $\frac{dv}{dt} = 10 - 0.2v$. Hence find v in terms of t . [6]

(ii) Given that the ball reaches the ground when $t = 2$, calculate h . [4]

- 6 A smooth bead B of mass 0.3 kg is threaded on a light inextensible string of length 0.9 m. One end of the string is attached to a fixed point A , and the other end of the string is attached to a fixed point C which is vertically below A . The tension in the string is T N, and the bead rotates with angular speed ω rad s⁻¹ in a horizontal circle about the vertical axis through A and C .

(i) Given that B moves in a circle with centre C and radius 0.2 m, calculate ω , and hence find the kinetic energy of B . [5]

(ii) Given instead that angle $ABC = 90^\circ$, and that AB makes an angle $\tan^{-1}(\frac{1}{2})$ with the vertical, calculate T and ω . [6]

BLANK PAGE

Permission to reproduce items where third-party owned material protected by copyright is included has been sought and cleared where possible. Every reasonable effort has been made by the publisher (UCLES) to trace copyright holders, but if any items requiring clearance have unwittingly been included, the publisher will be pleased to make amends at the earliest possible opportunity.

University of Cambridge International Examinations is part of the Cambridge Assessment Group. Cambridge Assessment is the brand name of University of Cambridge Local Examinations Syndicate (UCLES), which is itself a department of the University of Cambridge.