

CAMBRIDGE INTERNATIONAL EXAMINATIONS
General Certificate of Education Advanced Subsidiary Level
General Certificate of Education Advanced Level

MATHEMATICS

9709/1

PAPER 1 Pure Mathematics 1 (P1)

OCTOBER/NOVEMBER SESSION 2002

1 hour 45 minutes

Additional materials:
Answer paper
Graph paper
List of Formulae (MF9)

TIME 1 hour 45 minutes

INSTRUCTIONS TO CANDIDATES

Write your name, Centre number and candidate number in the spaces provided on the answer paper/answer booklet.

Answer **all** the questions.

Give non-exact numerical answers correct to 3 significant figures, or 1 decimal place in the case of angles in degrees, unless a different level of accuracy is specified in the question.

INFORMATION FOR CANDIDATES

The number of marks is given in brackets [] at the end of each question or part question.

The total number of marks for this paper is 75.

Questions carrying smaller numbers of marks are printed earlier in the paper, and questions carrying larger numbers of marks later in the paper.

The use of an electronic calculator is expected, where appropriate.

You are reminded of the need for clear presentation in your answers.

This question paper consists of 5 printed pages and 3 blank pages.

1 Find the value of the term which is independent of x in the expansion of $\left(x + \frac{3}{x}\right)^4$. [3]

2 A geometric progression, for which the common ratio is positive, has a second term of 18 and a fourth term of 8. Find

(i) the first term and the common ratio of the progression, [3]

(ii) the sum to infinity of the progression. [2]

3

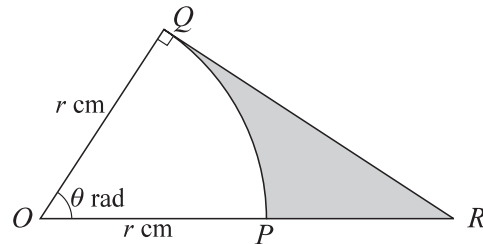

In the diagram, OPQ is a sector of a circle, centre O and radius r cm. Angle $QOP = \theta$ radians. The tangent to the circle at Q meets OP extended at R .

(i) Show that the area, A cm², of the shaded region is given by $A = \frac{1}{2}r^2(\tan \theta - \theta)$. [2]

(ii) In the case where $\theta = 0.8$ and $r = 15$, evaluate the length of the perimeter of the shaded region. [4]

4 The gradient at any point (x, y) on a curve is $\sqrt{1 + 2x}$. The curve passes through the point $(4, 11)$. Find

(i) the equation of the curve, [4]

(ii) the point at which the curve intersects the y -axis. [2]

5 (i) Show that the equation $3 \tan \theta = 2 \cos \theta$ can be expressed as

$$2 \sin^2 \theta + 3 \sin \theta - 2 = 0. \quad [3]$$

(ii) Hence solve the equation $3 \tan \theta = 2 \cos \theta$, for $0^\circ \leq \theta \leq 360^\circ$. [3]

6

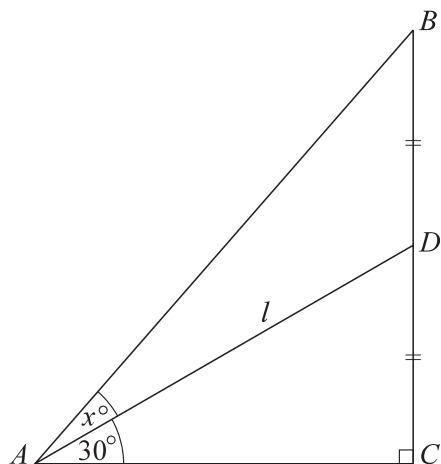

In the diagram, triangle ABC is right-angled and D is the mid-point of BC . Angle $DAC = 30^\circ$ and angle $BAD = x^\circ$. Denoting the length of AD by l ,

(i) express each of AC and BC exactly in terms of l , and show that $AB = \frac{1}{2}l\sqrt{7}$, [4]

(ii) show that $x = \tan^{-1}\left(\frac{2}{\sqrt{3}}\right) - 30$. [2]

7 Given that $\mathbf{a} = \begin{pmatrix} 2 \\ -2 \\ 1 \end{pmatrix}$, $\mathbf{b} = \begin{pmatrix} 2 \\ 6 \\ 3 \end{pmatrix}$ and $\mathbf{c} = \begin{pmatrix} p \\ p \\ p+1 \end{pmatrix}$, find

(i) the angle between the directions of \mathbf{a} and \mathbf{b} , [4]

(ii) the value of p for which \mathbf{b} and \mathbf{c} are perpendicular. [3]

8 A curve has equation $y = x^3 + 3x^2 - 9x + k$, where k is a constant.

(i) Write down an expression for $\frac{dy}{dx}$. [2]

(ii) Find the x -coordinates of the two stationary points on the curve. [2]

(iii) Hence find the two values of k for which the curve has a stationary point on the x -axis. [3]

9

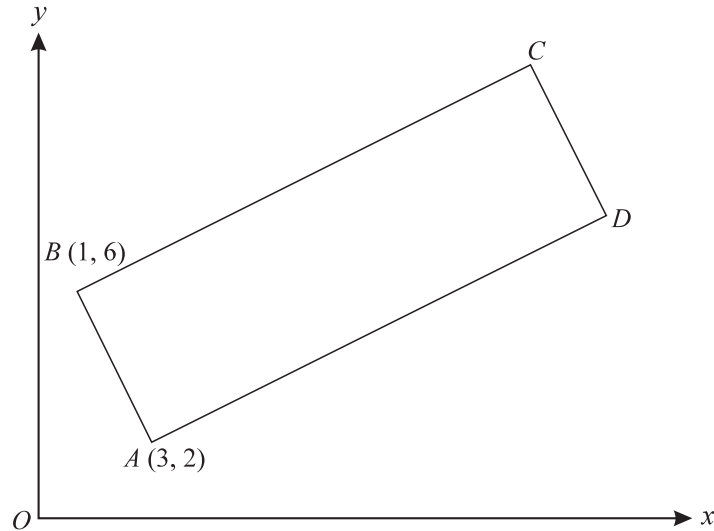

The diagram shows a rectangle $ABCD$, where A is $(3, 2)$ and B is $(1, 6)$.

(i) Find the equation of BC . [4]

Given that the equation of AC is $y = x - 1$, find

(ii) the coordinates of C , [2]

(iii) the perimeter of the rectangle $ABCD$. [3]

10

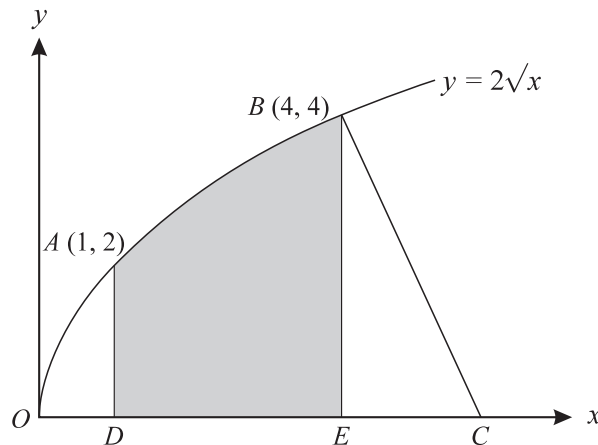

The diagram shows the points $A(1, 2)$ and $B(4, 4)$ on the curve $y = 2\sqrt{x}$. The line BC is the normal to the curve at B , and C lies on the x -axis. Lines AD and BE are perpendicular to the x -axis.

(i) Find the equation of the normal BC . [4]

(ii) Find the area of the shaded region. [4]

- 11** (i) Express $2x^2 + 8x - 10$ in the form $a(x + b)^2 + c$. [3]
- (ii) For the curve $y = 2x^2 + 8x - 10$, state the least value of y and the corresponding value of x . [2]
- (iii) Find the set of values of x for which $y \geq 14$. [3]

Given that $f : x \mapsto 2x^2 + 8x - 10$ for the domain $x \geq k$,

- (iv) find the least value of k for which f is one-one, [1]
- (v) express $f^{-1}(x)$ in terms of x in this case. [3]

BLANK PAGE

BLANK PAGE

BLANK PAGE