

UNIVERSITY OF CAMBRIDGE INTERNATIONAL EXAMINATIONS
General Certificate of Education
Advanced Subsidiary Level and Advanced Level

HIGHER MATHEMATICS
MATHEMATICS

8719/05
9709/05

Paper 5 Mechanics 2 (M2)

May/June 2004

1 hour 15 minutes

Additional materials: Answer Booklet/Paper
Graph paper
List of Formulae (MF9)

READ THESE INSTRUCTIONS FIRST

If you have been given an Answer Booklet, follow the instructions on the front cover of the Booklet.
Write your Centre number, candidate number and name on all the work you hand in.
Write in dark blue or black pen on both sides of the paper.
You may use a soft pencil for any diagrams or graphs.
Do not use staples, paper clips, highlighters, glue or correction fluid.

Answer **all** the questions.

Give non-exact numerical answers correct to 3 significant figures, or 1 decimal place in the case of angles in degrees, unless a different level of accuracy is specified in the question.

Where a numerical value for the acceleration due to gravity is needed, use 10 m s^{-2} .

At the end of the examination, fasten all your work securely together.

The number of marks is given in brackets [] at the end of each question or part question.

The total number of marks for this paper is 50.

Questions carrying smaller numbers of marks are printed earlier in the paper, and questions carrying larger numbers of marks later in the paper.

The use of an electronic calculator is expected, where appropriate.

You are reminded of the need for clear presentation in your answers.

This document consists of **4** printed pages.



1



A uniform rigid plank has mass 10 kg and length 4 m. The plank has 0.9 m of its length in contact with a horizontal platform. A man M of mass 75 kg stands on the end of the plank which is in contact with the platform. A child C of mass 25 kg walks on to the overhanging part of the plank (see diagram). Find the distance between the man and the child when the plank is on the point of tilting. [4]

2

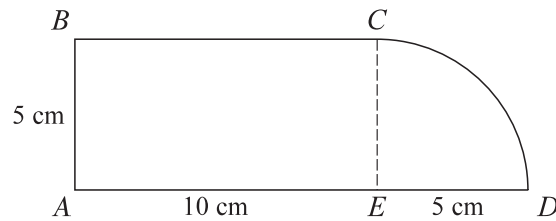

A uniform lamina $ABCDE$ consists of a rectangular part with sides 5 cm and 10 cm, and a part in the form of a quarter of a circle of radius 5 cm, as shown in the diagram.

(i) Show that the distance of the centre of mass of the part CDE of the lamina is $\frac{20}{3\pi}$ cm from CE . [2]

(ii) Find the distance of the centre of mass of the lamina $ABCDE$ from the edge AB . [4]

3

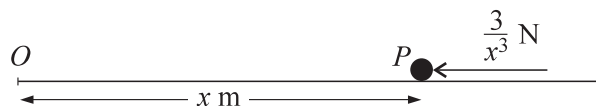

A particle P of mass 0.6 kg moves in a straight line on a smooth horizontal surface. A force of magnitude $\frac{3}{x^3}$ newtons acts on the particle in the direction from P to O , where O is a fixed point of the surface and x m is the distance OP (see diagram). The particle P is released from rest at the point where $x = 10$. Find the speed of P when $x = 2.5$. [7]

4

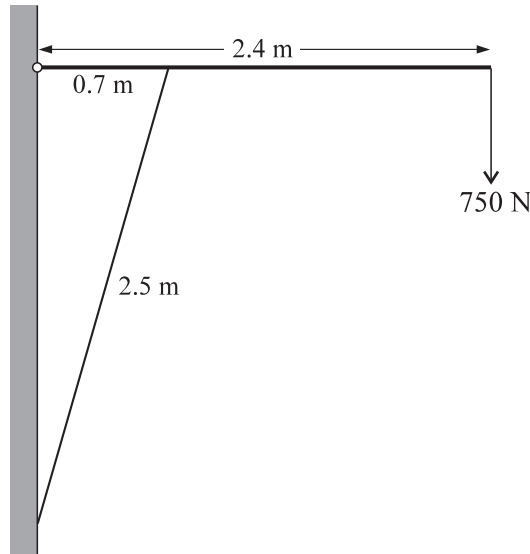

A uniform beam has length 2.4 m and weight 68 N. The beam is hinged at a fixed point of a vertical wall, and held in a horizontal position by a light rod of length 2.5 m. One end of the rod is attached to the beam at a point 0.7 m from the wall, and the other end of the rod is attached to the wall at a point vertically below the hinge. The beam carries a load of 750 N at its end (see diagram).

- (i) Find the force in the rod. [4]

The components of the force exerted by the hinge on the beam are X N horizontally towards the wall and Y N vertically downwards.

- (ii) Find the values of X and Y . [3]

5



One end of a light elastic string of natural length 4 m and modulus of elasticity 200 N is attached to a fixed point A . The other end is attached to the end C of a uniform rod CD of mass 10 kg. One end of another light elastic string, which is identical to the first, is attached to a fixed point B and the other end is attached to D , as shown in the diagram. The distance AB is equal to the length of the rod, and AB is horizontal. The rod is released from rest with C at A and D at B . While the strings are taut, the speed of the rod is v m s⁻¹ when the rod is at a distance of $(4 + x)$ m below AB .

- (i) Show that $v^2 = 10(8 + 2x - x^2)$. [5]

- (ii) Hence find the value of x when the rod is at its lowest point. [2]

- 6** A particle is projected from a point O on horizontal ground. The velocity of projection has magnitude $V \text{ m s}^{-1}$ and direction upwards at 35° to the horizontal. The particle passes through the point M at time T seconds after the instant of projection. The point M is 2 m above the ground and at a horizontal distance of 25 m from O .
- (i) Find the values of V and T . [5]
- (ii) Find the speed of the particle as it passes through M and determine whether it is moving upwards or downwards. [4]
- 7** One end of a light inextensible string of length 0.15 m is attached to a fixed point which is above a smooth horizontal surface. A particle of mass 0.5 kg is attached to the other end of the string. The particle moves with constant speed $v \text{ m s}^{-1}$ in a horizontal circle, with the string taut and making an angle of θ° with the downward vertical.
- (i) Given that $\theta = 60$ and that the particle is not in contact with the surface, find v . [5]
- (ii) Given instead that $\theta = 45$ and $v = 0.9$, and that the particle is in contact with the surface, find
- (a) the tension in the string, [2]
- (b) the force exerted by the surface on the particle. [3]