



UNIVERSITY OF CAMBRIDGE INTERNATIONAL EXAMINATIONS
 General Certificate of Education
 Advanced Subsidiary Level and Advanced Level

CANDIDATE
 NAME

CENTRE
 NUMBER

--	--	--	--	--

CANDIDATE
 NUMBER

--	--	--	--



BIOLOGY

9700/31

Advanced Practical Skills 1

October/November 2013

2 hours

Candidates answer on the Question Paper.

Additional Materials: As listed in the Confidential Instructions.

READ THESE INSTRUCTIONS FIRST

Write your Centre number, candidate number and name on all the work you hand in.
 Write in dark blue or black ink.
 You may use a pencil for any diagrams, graphs or rough working.
 Do **not** use red ink, staples, paper clips, highlighters, glue or correction fluid.
DO NOT WRITE IN ANY BARCODES.

Answer **all** questions.
 Electronic calculators may be used.
 You may lose marks if you do not show your working or if you do not use appropriate units.

At the end of the examination, fasten all your work securely together.
 The number of marks is given in brackets [] at the end of each question or part question.

For Examiner's Use	
1	
2	
Total	

This document consists of **11** printed pages and **1** blank page.



You are reminded that you have **only one hour** for each question in the practical examination.

You should:

- read carefully through **the whole** of Question 1 and Question 2
- then plan your use of **the time** to make sure that you finish all the work that you would like to do.

You will **gain marks** for recording your results according to the instructions.

1 Agar pieces can be used to investigate diffusion.

You are required to investigate the effect of ascorbic acid (independent variable) diffusing into stained agar pieces.

As ascorbic acid, **A**, diffuses into the stained agar piece it causes the piece to decolourise (lose its blue colour).

You are provided with:

labelled	contents	hazard	volume / cm ³
A	0.10% ascorbic acid	irritant	100
W	distilled water	none	100

labelled	contents	hazard	size
U	agar block containing a blue stain	none	at least 60 mm × 40 mm

Read steps 1–6 before proceeding.

Proceed as follows:

1. You are required to dilute the 0.10% ascorbic acid, **A**, to provide a range of known concentrations using **simple dilution**.

You will need to cut the agar block, **U**, into smaller pieces as shown in Fig. 1.1. To avoid staining your skin, try not to touch the agar. You may use the blunt forceps and paper towels to handle the agar.

For
Examiner's
Use

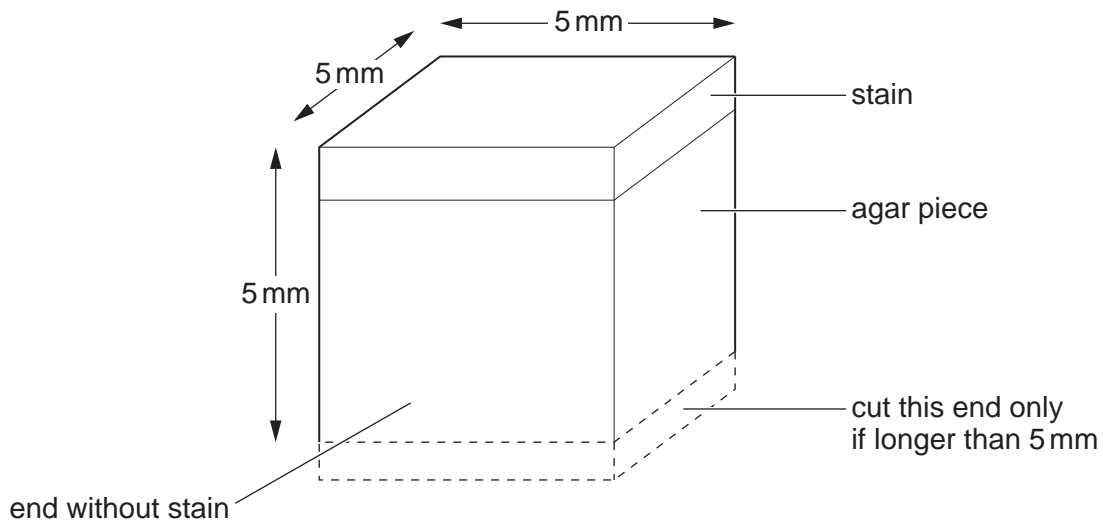

Fig. 1.1

- Place the agar block onto a damp paper towel and cut the block into identical pieces of 5 mm × 5 mm × 5 mm as shown in Fig. 1.1. *You will need to consider the number of pieces needed for each concentration of ascorbic acid you have stated in Table 1.1 on page 3.*

Fig. 1.1 shows the measurement of the agar pieces that you need.

- Put the prepared agar pieces into each of the concentrations of ascorbic acid. Immediately start timing.
- Gently stir the contents of each beaker or container at regular intervals.
- Record the time taken for the pieces to decolourise. After 15 minutes, if any agar piece has not decolourised, **stop timing**, and record 'more than 900'.

(ii) Prepare the space below and record your results.

For
Examiner's
Use

[5]

(iii) Identify **two** significant sources of error in this investigation.

.....
.....
.....
.....

[2]

(iv) Describe **three** modifications to this investigation which would improve the confidence in your results.

.....
.....
.....
.....
.....
.....

[3]

A student investigated measuring the concentration of ascorbic acid in different solutions by using a colour change with an indicator.
The greater the volume of indicator added the greater the concentration of ascorbic acid in the solution.

For
Examiner's
Use

The student's results are shown in Table 1.3.

Table 1.3

percentage concentration of ascorbic acid	volume of indicator / cm ³
0.10	0.25
0.30	0.75
0.60	1.45
0.70	1.75
1.00	2.50

(b) (i) Plot a graph of the data shown in Table 1.3.

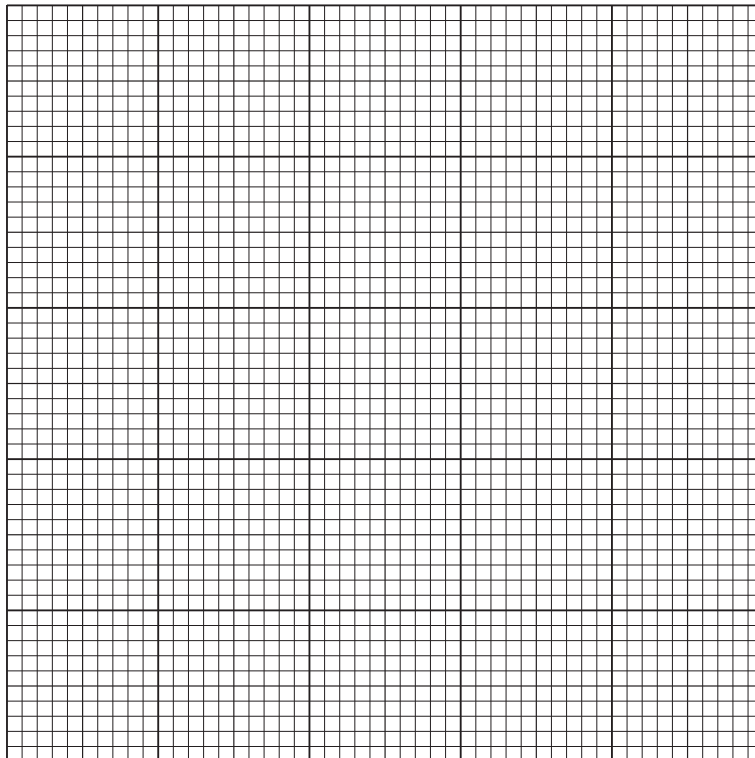

[4]

(ii) Use your graph to estimate the concentration of ascorbic acid present in a solution that required 0.875 cm³ of indicator.

Show clearly on your graph how you obtained the ascorbic acid concentration.

concentration of ascorbic acid[2]

[Total: 19]

2 **J1** is a slide of a transverse section through a tubular organ which is involved in transport.

(a) (i) Draw a large plan diagram of the part of the tube on **J1** indicated by the shaded sector in Fig. 2.1.

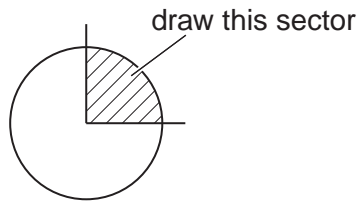

Fig. 2.1

On your diagram, use a label line and label to show the muscle tissue.

[5]

(ii) State **one** observable feature of the tube on **J1** which supports the conclusion that the tube is involved in transport.
Explain how this feature supports the conclusion.

.....

.....

.....

.....

.....

..... [2]

Fig. 2.2 is a photomicrograph of blood cells in a field of view.

For
Examiner's
Use

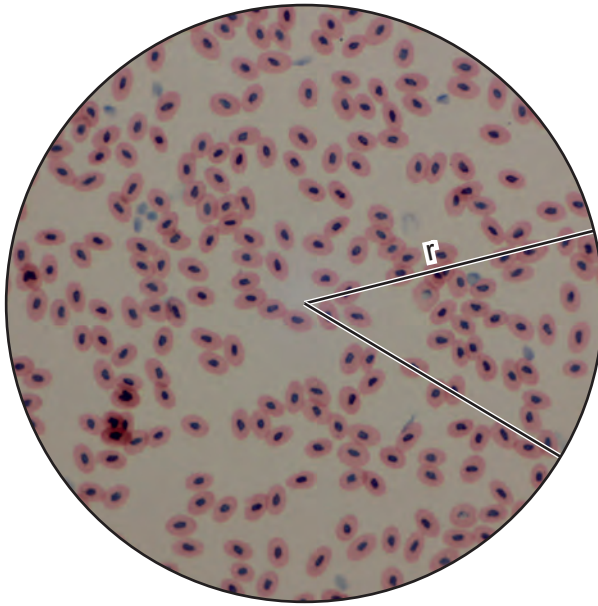

magnification x 200

Fig. 2.2

Fig. 2.2 shows many blood cells. There are too many red blood cells to count, so the technique of sampling may be used to estimate the number of red blood cells in the field of view.

A sample should be counted in a known smaller area and then the result multiplied to obtain an estimate of the number of red blood cells in the whole field of view.

For example, if the number of red blood cells is counted in an eighth of the area of the field of view then this number would be multiplied by 8 to obtain the total number in the area of the field of view.

(b) (i) Count and record the **sample number** of red blood cells in the eighth of the area of the field of view.

- Mark clearly **on Fig. 2.2** each of the red blood cells counted.
- Estimate the number of red blood cells in the whole field of view.

You will lose marks if you do not show your working.

number of red blood cells in the field of view [2]

To find the area of the field of view you need to calculate the **actual length** of line **r**, the radius of the circle, in mm.

For
Examiner's
Use

- (ii) Use the magnification on Fig. 2.2 to calculate the **actual length** of line **r** in mm.

actual length mm

Use the actual length of line **r** to calculate the area of the field of view using the formula for the area of a circle:

area of a circle πr^2
 $\pi = 3.14$
 $r =$ radius of field of view

area of field of view mm^2 [2]

- (iii) Calculate the number of red blood cells per mm^2 using your answers in **(b)(i)** and **(b)(ii)**.

You will lose marks if you do not show your working.

number of red blood cells mm^{-2} [2]

A group of people climbed a mountain. They started at sea level (0.0km) and reached a height of 6km above sea level in 60 days.

For
Examiner's
Use

The average number of red blood cells per cm^3 of blood was calculated for the group of people at the start of the climb and at 20 day intervals.

The data is shown in Table 2.1.

Table 2.1

days	height above sea level /km	average number of red blood cells for the group / millions per cm^3
0	0.0	4.7
20	3.0	5.5
40	4.5	6.3
60	6.0	6.5

(iv) Describe the trend in the average number of red blood cells with height above sea level and explain the advantages of this trend.

.....

.....

.....

.....

.....

.....

.....

..... [3]

Fig. 2.3 is a photomicrograph of blood from a different organism.

*For
Examiner's
Use*

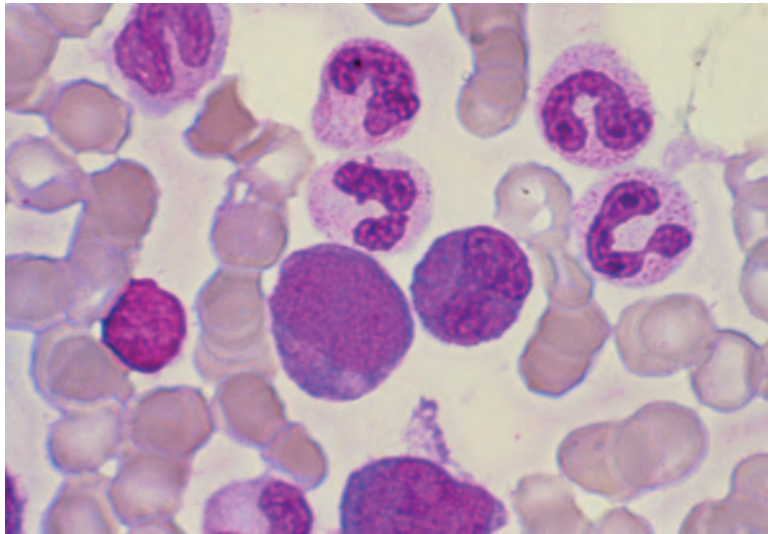

Fig. 2.3

- (c) Make a drawing of white blood cells as observed in Fig. 2.3 made up of:
- **two** cells of one type of white blood cell
 - **two** cells of a different type of white blood cell.

The drawings should show any differences in size (linear magnification) observed between each type of cell.

On your drawing, use a label line and label to show one nucleus.

[5]

[Total: 21]

BLANK PAGE

Copyright Acknowledgements:

Question 2 Fig. 2.3 © BIOPHOTO ASSOCIATES/SCIENCE PHOTO LIBRARY.

Permission to reproduce items where third-party owned material protected by copyright is included has been sought and cleared where possible. Every reasonable effort has been made by the publisher (UCLES) to trace copyright holders, but if any items requiring clearance have unwittingly been included, the publisher will be pleased to make amends at the earliest possible opportunity.

University of Cambridge International Examinations is part of the Cambridge Assessment Group. Cambridge Assessment is the brand name of University of Cambridge Local Examinations Syndicate (UCLES), which is itself a department of the University of Cambridge.