

You have been supplied with the following source files:

Assessment.csv
MailMergeTemplate.rtf
MarkConversionTask.html

Create a folder called **Examination**_centre number_candidate number
e.g. Examination_ZZ999_9999
You must save all your work in this folder.

Copy the source files into your *Examination* folder.
Do **not** delete these files when submitting your work.

You must use the most efficient methods and all work produced must be of a professional standard and contain your candidate details.

1 Open **Assessment.csv** to inspect the data.

The file contains the end of year results for the module tests for a group of students.

In a spreadsheet application use the data to create a worksheet to match the layout shown below.

Save the workbook as **Results_** followed by your centre number_ candidate number
e.g. Results_ZZ999_9999

	A	B	C	D	E	F	G	H	I	J	K	L	M	N
1														
2	End of year module results				Grade Thresholds				Number of each grade					
3					A	B	C		A	B	C	Fails		
4					90	70	40							
5														
6			Marks						Grade awarded					
7	Forename	Surname	Programming	Computer Systems	Information Systems	Data Modelling	Web Technologies		Programming	Computer Systems	Information Systems	Data Modelling	Web Technologies	Passes
8	Livia	Barese	95	38	41	89	90							
9	Curzio	Baresi	45	87	72	39	36							
10	Lorna	Calabrese	42	38	67	37	91							
11	Rosina	Cattaneo	98	96	41	37	99							
12	Nino	De Luca	15	97	35	54	36							
13	Immacolata	Endrizzi	28	38	23	54	55							
14	Tranquillo	Ferri	57	64	16	89	52							

Using the Grade Thresholds as shown in cells E3:G4, enter formulae to display the grade earned by each student for each module by applying the following rules:

- students who score 90 marks or above are awarded an A grade
- students who score between 70 and 89 marks (inclusive) are awarded a B grade
- students who score between 40 and 69 marks (inclusive) are awarded a C grade
- students who score less than 40 marks or are recorded as absent (abs) are awarded an F grade.

For example, this screenshot shows the correct grades awarded for the first student.

	A	B	C	D	E	F	G	H	I	J	K	L	M	N
1														
2	End of year module results				Grade Thresholds			Number of each grade						
3					A	B	C	A	B	C	Fails			
4					90	70	40							
5														
6			Marks					Grade awarded						
	Forename	Surname	Programming	Computer Systems	Information Systems	Data Modelling	Web Technologies	Programming	Computer Systems	Information Systems	Data Modelling	Web Technologies	Passes	
7														
8	Livia	Barese	95	38	41	89	90	A	F	C	B	A		

Re-save the workbook.

Format cells in the range I8:M41 so that cells that display grades A, B or C are coloured green to indicate a Pass grade. Format cells that display grade F to be coloured red to indicate a Fail grade.

In cells N8:N41 enter formulae to display the number of Pass grades achieved by each student.

In cells I4:L4 enter formulae to display the number of each grade awarded.

Re-save the workbook.

In cells P6:U12 create the following table formatted as shown:

	Modules				
	Programming	Computer Systems	Information Systems	Data Modelling	Web Technologies
Number of A grades					
Number of B grades					
Number of C grades					
Number of Passes					
Number of Fails					

Enter formulae to complete the table.

Re-save the workbook.

Create a single chart to display the number of passes and fails for all modules. Choose a chart type that best compares the results for each module.

Add appropriate titles and labels to the chart.

Export only the chart in **portable document format** (pdf) as **ModComp1**

Change the grade thresholds to match the following:

Grade Thresholds		
A	B	C
87	65	37

Re-export the chart in **portable document format** (pdf) as **ModComp2**

Re-save the workbook.

[35]

- 2 Use the **MailMergeTemplate.rtf** file to merge letters to students notifying them of their marks and grades for each module.

Insert the name fields where specified and display the marks and grades for each module for that student in the first table.

Insert the number of passes and the number of modules failed by the student in the second table.

Where indicated, insert conditional text to satisfy the following conditions:

- For students with no fail grades the conditional text should read:
Congratulations for a successful year.
- For students with a single fail grade the conditional text should read:
Please contact your personal tutor to arrange a resit for: <name of module failed>
- For students with more than one fail grade the conditional text should read:
Please contact your personal tutor to discuss your future.

Save the merge document as **NotifyMergeDoc_** followed by your centre number_candidate number
e.g. NotifyMergeDoc_ZZ999_9999

Carry out the merge and save the letters as **Notifications_** followed by your centre number_candidate number
e.g. Notifications_ZZ999_9999

[15]

- 3 In a vector graphics application, re-create the panel below keeping the proportions of the text, lights and sockets. Do **not** include the dimensions in your image.

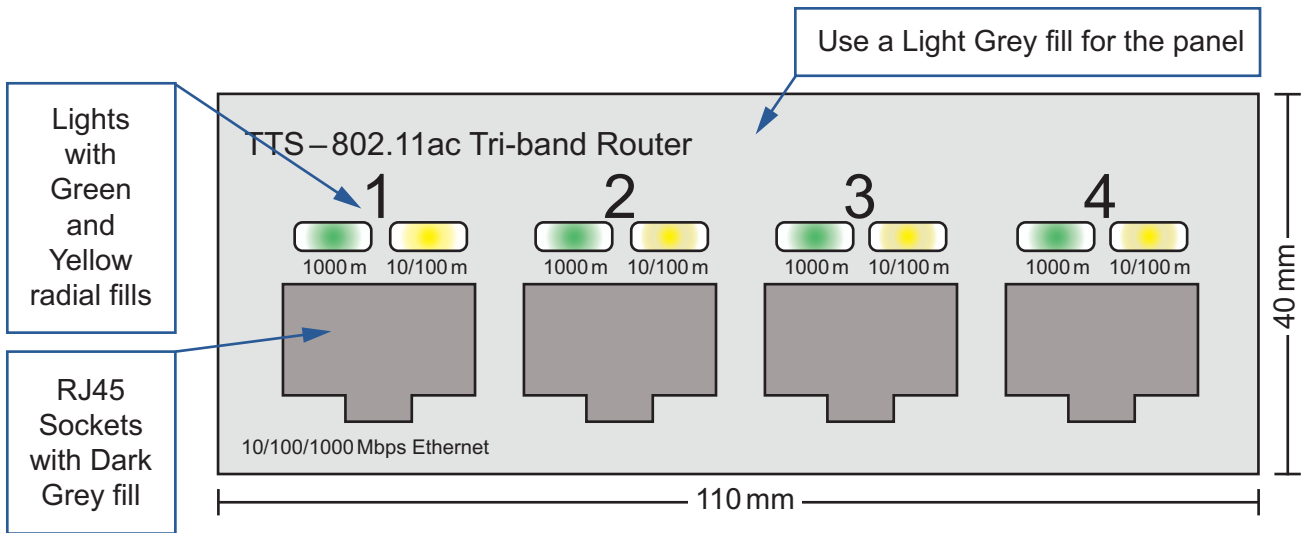

Save the image in **scalable vector graphics** (svg) format as **Panel_** followed by your centre number_candidate number
e.g. Panel_ZZ999_9999

Skew the panel image and use it to create the image shown here.

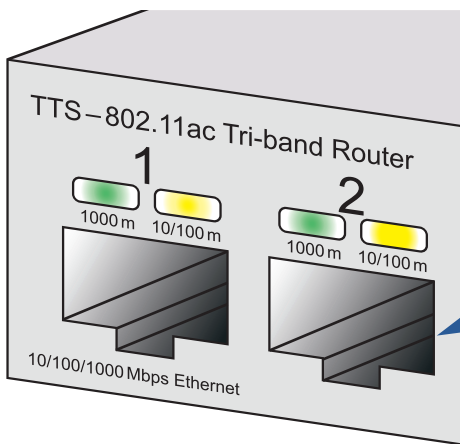
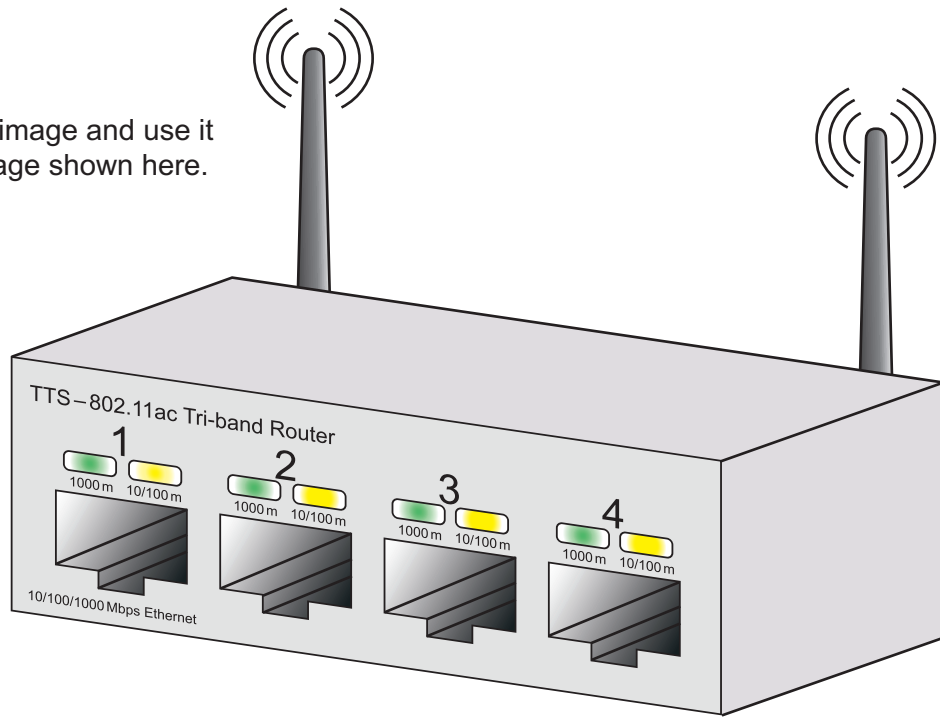

Use a gradient fill and add parallel lines to each socket to create the impression of depth

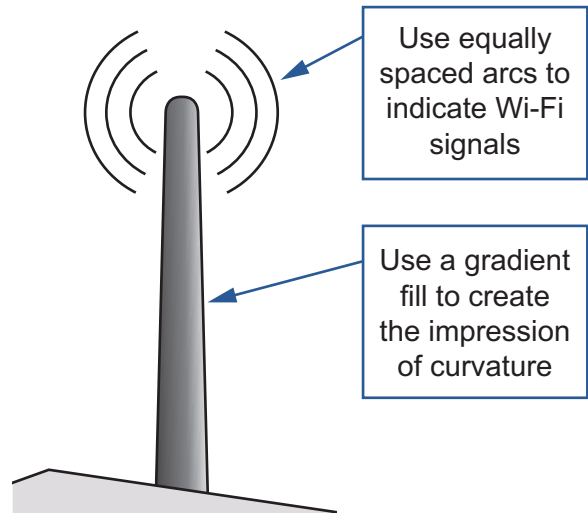

Use equally spaced arcs to indicate Wi-Fi signals

Use a gradient fill to create the impression of curvature

Save the image in **scalable vector graphics** (svg) format as **Router_** followed by your centre number_candidate number
e.g. Router_ZZ999_9999

[35]

- 4 Create an animation of Wi-Fi waves continually radiating from the tip of the antenna.

Set the frame size as 250 x 250 pixels. Keep the proportions as shown.

The animation must develop as shown. Each arc must take 1 second to grow and disappear.

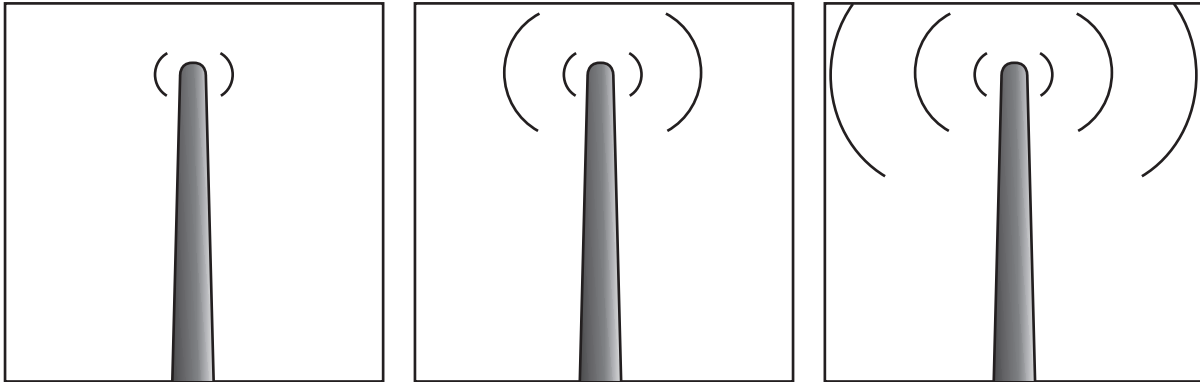

Save the animation as an **animated gif** named **Wi-Fi_** followed by your centre number_candidate number

e.g. Wi-Fi_ZZ999_9999

[10]

- 5 Open the **MarkConversionTask.html** file in a text editor.

Add JavaScript code to prompt the user to enter a mark and display the mark entered and the correct grade using the text:

For <Number of marks entered> marks the grade awarded is: <Grade awarded>

Students who score:

- 87 marks or above are awarded an A grade
- between 65 and 86 marks (inclusive) are awarded a B grade
- between 37 and 64 marks (inclusive) are awarded a C grade
- less than 37 marks or are recorded as absent (abs) are awarded an F grade.

For example, if the user entered 68 marks the page must display:

For 68 marks the grade awarded is: B

Insert programmer comments to explain important parts of your code.

Save the page as **MarkConversion_** followed by your centre number_candidate number

e.g. MarkConversion_ZZ999_9999

[15]

BLANK PAGE

BLANK PAGE

BLANK PAGE

Permission to reproduce items where third-party owned material protected by copyright is included has been sought and cleared where possible. Every reasonable effort has been made by the publisher (UCLES) to trace copyright holders, but if any items requiring clearance have unwittingly been included, the publisher will be pleased to make amends at the earliest possible opportunity.

To avoid the issue of disclosure of answer-related information to candidates, all copyright acknowledgements are reproduced online in the Cambridge Assessment International Education Copyright Acknowledgements Booklet. This is produced for each series of examinations and is freely available to download at www.cambridgeinternational.org after the live examination series.

Cambridge Assessment International Education is part of the Cambridge Assessment Group. Cambridge Assessment is the brand name of the University of Cambridge Local Examinations Syndicate (UCLES), which itself is a department of the University of Cambridge.