



Pearson

Mark Scheme (Results)

Summer 2017

Pearson Edexcel GCE In Chemistry
(6CH02/01)

Edexcel and BTEC Qualifications

Edexcel and BTEC qualifications come from Pearson, the world's leading learning company. We provide a wide range of qualifications including academic, vocational, occupational and specific programmes for employers. For further information, please visit our website at www.edexcel.com.

Our website subject pages hold useful resources, support material and live feeds from our subject advisors giving you access to a portal of information. If you have any subject specific questions about this specification that require the help of a subject specialist, you may find our Ask The Expert email service helpful.

www.edexcel.com/contactus

Pearson: helping people progress, everywhere

Our aim is to help everyone progress in their lives through education. We believe in every kind of learning, for all kinds of people, wherever they are in the world. We've been involved in education for over 150 years, and by working across 70 countries, in 100 languages, we have built an international reputation for our commitment to high standards and raising achievement through innovation in education. Find out more about how we can help you and your students at: www.pearson.com/uk

Summer 2017

Publications Code 6CH02_01_ 1706_MS

All the material in this publication is copyright

© Pearson Education Ltd 2017

General Marking Guidance

- All candidates must receive the same treatment. Examiners must mark the first candidate in exactly the same way as they mark the last.
- Mark schemes should be applied positively. Candidates must be rewarded for what they have shown they can do rather than penalised for omissions.
- Examiners should mark according to the mark scheme not according to their perception of where the grade boundaries may lie.
- There is no ceiling on achievement. All marks on the mark scheme should be used appropriately.
- All the marks on the mark scheme are designed to be awarded. Examiners should always award full marks if deserved, i.e. if the answer matches the mark scheme. Examiners should also be prepared to award zero marks if the candidate's response is not worthy of credit according to the mark scheme.
- Where some judgement is required, mark schemes will provide the principles by which marks will be awarded and exemplification may be limited.
- When examiners are in doubt regarding the application of the mark scheme to a candidate's response, the team leader must be consulted.
- Crossed out work should be marked UNLESS the candidate has replaced it with an alternative response.
- Mark schemes will indicate within the table where, and which strands of QWC, are being assessed. The strands are as follows:
 - i) ensure that text is legible and that spelling, punctuation and grammar are accurate so that meaning is clear
 - ii) select and use a form and style of writing appropriate to purpose and to complex subject matter
 - iii) organise information clearly and coherently, using specialist vocabulary when appropriate

Using the Mark Scheme

Examiners should look for qualities to reward rather than faults to penalise. This does NOT mean giving credit for incorrect or inadequate answers, but it does mean allowing candidates to be rewarded for answers showing correct application of principles and knowledge. Examiners should therefore read carefully and consider every response: even if it is not what is expected it may be worthy of credit.

The mark scheme gives examiners:

- an idea of the types of response expected
- how individual marks are to be awarded
- the total mark for each question
- examples of responses that should NOT receive credit.

/ means that the responses are alternatives and either answer should receive full credit.

() means that a phrase/word is not essential for the award of the mark, but helps the examiner to get the sense of the expected answer.

Phrases/words in **bold** indicate that the meaning of the phrase or the actual word is **essential** to the answer.

ecf/TE/cq (error carried forward) means that a wrong answer given in an earlier part of a question is used correctly in answer to a later part of the same question.

Candidates must make their meaning clear to the examiner to gain the mark. Make sure that the answer makes sense. Do not give credit for correct words/phrases which are put together in a meaningless manner. Answers must be in the correct context.

Quality of Written Communication

Questions which involve the writing of continuous prose will expect candidates to:

- write legibly, with accurate use of spelling, grammar and punctuation in order to make the meaning clear
- select and use a form and style of writing appropriate to purpose and to complex subject matter
- organise information clearly and coherently, using specialist vocabulary when appropriate.

Full marks will be awarded if the candidate has demonstrated the above abilities.

Questions where QWC is likely to be particularly important are indicated (QWC) in the mark scheme, but this does not preclude others.

Section A (multiple choice)

Question Number	Answer	Mark
1	<p>1. The only correct answer is D</p> <p><i>A is not correct because BeCl_2 is linear and the bond polarities cancel to make the molecule non-polar</i></p> <p><i>B is not correct because CO_2 is linear and the bond polarities cancel to make the molecule non-polar</i></p> <p><i>C is not correct because CH_4 is tetrahedral and the bond polarities cancel to make the molecule non-polar</i></p>	1

Question Number	Answer	Mark
2	<p>2. The only correct answer is B</p> <p><i>A is not correct because chlorine is oxidised from +1 to +5 and reduced to -1</i></p> <p><i>C is not correct because bromine is oxidised from 0 to +1 and reduced to -1</i></p> <p><i>D is not correct because iodine is oxidised from +1 to +1 and reduced to -1</i></p>	1

Question Number	Answer	Mark
3	<p>3. The only correct answer is C</p> <p><i>A is not correct because the purple layer will be the upper layer</i></p> <p><i>B is not correct because iodine does not produce a black colour in cyclohexane</i></p> <p><i>D is not correct because iodine does not produce a yellow colour in cyclohexane</i></p>	1

Question Number	Answer	Mark
4	<p>4. The only correct answer is C</p> <p><i>A is not correct because there would be no fizzing with dilute nitric acid</i></p> <p><i>B is not correct because there would be no fizzing with dilute nitric acid</i></p> <p><i>D is not correct because there would be no fizzing with dilute nitric acid</i></p>	1

Question Number	Answer	Mark
5	<p>5. The only correct answer is B</p> <p>A is not correct because Group 2 solubility's decrease down the group</p> <p>C is not correct because both hydroxide and sulfate solubility trends are incorrect</p> <p>D is not correct because Group 2 hydroxides decrease up the group</p>	1

Question Number	Answer	Mark
6	<p>6. The only correct answer is A</p> <p>B is not correct because this reaction does not produce effervescence, only a white solid</p> <p>C is not correct because this reaction does not produce effervescence, only some dissolving of the white solid</p> <p>D is not correct because this reaction does not produce effervescence, only the white solid disappears</p>	1

Question Number	Answer	Mark
7	<p>7. The only correct answer is D</p> <p>A is not correct because this will shift the equilibrium to the left and decrease hydrogen production</p> <p>B is not correct because this will shift not affect the equilibrium as there are equal moles each side of the equation and so not affect hydrogen production</p> <p>C is not correct because this will not affect the equilibrium position, merely the rate at which equilibrium reached and so not affect hydrogen production</p>	1

Question Number	Answer	Mark
8(a)	<p>8(a). The only correct answer is B</p> <p>A is not correct because this is all of the molecules present and not just those affected by the catalyst</p> <p>C is not correct because this is only the additional molecules that can react in the presence of a catalyst</p> <p>D is not correct because this is only the additional molecules that can react in the absence of a catalyst</p>	1

Question Number	Answer	Mark
8(b)	<p>8(b). The only correct answer is D</p> <p>A is not correct because peak height decreases and lowering the temperature moves the peak to the left</p> <p>B is not correct because this is the effect of lowering the temperature</p> <p>C is not correct because the height of the peak must decrease to keep the total number of molecules the same</p>	1

Question Number	Answer	Mark
9	<p>9. The only correct answer is D</p> <p>A is not correct because CF_4 only has 42 electrons compared to 62 for CH_3I</p> <p>B is not correct because CHF_2Cl only has 42 electrons compared to 62 for CH_3I</p> <p>C is not correct because CH_2Cl_2 only has 42 electrons compared to 62 for CH_3I</p>	1

Question Number	Answer	Mark
10(a)	<p>10(a). The only correct answer is A</p> <p>B is not correct because magnesium carbonate also decomposes on heating</p> <p>C is not correct because lithium carbonate also decomposes on heating</p> <p>D is not correct because both carbonates decompose on heating</p>	1

Question Number	Answer	Mark
10(b)	<p>10(b). The only correct answer is A</p> <p><i>B is not correct because calcium hydrogencarbonate is soluble</i></p> <p><i>C is not correct because calcium hydroxide is limewater solution</i></p> <p><i>D is not correct because this is not formed by bubbling carbon dioxide through calcium hydroxide solution</i></p>	1

Question Number	Answer	Mark
11(a)	<p>11(a). The only correct answer is C</p> <p><i>A is not correct because oxygen gas is also evolved</i></p> <p><i>B is not correct because brown nitrogen dioxide is also evolved</i></p> <p><i>D is not correct because brown nitrogen dioxide is evolved and colourless oxygen is not inert</i></p>	1

Question Number	Answer	Mark
11(b)	<p>11(b). The only correct answer is B</p> <p><i>A is not correct because the cation is not polarised but polarising</i></p> <p><i>C is not correct because this is a description of polarisation but the cation is the polariser and not polarised</i></p> <p><i>D is not correct because the nitrate electron cloud is attracted by the calcium ion and not repelled</i></p>	1

Question Number	Answer	Mark
12	<p>12. The only correct answer is D</p> <p>A is not correct because the hydrogen bonding in HF results in a much higher boiling temperature than even HI which has the strongest London forces and not the lowest boiling temperature</p> <p>B is not correct because the hydrogen bonding in HF results in a much higher boiling temperature than even HI which has the strongest London forces and not the lowest boiling temperature</p> <p>C is not correct because the hydrogen bonding in HF results in a much higher boiling temperature than even HI which has the strongest London forces and not the lowest boiling temperature</p>	1

Question Number	Answer	Mark
13	<p>13. The only correct answer is C</p> <p>A is not correct because there is no $C_3H_7^+$ fragment produced from $CH_3CBr(CH_3)_2$</p> <p>B is not correct because there is no $C_3H_7^+$ fragment produced from $CH_3CHBrCH_2CH_3$</p> <p>D is not correct because there is no $C_3H_7^+$ fragment produced from $CH_3CHBrCH_2CH_3$</p>	1

Question Number	Answer	Mark
14	<p>14. The only correct answer is B</p> <p>A is not correct because ethanoic acid would produce a fragment $COOH^+$ $m/e=45$</p> <p>C is not correct because ethanol would produce a fragment $C_2H_5O^+$ $m/e=45$</p> <p>D is not correct because if ethanoic acid was present then it would produce a fragment $COOH^+$ $m/e=45$</p>	1

Question Number	Answer	Mark
15	<p>15. The only correct answer is B</p> <p>A is not correct because chlorine free radicals are not absorbed from absorbing infrared radiation</p> <p>C is not correct because the absorption of ultraviolet does not result in a compound being a green house gas</p> <p>D is not correct because <i>i</i></p>	1

Question Number	Answer	Mark
16	<p>16. The only correct answer is D</p> <p>A is not correct because the ratio 2:1 has been used the wrong way round</p> <p>B is not correct because this is the result for the presence of mono-substituted chloroalkane not <i>d</i>-substituted</p> <p>C is not correct because this is adding a factor of two more moles, which give a 1:3 ratio, instead of doubling by two</p>	1

Question Number	Answer	Mark
17	<p>17. The only correct answer is A</p> <p>B is not correct because silver bromide would decompose in sunlight and silver bromide does not dissolve in dilute ammonia</p> <p>C is not correct because silver chloride would also decompose in sunlight</p> <p>D is not correct because both silver halides would decompose in sunlight and only silver chloride would dissolve in dilute ammonia</p>	1

TOTAL FOR SECTION A = 20 MARKS

Section B

Question Number	Acceptable Answers	Reject	Mark
18 (a)	(NH_4^+) $109.5^{(o)}$ / $109^\circ 28'$ ALLOW $109^{(o)}$ (1) (H_3O^+) $107^{(o)}$ (1) ALLOW $106 - 108^{(o)}$ ALLOW The true value of $113^{(o)}$ but with no latitude		2

Question Number	Acceptable Answers	Reject	Mark
18 (b)	BF_3 is trigonal planar ALLOW Triangular planar (1) PH_3 is (triangular/trigonal) pyramidal (1) PH_3 has a lone pair of electrons (1) and four areas of electron repulsion (not three) OR BF_3 has three areas of electron repulsion (not four) (1)		4

Question Number	Acceptable Answers	Reject	Mark
18 (c)	Graphite has delocalised electrons but diamond does not have delocalised electrons (1) In graphite each carbon atom forms 3 covalent bonds and one electron delocalised (1) All the electrons in diamond are involved in bonding/all the electrons in diamond are localised in bonding/each carbon atom forms 4 covalent bonds (1) Delocalised electrons can move (and carry charge hence the greater conductivity in graphite) (1)		4

Question Number	Acceptable Answers	Reject	Mark
18 (d)	<p>Iodine has more shells of electrons/has a larger atomic radius (1)</p> <p>therefore Iodine has greater shielding (of its nuclear charge) (1)</p> <p>there is less attraction between the nucleus and the bonding pair of electrons (even though iodine has more protons) (1)</p> <p>ALLOW reverse argument for chlorine</p> <p>IGNORE References to electronegativity</p>	Ionic radius Iodine molecules	3

(Total for Question 18 = 13 MARKS)

Question Number	Acceptable Answers	Reject	Mark
19 (a)(i)	(skeletal formula)  IGNORE Bond lengths, bond angles and orientation Bond to the H of the OH (1) (Name) 3-methylbutan-2-ol IGNORE punctuation (1) (Classification) (3-methylbutan-1-ol) Primary and (2-methylbutan-2-ol) Tertiary (1)		3

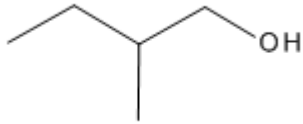
Question Number	Acceptable Answers	Reject	Mark
19 (a)(ii)	Either 2-methylbutan-1-ol OR  OR displayed /structural formula If name and formula are given then both must be correct		1

Question Number	Acceptable Answers	Reject	Mark
19 (a)(iii)	<p>2,2-dimethylpropan-1-ol has weaker London forces/van der Waals' forces/instantaneous dipole induced dipole forces/dispersion forces IGNORE Reference to intermolecular forces (1)</p> <p>Because the branching reduces the surface area (contact possible between the molecules)</p> <p>ALLOW Molecules are unable to arrange themselves as closely together/pack less well Suitable labelled diagram (1)</p> <p>Ignore references to –OH group/hydrogen bonding ALLOW reverse arguments for pentan-1-ol</p>	Different numbers of electrons	2

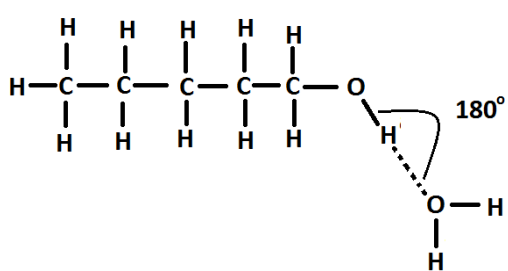
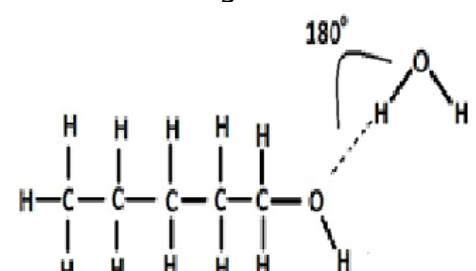
Question Number	Acceptable Answers	Reject	Mark
19 (a)(iv)	<p>Diagram such as</p>  <p>Linear O—HO hydrogen bond (1)</p> <p>180° with clear label (1)</p> <p>IGNORE presence or absence of dipoles and lone pairs</p> <p>Alternative diagram</p>  <p>If two hydrogen bonds are drawn then both must be correct IGNORE length of hydrogen bond</p> <p>ALLOW (1) if a hydrogen bond is drawn correctly between two pentan-1-ol molecules</p>	Label to the H or O atoms	2

Question Number	Acceptable Answers	Reject	Mark
19 (b)(i)	(Oxidizing agent) $\text{Na}_2\text{Cr}_2\text{O}_7$ / $\text{K}_2\text{Cr}_2\text{O}_7$ ALLOW $\text{Cr}_2\text{O}_7^{2-}$ IGNORE name of oxidizing agent, even if incorrect (1) (Conditions) Acidic/acidified/sulfuric acid / H^+ and reflux/heat ALLOW Acidified on the line for oxidizing agent IGNORE References to acid concentration (1) Second mark dependant on an oxidizing agent	HCl/ Hydrochloric acid/ Heat in a closed system	2

Question Number	Acceptable Answers	Reject	Mark
19 (b)(ii)	$\text{C}_2\text{H}_5\text{OH} + 2[\text{O}] \rightarrow \text{CH}_3\text{COOH} + \text{H}_2\text{O}$ OR Multiples ALLOW Structural / display /skeletal IGNORE state symbols even if incorrect	Molecular formulae O_2	1

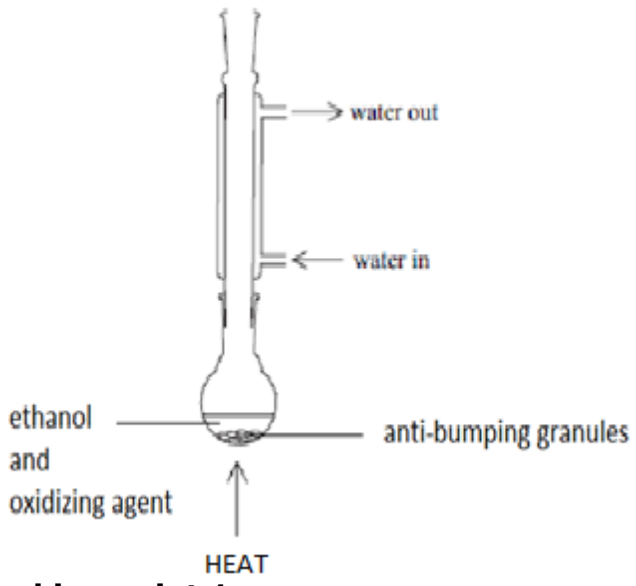
Question Number	Acceptable Answers	Reject	Mark
<p>19 (b)(iii)</p>	<p>Any suitable diagram of reflux, e.g.</p>  <p>Marking point 1 Vertical condenser with water in/out shown correctly (1)</p> <p>Marking point 2 suitable flask containing reagents and heat/electrical heater COMMENT Allow water bath Flask should have some contents shown (1)</p> <p>Marking point 3 Anti-bumping granules (1)</p> <p>Diagrams of distillation can score MP2 and MP3 only</p>	<p>Thermometer/ Sealed apparatus / gaps between apparatus</p> <p>Conical flask</p>	<p>3</p>

Question Number	Acceptable Answers	Reject	Mark
19 (c)(i)	<p>Trial titre is less than the mean titre/is an undershoot (1)</p> <p>An air bubble in the pipette so less than 25.00 cm³ of acid tested OR Pipette only washed with (deionised) water and not the acid/pipette contained water from washing ALLOW Pipette tip not touched on the solution to remove the full volume of acid</p> <p>IGNORE Reference to some acid left in the pipette Pipette not washed properly (1)</p>	Not filled to the mark	2

Question Number	Acceptable Answers	Reject	Mark
19 (c)(ii)	<p>$n = (0.0145 \times 0.2 =) 2.90 \times 10^{-3} / 0.00290$ (1)</p> <p>$c = (2.90 \times 10^{-3} \div 0.025 =) 0.116 \text{ (mol dm}^{-3}\text{)}$ (1)</p> <p>IGNORE SF except 1SF</p>		2

Question Number	Acceptable Answers	Reject	Mark
19 (c)(iii)	<p>Method 1 $n = (0.116 \div 2 =) 0.058$ or $n = (0.0029 \times (500 \div 25) =) 0.058$ (1)</p> <p>$m = (0.058 \times 60 =) 3.48 \text{ (g)}$ (1)</p> <p>OR Method 2 $m = (0.00290 \times 60 =) 0.174 \text{ (g in 25 cm}^3\text{)}$ (1)</p> <p>$m = (0.174 \times 25 =) 4.35 \text{ (g in 250 cm}^3\text{)}$ (1)</p> <p>IGNORE SF except 1SF</p>		2

Question Number	Acceptable Answers	Reject	Mark
19 (d)(i)	<p>$\text{C}_6\text{H}_{13}\text{OH} + 9\text{O}_2 \rightarrow 6\text{CO}_2 + 7\text{H}_2\text{O}$ ALLOW Multiples Ignore state symbols even if incorrect</p>		1

Question Number	Acceptable Answers	Reject	Mark
19 (d)(ii)	$C_6H_{13}OH + 3O_2 \rightarrow 6C + 7H_2O$ ALLOW Multiples IGNORE state symbols even if incorrect		1

Question Number	Acceptable Answers	Reject	Mark
19 (d)(iii)	<p>Volume = (9 x 24 =) 216 (dm³) (1)</p> <p>COMMENT Not clipped so allow 9½ x 24 = 228 (dm³)</p> <p>(Observation) Black smoke/black soot</p> <p>ALLOW just 'soot' / black carbon</p> <p>Ignore just 'carbon' (1)</p> <p>(justification) Only 100 dm³ of oxygen (20% of 500) is present</p> <p>Ignore just 'there is insufficient oxygen' (1)</p>		3

Total for Question 19 = 25 MARKS
TOTAL FOR SECTION B = 38 MARKS

Section C

Question Number	Acceptable Answers	Reject	Mark
20 (a)	SrCO ₃ (1)	CaCO ₃ Sr ²⁺	2
	Li ₂ CO ₃ (1) Penalise use of names rather than formulae once only	Rb ₂ CO ₃ Li ⁺	

Question Number	Acceptable Answers	Reject	Mark
20 (b)	Heat (from the exploding firework) excites/promotes electrons to a higher energy level (1)		3
	These electrons return to the ground state (1)		
	Energy is released in the visible part of the spectrum (1)		

Question Number	Acceptable Answers	Reject	Mark
20 (c)	(Metal) magnesium/Mg/ Aluminium/Al/ Titanium/Ti (1)	Beryllium	2
	(Compound) Magnesium oxide/MgO/ Aluminium oxide/Al ₂ O ₃ /Titanium oxide/TiO ₂ ALLOW Magnesium nitride/ Mg ₃ N ₂ (1)	Magnesium carbonate	

Question Number	Acceptable Answers	Reject	Mark
20 (d)(i)	2KNO ₃ + (1)S + 3C → (1)K ₂ S + (1)N ₂ + 3CO ₂		2
	Product of CO ₂ (1)		
	Balancing (1) ALLOW multiples		

Question Number	Acceptable Answers	Reject	Mark
20 (d)(ii)	<p>Nitrogen and sulfur/ N and S (are reduced) (1)</p> <p>(Nitrogen/N) goes from (+)5 to 0 (1)</p> <p>(Sulfur/S) goes from 0 to -2 (1)</p> <p>ALLOW Nitrogen and sulfur in any order</p> <p>IGNORE Carbon going from 0 to +4</p>	N ₂ S ₈	3

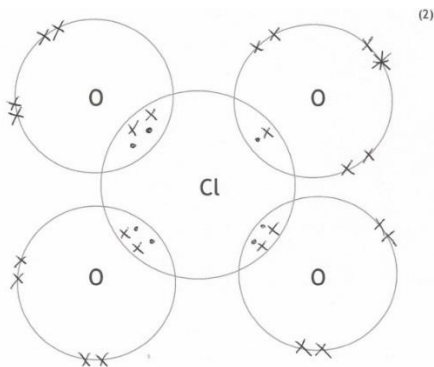
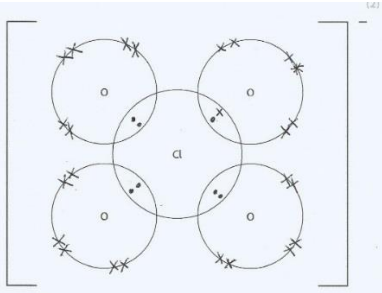
Question Number	Acceptable Answers	Reject	Mark
20 (e)(i)	<p>Example diagram such as</p>  <p>Correct dots and crosses on three oxygens for the double bonds to the chlorine (1)</p> <p>Correct dots, crosses and asterisk on the fourth oxygen ALLOW The asterisk electron to be anywhere on the fourth oxygen (1)</p> <p>ALLOW Three dative bonds from the chlorine and one covalent bond.</p>  <p>ALLOW Any combination of dative and double bonds to the oxygen that result in an appropriate number of electrons in the outer shell of each respective atom</p>		2

Question Number	Acceptable Answers	Reject	Mark
20 (e)(ii)	<p>(potassium) chlorate(VII) may reach/enter groundwater sources / end up in drinking water (1)</p> <p>And it is toxic/poisonous</p> <p>IGNORE</p> <p>References to acidity (1)</p> <p>ALLOW</p> <p>Chlorine compounds may reach the ozone layer</p> <p>OR</p> <p>Free radicals/Cl[•]/ClO[•] (1)</p> <p>And result in ozone depletion/ free radicals/Cl[•]/ClO[•] result in ozone depletion (1)</p> <p>OR</p> <p>Ozone may be formed in the (lower) atmosphere (1)</p> <p>Which is toxic (1)</p>	<p>Toxic gases such as HCl/ Cl₂</p> <p>Greenhouse Effect</p>	2

Question Number	Acceptable Answers	Reject	Mark
20 (f)	<p>The fuse burns releasing energy/reacts exothermically (1)</p> <p>Which provides the activation energy (1)</p> <p>It is used up in the reaction</p> <p>OR</p> <p>It does not lower the activation energy</p> <p>OR</p> <p>It does not provide an alternative reaction pathway (and so is not a catalyst) (1)</p>		3

Question Number	Acceptable Answers	Reject	Mark
20 (g)	<p>Reference to two suitable factors from surface area, temperature, concentration (1)</p> <p>Any two from (Surface area) – increase will increase reaction rate because more particle-particle contact for reaction (1)</p> <p>(Temperature) – more exothermic/more heat given off will increase reaction rate because particles will have more kinetic energy for reaction (1)</p> <p>(Concentration) – more tightly-packed will increase reaction rate because more particle-particle contact for reaction (1)</p> <p>ALLOW Reverse arguments to slow the reaction down</p>		3

TOTAL FOR SECTION C (Question 20) = 22 MARKS

TOTAL FOR PAPER = 80 MARKS

Further copies of this publication are available from
Edexcel Publications, Adamsway, Mansfield, Notts, NG18 4FN

Telephone 01623 467467

Fax 01623 450481

Email publication.orders@edexcel.com

Order Code

For more information on Edexcel qualifications, please visit our website
www.edexcel.com

Pearson Education Limited. Registered company number 872828
with its registered office at 80 Strand, London, WC2R 0RL, United Kingdom



Llywodraeth Cynulliad Cymru
Welsh Assembly Government

