



**Cambridge International Examinations**  
Cambridge Ordinary Level

CANDIDATE  
NAME

CENTRE  
NUMBER

--	--	--	--	--

CANDIDATE  
NUMBER

--	--	--	--



**CHEMISTRY**

**5070/42**

Paper 4 Alternative to Practical

**October/November 2016**

**1 hour**

Candidates answer on the Question Paper.

No Additional Materials are required.

**READ THESE INSTRUCTIONS FIRST**

Write your Centre number, candidate number and name on all the work you hand in.

Write in dark blue or black pen.

You may use an HB pencil for any diagrams or graphs.

Do not use staples, paper clips, glue or correction fluid.

**DO NOT WRITE IN ANY BARCODES.**

Answer **all** questions.

Write your answers in the spaces provided in the Question Paper.

Electronic calculators may be used.

At the end of the examination, fasten all your work securely together.

The number of marks is given in brackets [ ] at the end of each question or part question.

This document consists of **16** printed pages.

- 1 A student uses acidified aqueous potassium manganate(VII) to oxidise ethanol to ethanoic acid.

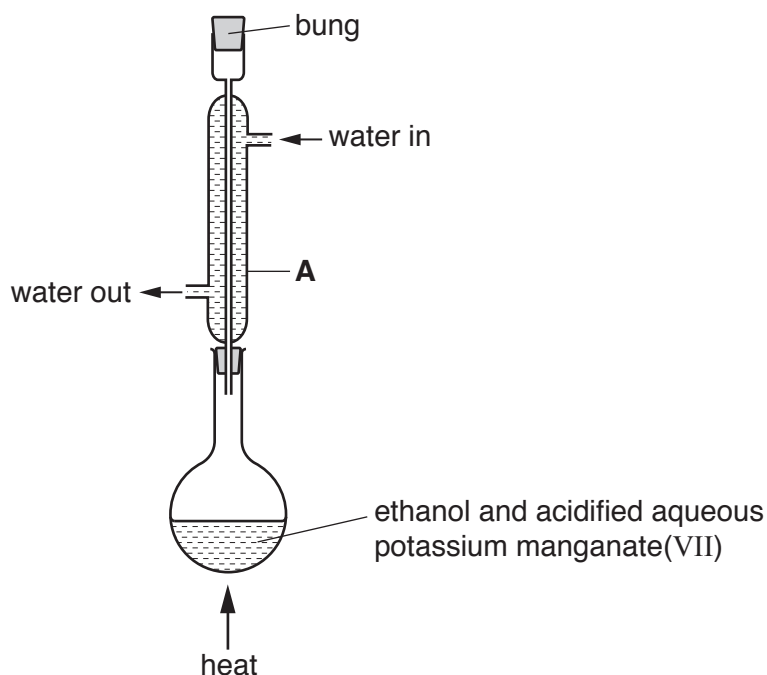

- (a) (i) Name apparatus **A**.

..... [1]

- (ii) What is the purpose of apparatus **A**?

..... [1]

- (b) Identify **two** errors in the student's apparatus.

1. ....

2. ....

[2]

The errors are corrected before the student begins heating.

- (c) (i) State why a Bunsen burner should not be used to heat the mixture of ethanol and potassium manganate(VII).

..... [1]

- (ii) What should be used instead of a Bunsen burner?

..... [1]

(d) Name the process that the student uses to separate ethanoic acid from the mixture after heating.

..... [1]

(e) The ethanoic acid is heated with another sample of ethanol and a catalyst of sulfuric acid.

Name the organic product.

..... [1]

[Total: 8]

2 The apparatus shown is used to electrolyse dilute sulfuric acid.

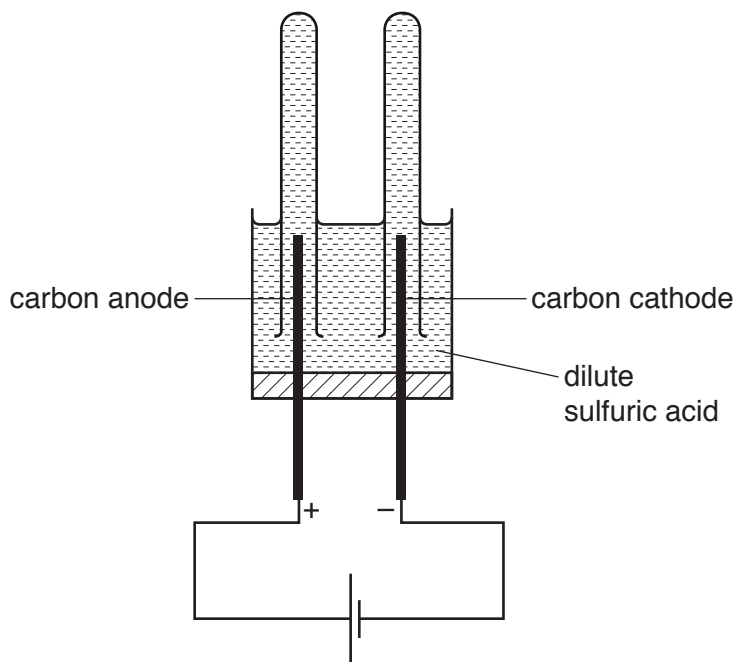

(a) Name the gas that collects at the anode. Give a test and observation to identify this gas.

name of gas .....

test and observation .....

[2]

(b) Name the gas that collects at the cathode. Give a test and observation to identify this gas.

name of gas .....

test and observation .....

[2]

- (c) The student does three more experiments with different electrolytes, using the apparatus shown.

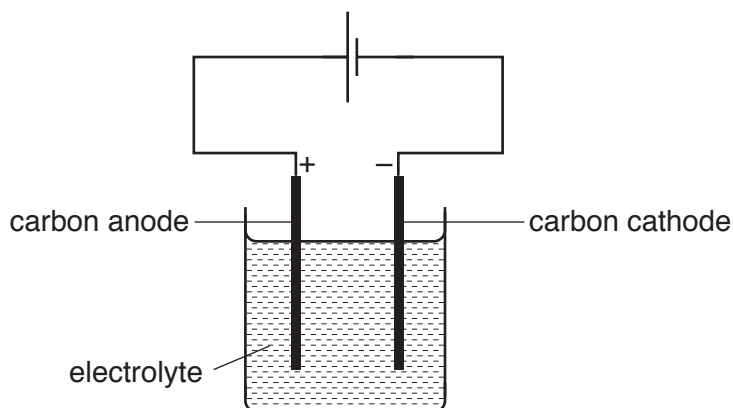

Complete the table.

electrolyte	name of product at the anode	observations at the anode	name of product at the cathode	observations at the cathode
concentrated aqueous sodium iodide		black solid / brown solution		bubbles of colourless gas
concentrated aqueous copper(II) sulfate		bubbles of colourless gas		pink solid
concentrated aqueous sodium chloride	chlorine		hydrogen	

[6]

[Total: 10]

In questions 3 to 6 inclusive, place a tick (✓) in the box against the correct answer.

- 3 A student burns 4.8 g of an element **X** in excess oxygen. The mass of the oxide produced is 8.0 g.

What is the empirical formula of the oxide of **X**?

[ $A_r$ : **X**, 24; O, 16]

(a) **XO**

(b) **X<sub>2</sub>O**

(c) **X<sub>2</sub>O<sub>2</sub>**

(d) **X<sub>3</sub>O<sub>5</sub>**

[Total: 1]

- 4 The chromatogram shows the results of chromatography using mixture **Z** as well as individual dyes labelled 1, 2, 3 and 4.

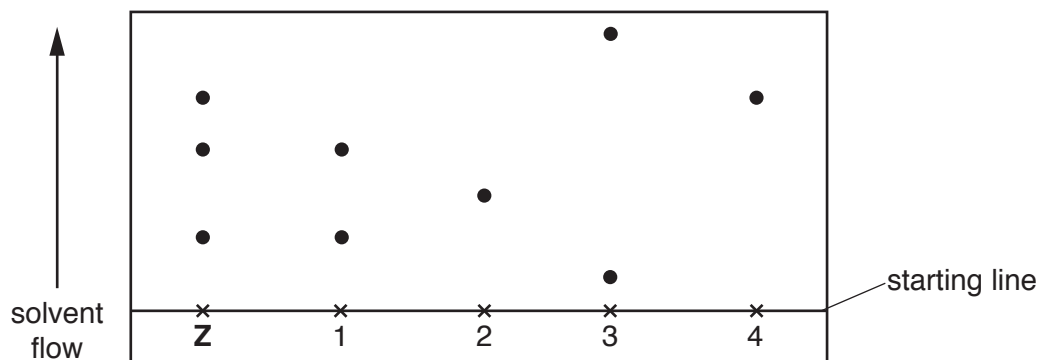

Which of the dyes does **Z** contain?

(a) 1 only

(b) 2 and 3

(c) 1 and 4

(d) 4 only

[Total: 1]

- 5 A student adds excess zinc to hydrochloric acid and measures the volume of hydrogen gas given off at regular time intervals. This is experiment 1.

The student makes a change to **one** of the conditions and then repeats the experiment. This is experiment 2.

The volume of hydrochloric acid is the same in both experiments.

Graphs for both experiments 1 and 2 are shown.

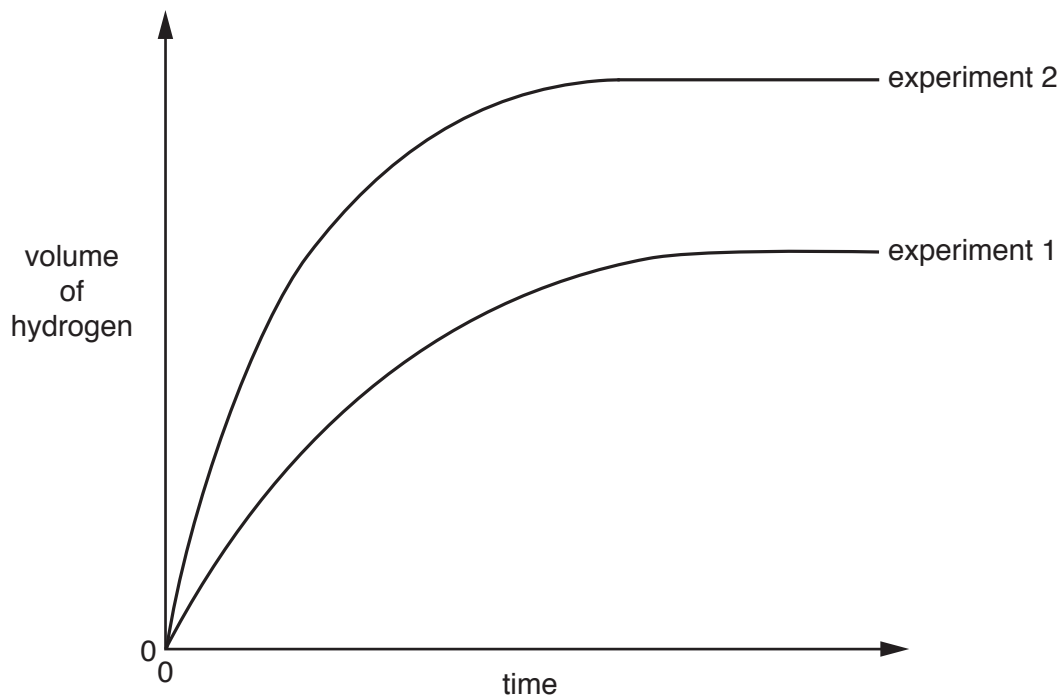

What is the different condition used in experiment 2?

- (a) A catalyst is added.
- (b) A higher temperature is used.
- (c) A greater mass of zinc is used.
- (d) A higher concentration of hydrochloric acid is used.

[Total: 1]

- 6 A student passes air backwards and forwards over heated copper using the apparatus shown. The original volume of air in the apparatus is  $50.0\text{ cm}^3$ .

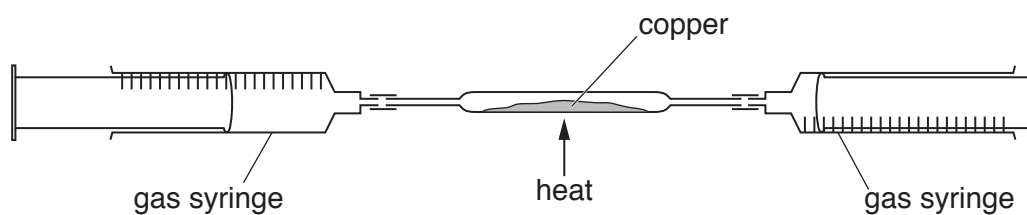

The experiment continues until the volume of gas stops changing. Some unreacted copper remains.

What is the final volume of gas in the apparatus?

[All volumes are measured at room temperature and pressure.]

- (a)  $10\text{ cm}^3$
- (b)  $30\text{ cm}^3$
- (c)  $40\text{ cm}^3$
- (d)  $60\text{ cm}^3$

[Total: 1]



- 7 Vinegar contains dilute ethanoic acid. Different brands of vinegar contain different concentrations of ethanoic acid.

You are provided with two different brands of colourless vinegar as well as the apparatus and chemicals normally found in a laboratory.

Describe how you would carry out experiments to find out which of the two brands contains the higher concentration of ethanoic acid.

You should give experimental details and the observations occurring at each stage of the procedure.

.....

.....

.....

.....

.....

.....

.....

.....

.....

.....

.....

[Total: 5]

- 8 A student does an experiment to determine the percentage by mass of copper in a sample of impure copper. The sample of impure copper is placed in a previously weighed container and reweighed.

$$\text{mass of container + impure copper} = 7.45 \text{ g}$$

$$\text{mass of empty container} = 5.72 \text{ g}$$

- (a) Calculate the mass of impure copper used in the experiment.

..... g [1]

The student transfers the sample of impure copper to a beaker, adds excess concentrated nitric acid and stirs until all the solid has dissolved. The copper reacts with the nitric acid producing aqueous copper nitrate as shown in **equation 1**.

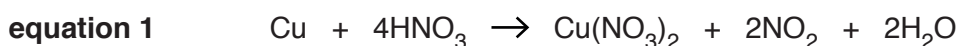

An excess of aqueous potassium iodide and an excess of dilute hydrochloric acid are then added to the beaker. A further reaction occurs as shown in **equation 2**.



The contents of the beaker are transferred to a suitable container and made up to  $250 \text{ cm}^3$  with distilled water. This is solution **J**.

- (b) Name the container in which solution **J** should be made.

..... [1]

The student transfers  $25.0 \text{ cm}^3$  of **J** to a conical flask and adds a few drops of a suitable indicator.

An aqueous solution of  $0.100 \text{ mol/dm}^3$  sodium thiosulfate,  $\text{Na}_2\text{S}_2\text{O}_3$ , is put into a burette and run into the conical flask until the end-point is reached. The reaction between sodium thiosulfate,  $\text{Na}_2\text{S}_2\text{O}_3$ , and iodine,  $\text{I}_2$ , is shown in **equation 3**.

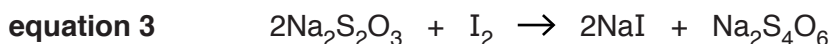

- (c) Three titrations are done. The diagrams show parts of the burette with the liquid levels at the beginning and end of each titration.

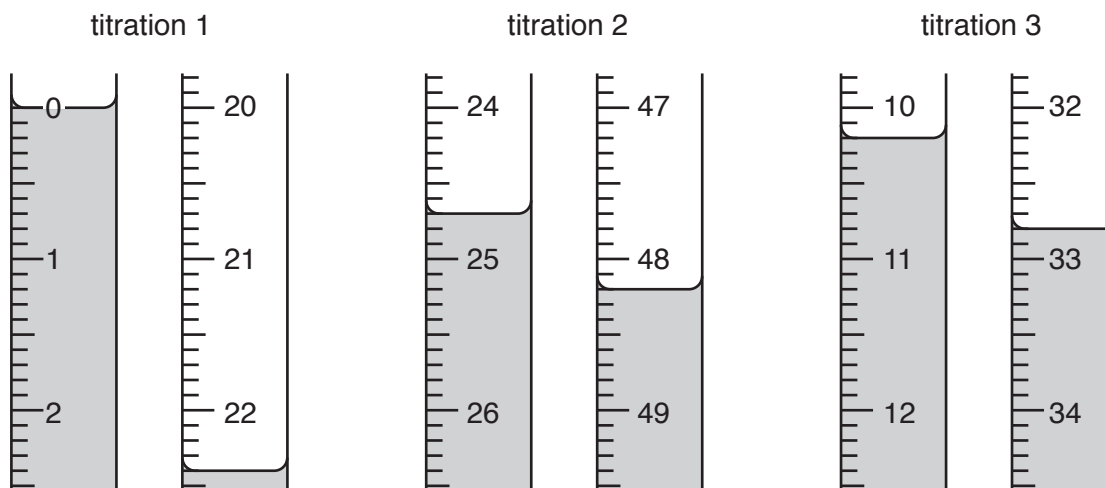

Use the diagrams to complete the results table.

titration number	1	2	3
final burette reading/cm <sup>3</sup>			
initial burette reading/cm <sup>3</sup>			
volume of 0.100 mol/dm <sup>3</sup> Na <sub>2</sub> S <sub>2</sub> O <sub>3</sub> /cm <sup>3</sup>			
best titration results (✓)			

### Summary

Tick (✓) the best titration results.

Using these results, the average volume of 0.100 mol/dm<sup>3</sup> Na<sub>2</sub>S<sub>2</sub>O<sub>3</sub> is

..... cm<sup>3</sup>.  
[4]

(d) Calculate the number of moles of Na<sub>2</sub>S<sub>2</sub>O<sub>3</sub> in the average volume of 0.100 mol/dm<sup>3</sup> Na<sub>2</sub>S<sub>2</sub>O<sub>3</sub>.

..... moles [1]

(e) Use your answer to (d) and **equation 3** to calculate the number of moles of I<sub>2</sub> in 25.0 cm<sup>3</sup> of J.

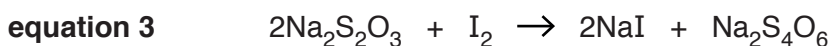

..... moles [1]

(f) Use your answer to (e) to calculate the number of moles of I<sub>2</sub> in 250 cm<sup>3</sup> of J.

..... moles [1]

- (g) Use your answer to (f) and **equation 2** to calculate the number of moles of  $\text{Cu}(\text{NO}_3)_2$  that produce the number of moles of  $\text{I}_2$  calculated in (f).

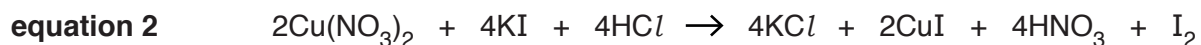

..... moles [1]

- (h) Use your answer to (g) and **equation 1** to deduce the number of moles of Cu that produce the number of moles of  $\text{Cu}(\text{NO}_3)_2$  calculated in (g).

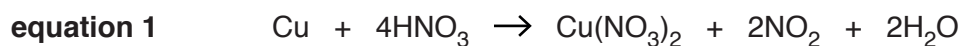

..... moles [1]

- (i) Use your answer to (h) to calculate the mass of copper in the sample of impure copper.

[ $A_r$ : Cu, 63.5]

..... g [1]

- (j) Use your answers to (i) and (a) to calculate the percentage by mass of copper in the sample of impure copper.

.....% [1]

[Total: 13]

- 9 The following table shows the tests a student does on a mixture **L**, which contains two compounds.

**L** contains three different ions.

Complete the table by adding the conclusion for **(a)**, the observations for **(b) (i)**, **(ii)** and **(iii)**, the conclusions for tests **(c) (i)** and **(ii)**, and both the test and observation which lead to the conclusion for test **(d)**. Any gases produced should be identified by test, result and name.

test	observation	conclusion	
<b>(a)</b> <b>L</b> is dissolved in water and the solution divided into three parts for tests <b>(b)</b> , <b>(c)</b> and <b>(d)</b> .	A colourless solution is formed.		[1]
<b>(b) (i)</b> To the first part, aqueous sodium hydroxide is added until a change is seen.  <b>(ii)</b> An excess of aqueous sodium hydroxide is added to the mixture from <b>(i)</b> .  <b>(iii)</b> This mixture is then heated.		<b>L</b> contains $Al^{3+}$ , $Zn^{2+}$ or $Ca^{2+}$ ions.  <b>L</b> contains $Al^{3+}$ or $Zn^{2+}$ ions.  <b>L</b> contains $NH_4^+$ ions.	[4]
<b>(c) (i)</b> To the second part, aqueous ammonia is added until a change is seen.  <b>(ii)</b> An excess of aqueous ammonia is added to the mixture from <b>(i)</b> .	A white precipitate forms.  The precipitate is insoluble in excess.		[1]
<b>(d)</b>		<b>L</b> contains $SO_4^{2-}$ ions.	[3]

- (e)** Give the formulae of the two compounds which are present in mixture **L**.

..... and ..... [2]

[Total: 11]

10 When metal **M** is added to aqueous copper(II) sulfate the temperature rises.

(a) What type of reaction does the temperature rise indicate?

..... [1]

The equation for the reaction is shown.

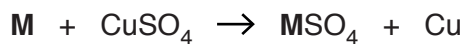

A student transfers  $25.0\text{cm}^3$  of  $2.7\text{mol/dm}^3$  of aqueous copper(II) sulfate to a glass beaker. A  $0.4\text{g}$  sample of metal **M** is added to the beaker and the mixture is stirred. The student records the maximum temperature rise with a thermometer.

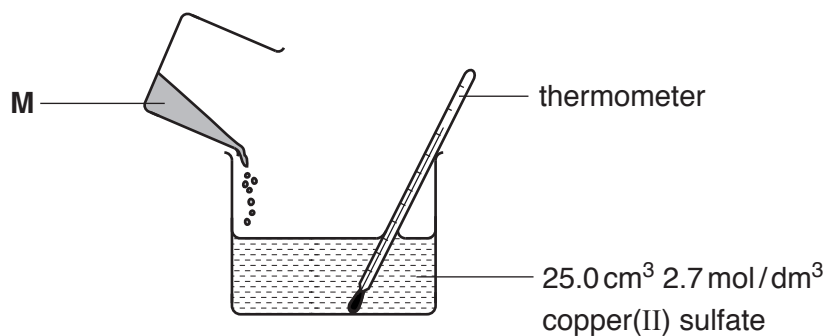

The student repeats the experiment using different masses of metal **M** and in each case calculates and records the maximum temperature rise.

mass of <b>M</b> /g	maximum temperature rise/°C
0.4	2.2
0.8	4.4
1.2	6.6
1.6	8.8
2.0	8.8
2.4	8.8

- (b) Plot the maximum temperature rise against the mass of **M** on the grid and draw two intersecting straight lines through the points.

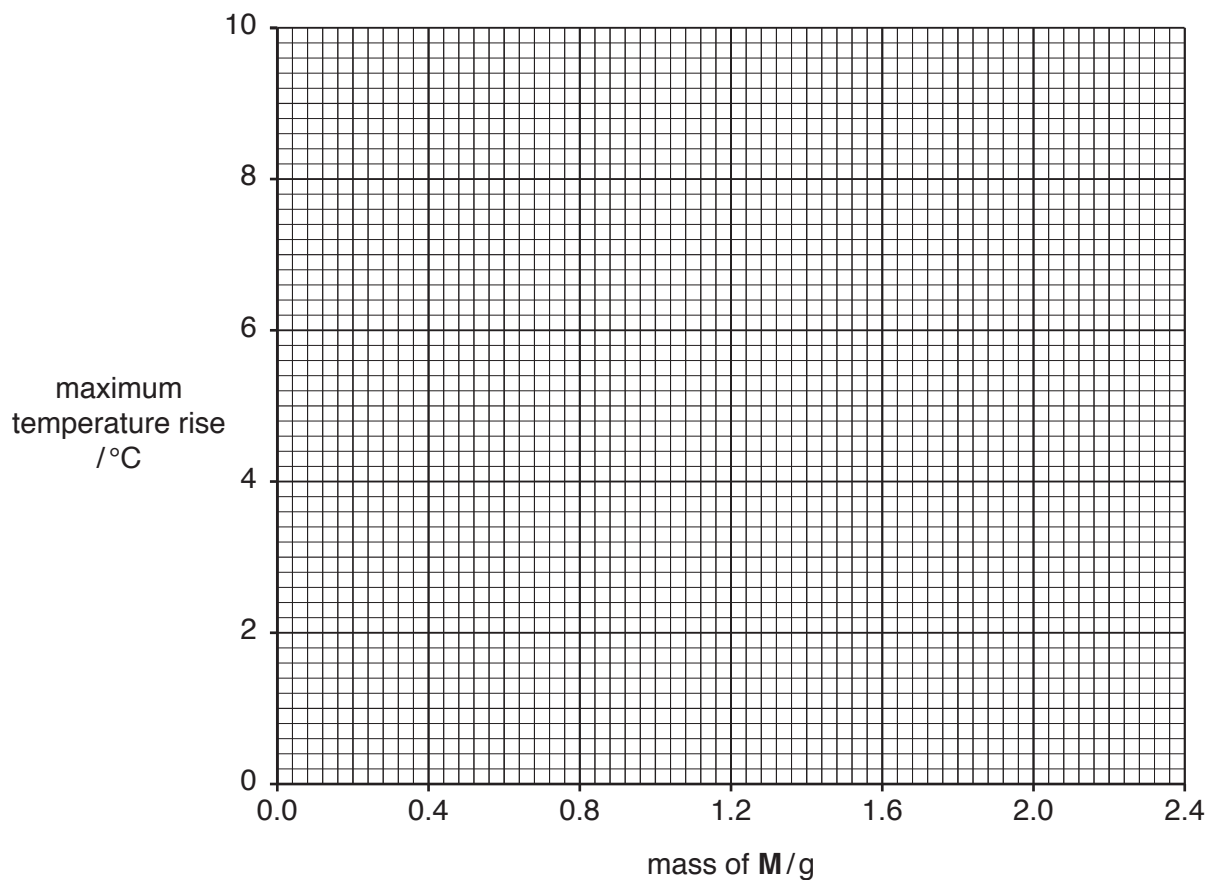

[3]

- (c) (i) Use your graph to determine the mass of **M** required to produce a maximum temperature rise of 5.0 °C.

..... g [1]

- (ii) Use your graph to determine the maximum temperature rise which would occur if 1.5 g of **M** is used in the experiment.

..... °C [1]

- (d) (i) Calculate the number of moles of copper(II) sulfate in 25.0 cm<sup>3</sup> of 2.7 mol/dm<sup>3</sup> aqueous copper(II) sulfate.

..... moles [1]

- (ii) Use your graph to deduce the mass of **M** that reacts completely with 25.0 cm<sup>3</sup> of 2.7 mol/dm<sup>3</sup> aqueous copper(II) sulfate.

..... g [1]

(iii) Use the equation

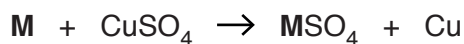

and your answers to (d)(i) and (d)(ii) to calculate the relative atomic mass of metal **M**.

..... [1]

[Total: 9]

---

Permission to reproduce items where third-party owned material protected by copyright is included has been sought and cleared where possible. Every reasonable effort has been made by the publisher (UCLES) to trace copyright holders, but if any items requiring clearance have unwittingly been included, the publisher will be pleased to make amends at the earliest possible opportunity.

To avoid the issue of disclosure of answer-related information to candidates, all copyright acknowledgements are reproduced online in the Cambridge International Examinations Copyright Acknowledgements Booklet. This is produced for each series of examinations and is freely available to download at [www.cie.org.uk](http://www.cie.org.uk) after the live examination series.

Cambridge International Examinations is part of the Cambridge Assessment Group. Cambridge Assessment is the brand name of University of Cambridge Local Examinations Syndicate (UCLES), which is itself a department of the University of Cambridge.