



UNIVERSITY OF CAMBRIDGE INTERNATIONAL EXAMINATIONS
General Certificate of Education Ordinary Level

CHEMISTRY

5070/11

Paper 1 Multiple Choice

October/November 2013

1 hour

Additional Materials: Multiple Choice Answer Sheet
 Soft clean eraser
 Soft pencil (type B or HB recommended)



READ THESE INSTRUCTIONS FIRST

Write in soft pencil.

Do not use staples, paper clips, highlighters, glue or correction fluid.

Write your name, Centre number and candidate number on the Answer Sheet in the spaces provided unless this has been done for you.

DO NOT WRITE IN ANY BARCODES.

There are **forty** questions on this paper. Answer **all** questions. For each question there are four possible answers **A, B, C** and **D**.

Choose the **one** you consider correct and record your choice in **soft pencil** on the separate Answer Sheet.

Read the instructions on the Answer Sheet very carefully.

Each correct answer will score one mark. A mark will not be deducted for a wrong answer.

Any rough working should be done in this booklet.

A copy of the Periodic Table is printed on page 16.

Electronic calculators may be used.

This document consists of **16** printed pages.



1 Which process provides the best evidence for the particle theory of matter?

- A dehydration
- B diffusion
- C filtration
- D neutralisation

2 The results of two tests on a solution **X** are shown.

reagent added	few drops	an excess
aqueous sodium hydroxide	white precipitate	precipitate dissolves
aqueous ammonia	white precipitate	precipitate remains

Which ion is present in solution **X**?

- A Al^{3+}
- B Ca^{2+}
- C Cu^{2+}
- D Zn^{2+}

3 A student wanted to follow how the rate of the reaction of sodium sulfite with acid varies with time. The reaction produces gaseous sulfur dioxide.

Which apparatus is **not** suitable?

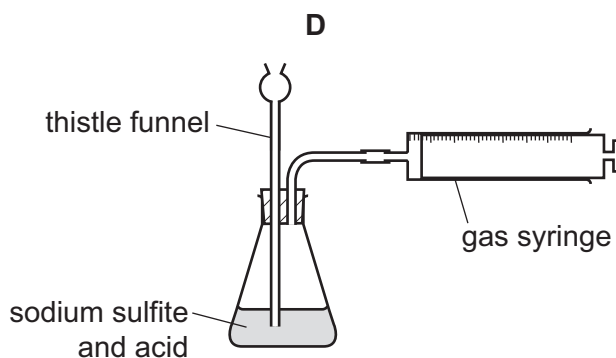
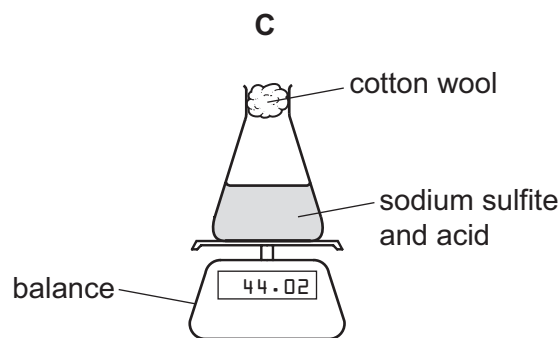
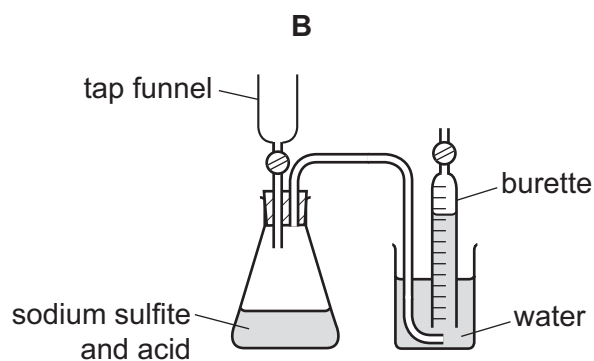
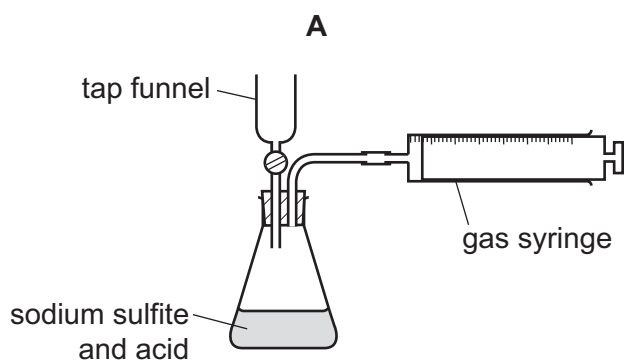

- 4 The apparatus shown is used to distil a dilute solution of ethanol in water.
[B.P.: ethanol, 78 °C; water 100 °C]

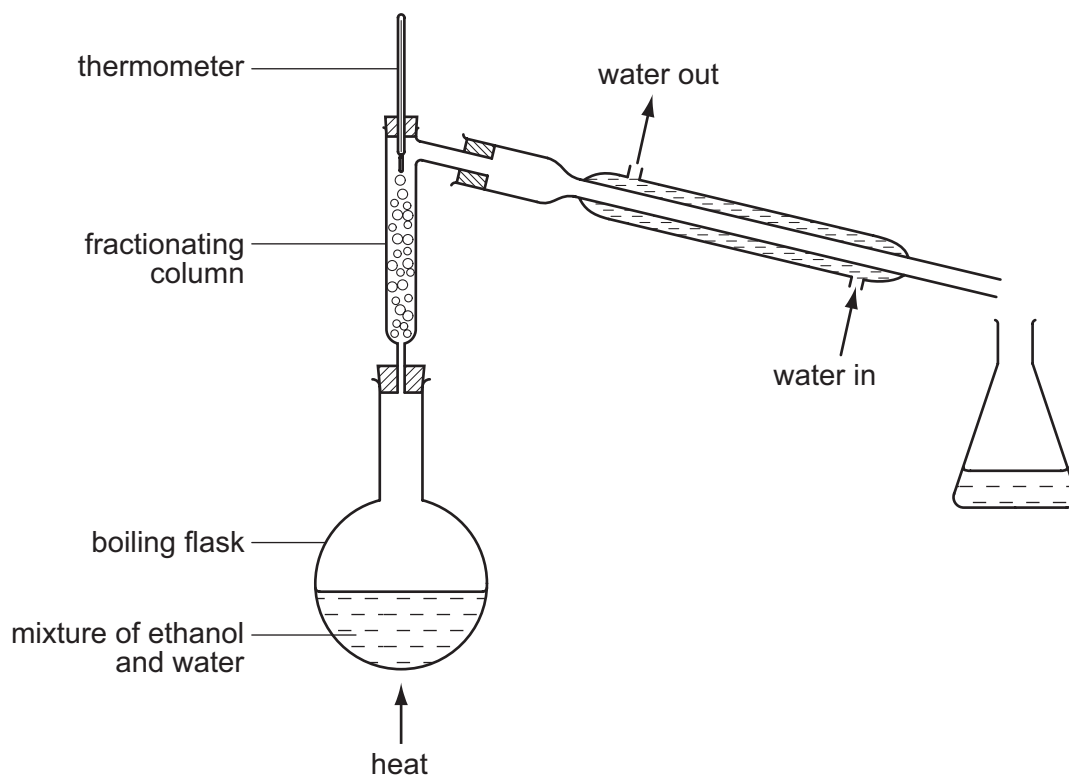

Which graph shows the change in concentration of the ethanol in the boiling flask as the distillation proceeds?

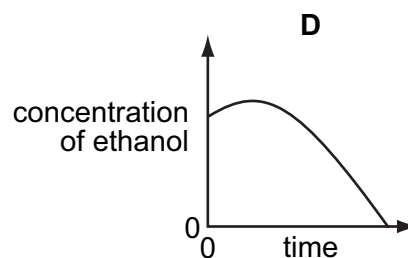
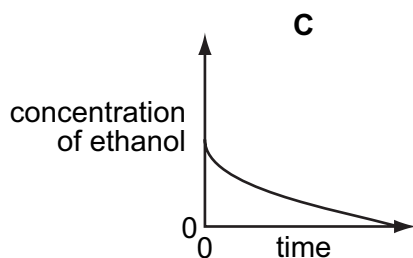
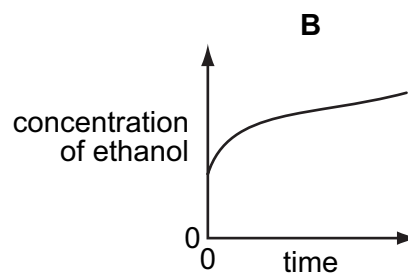
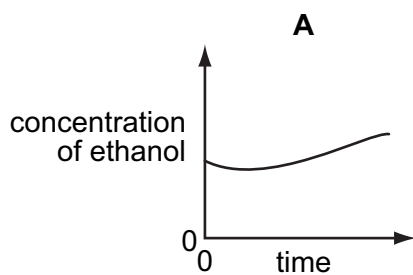

- 5 Aqueous silver nitrate is added to separate solutions of potassium chloride and sodium iodide.

What are the colours of the precipitates formed?

	colour of precipitate formed with chloride	colour of precipitate formed with iodide
A	white	white
B	white	yellow
C	yellow	white
D	yellow	yellow

- 6 Which substance will **not** conduct electricity at room temperature and pressure?

- A** dilute nitric acid
- B** graphite
- C** mercury
- D** sodium chloride

- 7 Which diagram correctly shows the arrangement of the ions in solid sodium chloride?

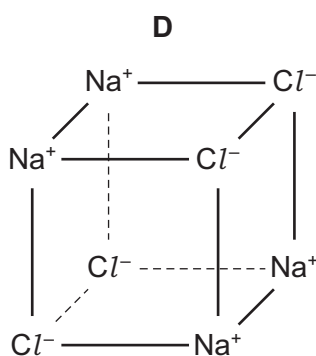
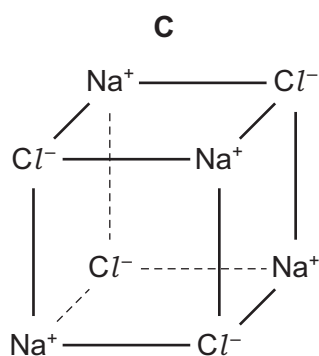
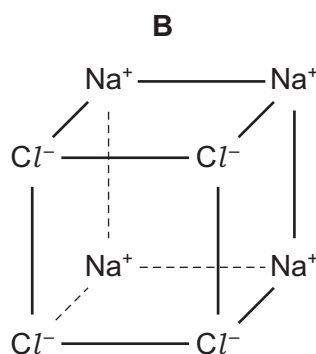
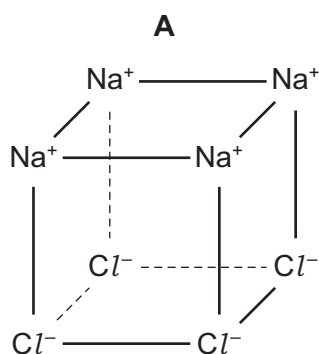

- 8 The diagram shows the electrolysis of aqueous sodium chloride and of molten sodium chloride.

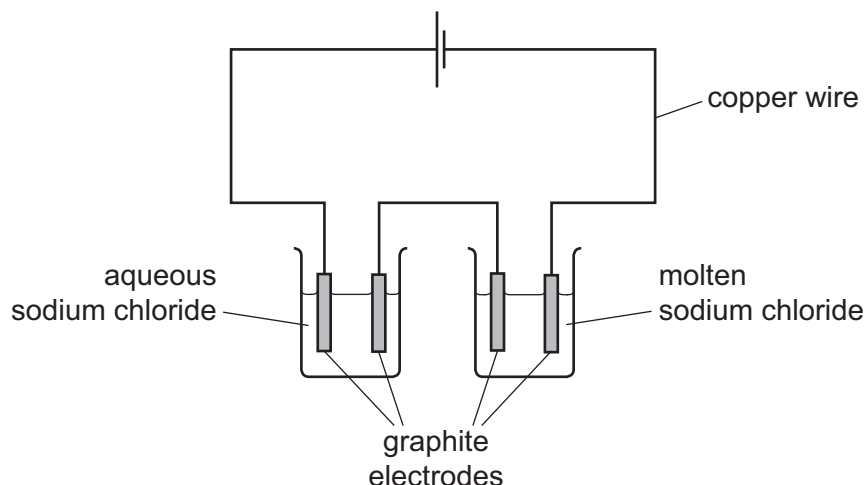

Which substance in the diagram has both positive ions and mobile electrons?

- A aqueous sodium chloride
 - B copper wire
 - C graphite electrodes
 - D molten sodium chloride
- 9 Which statement describes the conversion of magnesium atoms to magnesium ions?
- A The change is reduction, because there has been a gain of electrons.
 - B The change is oxidation, because there has been a loss of electrons.
 - C The change is reduction, because there has been a loss of electrons.
 - D The change is oxidation, because there has been a gain of electrons.

- 10 The diagram shows the structural formula of the covalent molecule hydrazine, N_2H_4 .

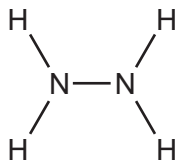

Consider **all** the electrons in a molecule of hydrazine.

Which description fits the arrangement of these electrons in the molecule?

	total number of electrons involved in bonding	total number of electrons not involved in bonding
A	5	4
B	5	8
C	10	4
D	10	8

- 11 Sodium hydrogencarbonate decomposes on heating.

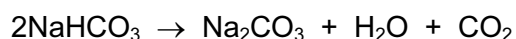

In an experiment, a 5.0 mol sample of sodium hydrogencarbonate is heated.

Which volume of carbon dioxide, measured at room temperature and pressure, is evolved?

- A** 24 dm³ **B** 36 dm³ **C** 48 dm³ **D** 60 dm³

- 12 Nitrogen and oxygen react according to the equation.

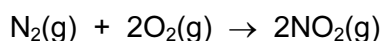

The enthalpy change for the reaction shown is +66 kJ.

If two moles of nitrogen and two moles of oxygen are used, what will be the enthalpy change?

- A** +16.5 kJ **B** +33 kJ **C** +66 kJ **D** +132 kJ

- 13 Which statement about the four gases carbon dioxide, CO_2 , hydrogen, H_2 , oxygen, O_2 and ozone, O_3 is correct?

- A** One mole of each gas occupies the same volume at a given temperature and pressure.
B Ozone has the fastest rate of diffusion at a given temperature and pressure.
C They are all denser than air.
D They are all elements.

14 When dilute sulfuric acid is electrolysed between inert electrodes, which statements are correct?

- 1 Hydrogen is released at the negative electrode.
- 2 Oxygen is released at the positive electrode.
- 3 Sulfur dioxide is released at the positive electrode.
- 4 The acid becomes more concentrated.

A 1, 2 and 4 **B** 1 and 2 only **C** 2 and 3 **D** 3 and 4

15 When electrolysed using inert electrodes, which dilute solution would produce the greatest increase in mass of the cathode?

[A_r : Al, 27; Cu, 64; Pb, 207; Ag, 108]

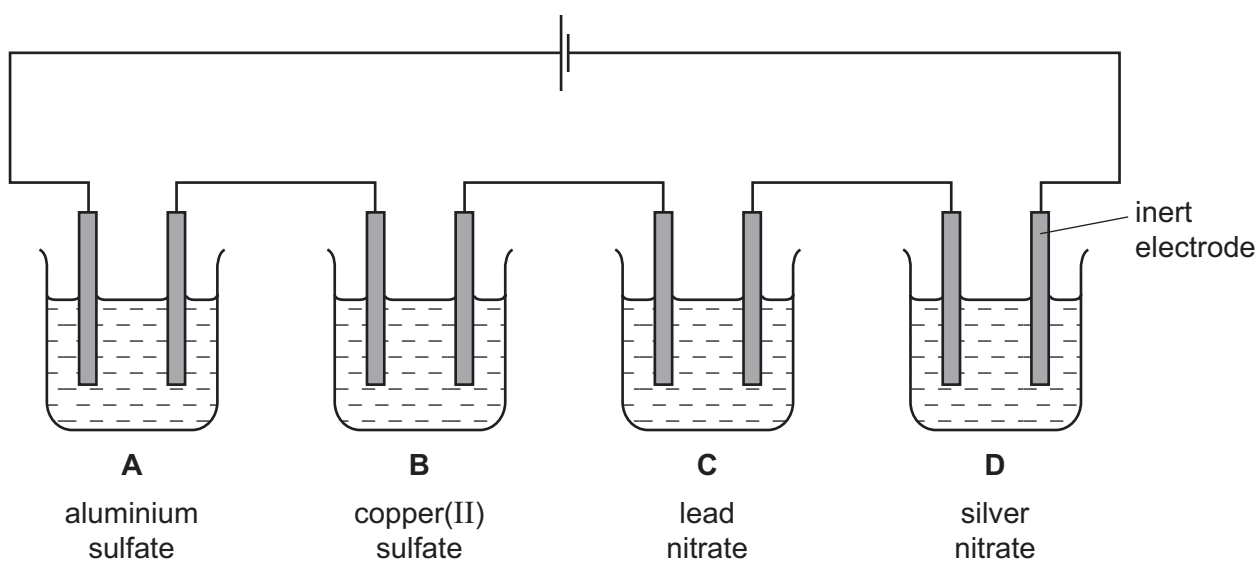

16 The formation of liquid water from hydrogen and oxygen is thought to occur in three stages.

- 1 $2\text{H}_2(\text{g}) + \text{O}_2(\text{g}) \rightarrow 4\text{H}(\text{g}) + 2\text{O}(\text{g})$
- 2 $4\text{H}(\text{g}) + 2\text{O}(\text{g}) \rightarrow 2\text{H}_2\text{O}(\text{g})$
- 3 $2\text{H}_2\text{O}(\text{g}) \rightarrow 2\text{H}_2\text{O}(\text{l})$

Which stages would be exothermic?

A 1, 2 and 3 **B** 1 and 2 only **C** 1 only **D** 2 and 3 only

- 17 When bismuth(III) chloride, BiCl_3 , is added to water, a white precipitate of BiOCl is formed.

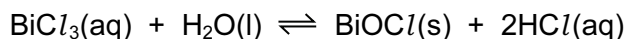

If this reversible reaction is at equilibrium and hydrochloric acid is added, what will happen?

- A The position of equilibrium moves to the left and more white precipitate is formed.
 - B The position of equilibrium moves to the left and the white precipitate disappears.
 - C The position of equilibrium moves to the right and more white precipitate is formed.
 - D The position of equilibrium moves to the right and the white precipitate disappears.
- 18 Which colour change occurs when ethanol is added to a small quantity of warm, acidified potassium dichromate(VI)?
- A orange to colourless
 - B orange to green
 - C purple to colourless
 - D purple to green

- 19 Sulfur and selenium, Se, are in the same group of the Periodic Table.

From this, we would expect selenium to form compounds having the formulae

- A Se_2O , Na_2Se and NaSeO_4 .
 - B SeO_2 , Na_2Se and NaSeO_4 .
 - C SeO_2 , Na_2Se and Na_2SeO_4 .
 - D SeO_3 , NaSe and NaSeO_4 .
- 20 When the product of a reaction between two gases is added to water, a solution of pH7 is formed.
- Which could be these gases?
- A hydrogen and chlorine
 - B hydrogen and nitrogen
 - C hydrogen and oxygen
 - D oxygen and carbon monoxide

- 21 When pure gas **X** was passed through the apparatus shown, the copper(II) oxide turned pink and the limewater stayed colourless.

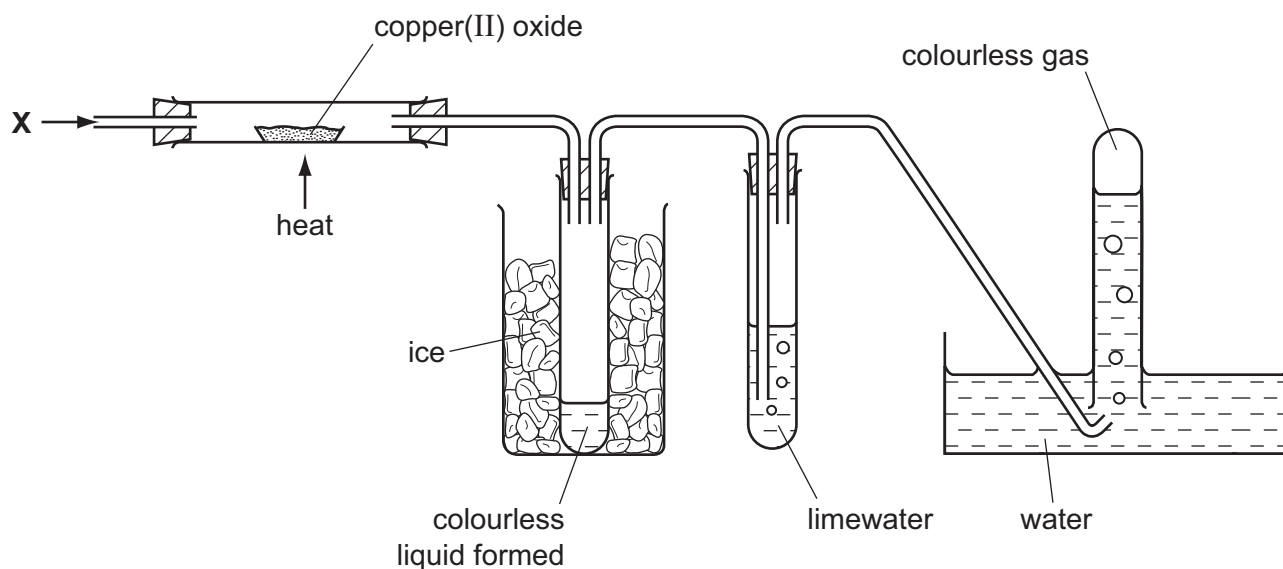

What is gas **X**?

- A carbon dioxide
 - B carbon monoxide
 - C hydrogen
 - D nitrogen
- 22 Which reagent is added to aqueous potassium chloride to prepare lead chloride?
- A aqueous lead nitrate
 - B lead
 - C lead carbonate
 - D lead sulfate
- 23 Which change in the properties of the halogens is **not** correct?

	chlorine → bromine → iodine
A	darker in colour
B	decrease in melting point
C	decrease in rate of diffusion
D	increase in density

24 *W*, *X* and *Y* are elements in the same period of the Periodic Table.

- *X* forms compounds of formulae XCl_2 and XCl_3 .
- *Y* forms a solution of pH12 when it reacts with water.
- The reaction of *W* with water is similar to the reaction of *Y* with water but is less vigorous.

In which order are the elements in the Periodic Table?

	left to right along a period
A	$W \rightarrow Y \rightarrow X$
B	$X \rightarrow W \rightarrow Y$
C	$X \rightarrow Y \rightarrow W$
D	$Y \rightarrow W \rightarrow X$

25 The diagram shows the structure of an alloy.

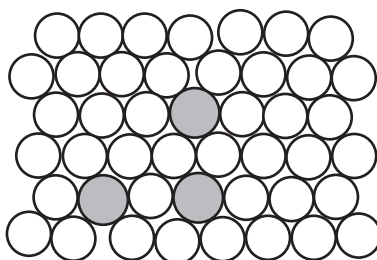

Which statement about alloys is correct?

- A** Alloys can only be formed by mixing copper or iron with other metals.
- B** High carbon steel alloys are soft and easily shaped.
- C** In an alloy there is attraction between positive ions and delocalised electrons.
- D** The alloy brass has a chemical formula.

26 The metals iron, lead and zinc can be manufactured by the reduction of their oxides with coke.

What is the correct order of the ease of reduction of the metal oxides?

	oxides become more difficult to reduce →
A	iron → lead → zinc
B	iron → zinc → lead
C	lead → iron → zinc
D	zinc → iron → lead

27 Aluminium is manufactured by the electrolysis of molten aluminium oxide.

Which gas is **not** formed during this process?

- A carbon dioxide
- B carbon monoxide
- C oxygen
- D sulfur dioxide

28 Which diagram correctly illustrates the conditions necessary for the rusting of iron and also the metal that can be used to prevent rusting by sacrificial protection?

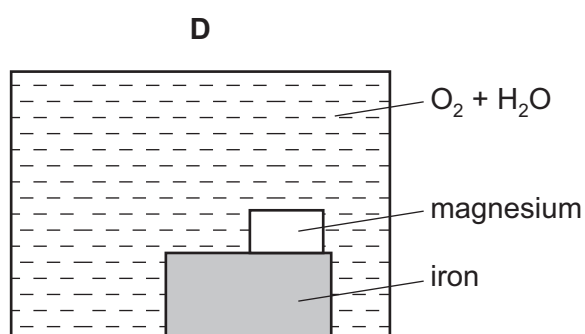
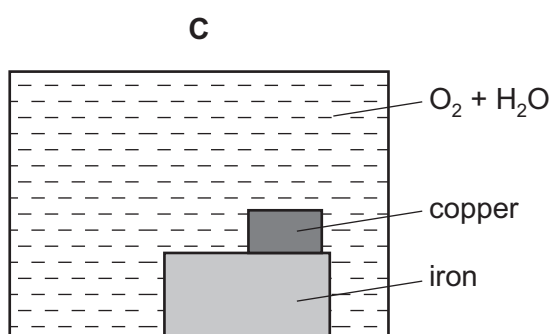
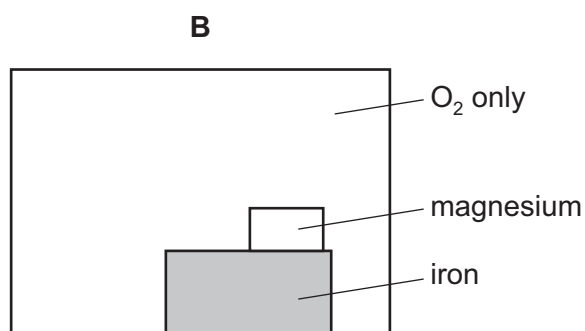
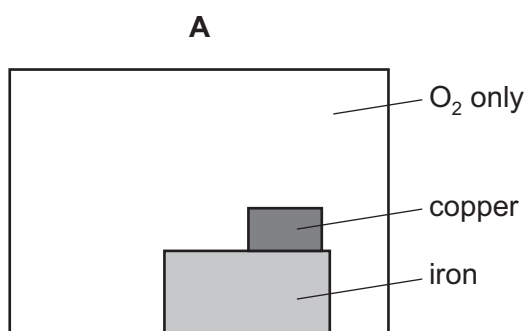

29 Metals usually occur in their ore combined with another element.

Which metal is least likely to occur combined with another element?

- A aluminium
- B calcium
- C magnesium
- D silver

30 The noble gases, argon, helium, krypton and xenon, are present in air.

Which noble gas is present in the largest proportion?

- A argon
- B helium
- C krypton
- D xenon

31 The following stages happen during eutrophication.

- 1 increase in growth of algae
- 2 increase in nitrate concentration
- 3 death of aquatic plants
- 4 decrease in dissolved oxygen

In which order do these stages occur?

- A 1 → 2 → 3 → 4
- B 1 → 2 → 4 → 3
- C 2 → 1 → 3 → 4
- D 2 → 1 → 4 → 3

32 Which gas will react with ozone in the upper atmosphere of the Earth?

- A CF_2Cl_2 B CH_4 C CO_2 D SO_2

33 Iron is extracted from iron ore in a blast furnace.

Which solid substances are fed into the top of the blast furnace?

- 1 coke
 - 2 cryolite
 - 3 limestone
- A 1, 2 and 3 B 1 and 2 only C 1 and 3 only D 2 and 3 only

34 The diagram shows a simplified structure of a fat.

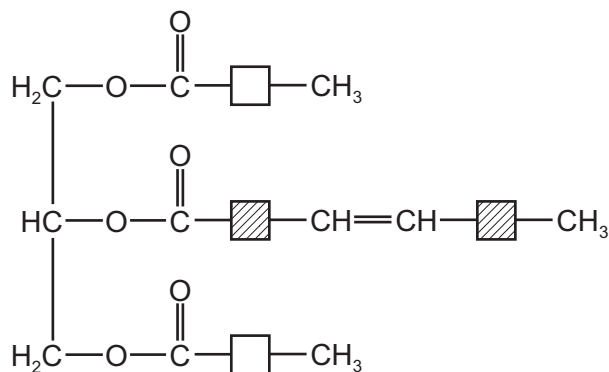

Which compounds in the table have linkages that can be found in this fat? (Do **not** consider C–H or C–C bonds as linkages.)

	ethene	nylon	<i>Terylene</i>
A	✓	✓	✓
B	✓	✓	x
C	✓	x	✓
D	x	✓	✓

35 The solubility of the carboxylic acids in water decreases as the size of the carboxylic acid molecules increases.

Which carboxylic acid is the least soluble in water?

- A** butanoic acid
- B** ethanoic acid
- C** methanoic acid
- D** propanoic acid

36 Poly(ethene) is the addition polymer formed from the monomer ethene.

Which statement is correct?

- A** Poly(ethene) can be disposed of by burning – this produces carbon dioxide and water.
- B** Poly(ethene) decolourises bromine water.
- C** Poly(ethene) has the empirical formula C_2H_4 .
- D** Poly(ethene) is acted upon by bacteria so that it decomposes quickly when in a landfill site.

37 The diagram shows the fractionation of crude oil.

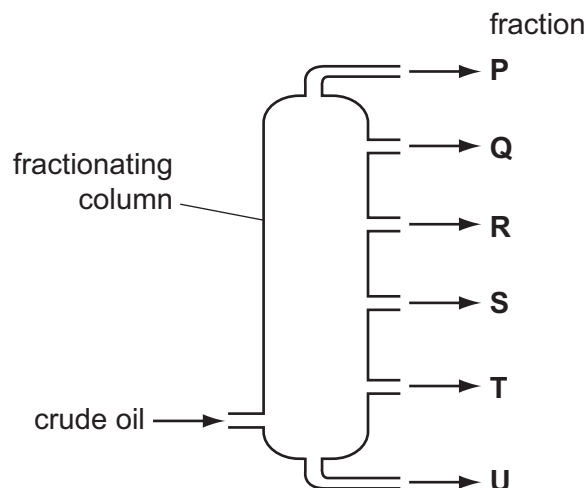

Which row explains why fraction **R** is collected above fraction **S**?

	boiling point of R	average molecular mass of R
A	higher than S	greater than S
B	higher than S	smaller than S
C	lower than S	greater than S
D	lower than S	smaller than S

38 In the manufacture of ethanoic acid, the chemical industry uses the following sequence of reactions.

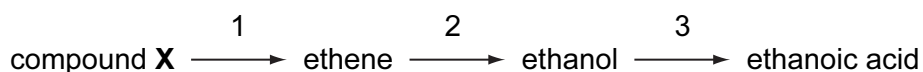

What are the three processes?

	1	2	3
A	cracking	hydration	oxidation
B	cracking	polymerisation	hydration
C	hydration	polymerisation	oxidation
D	polymerisation	oxidation	hydration

39 Esters are formed when an alcohol reacts with a carboxylic acid.

Which ester would be formed using the carboxylic acid and alcohol shown?

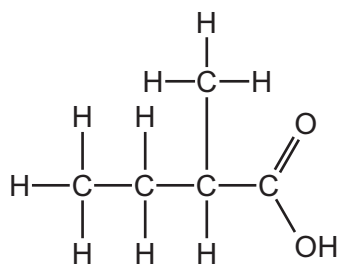

carboxylic acid

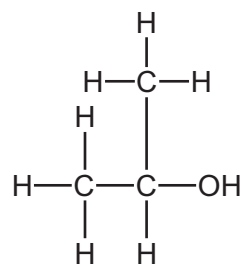

alcohol

A

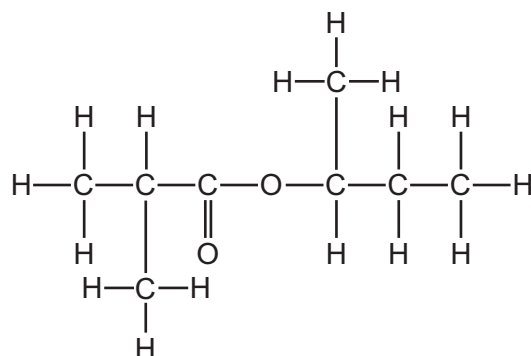

B

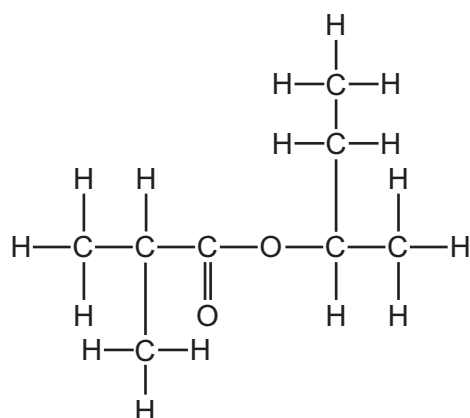

C

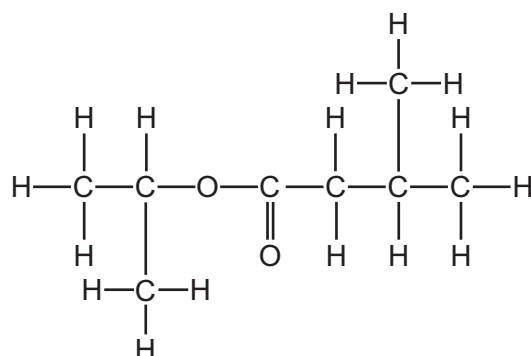

D

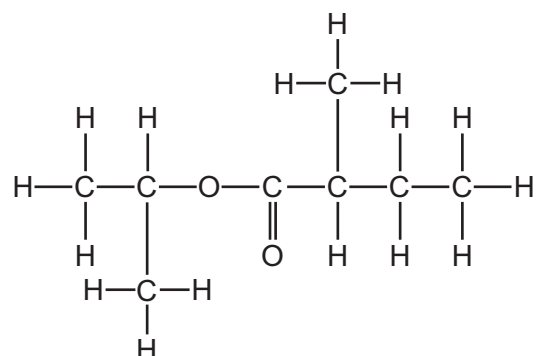

40 Which equation represents a combustion reaction?

- A $\text{C}_2\text{H}_4 + \text{H}_2\text{O} \rightarrow \text{C}_2\text{H}_5\text{OH}$
- B $\text{C}_2\text{H}_5\text{OH} + \text{O}_2 \rightarrow \text{CH}_3\text{CO}_2\text{H} + \text{H}_2\text{O}$
- C $\text{CH}_3\text{CO}_2\text{H} + 2\text{O}_2 \rightarrow 2\text{CO}_2 + 2\text{H}_2\text{O}$
- D $\text{CH}_3\text{CO}_2\text{H} + \text{CH}_3\text{OH} \rightarrow \text{CH}_3\text{CO}_2\text{CH}_3 + \text{H}_2\text{O}$

DATA SHEET
The Periodic Table of the Elements

		Group																																																																	
I	II	III	IV	V	VI	VII	0																																																												
7 Li Lithium 3	9 Be Beryllium 4	1 H Hydrogen 1	11 B Boron 5	12 C Carbon 6	14 N Nitrogen 7	16 O Oxygen 8	19 F Fluorine 9	20 Ne Neon 10	23 Na Sodium 11	24 Mg Magnesium 12	27 Al Aluminium 13	28 Si Silicon 14	31 P Phosphorus 15	32 S Sulfur 16	35.5 Cl Chlorine 17	40 Ar Argon 18	39 K Potassium 19	40 Ca Calcium 20	45 Sc Scandium 21	48 Ti Titanium 22	51 V Vanadium 23	52 Cr Chromium 24	55 Mn Manganese 25	56 Fe Iron 26	59 Co Cobalt 27	59 Ni Nickel 28	64 Cu Copper 29	65 Zn Zinc 30	70 Ga Gallium 31	73 Ge Germanium 32	75 As Arsenic 33	79 Se Selenium 34	80 Br Bromine 35	84 Kr Krypton 36	85 Rb Rubidium 37	88 Sr Strontium 38	89 Y Yttrium 39	91 Zr Zirconium 40	93 Nb Niobium 41	96 Mo Molybdenum 42	101 Ru Ruthenium 44	106 Pd Palladium 46	112 Cd Cadmium 48	115 In Indium 49	119 Sn Tin 50	122 Sb Antimony 51	127 I Iodine 53	131 Xe Xenon 54	133 Cs Caesium 55	137 Ba Barium 56	139 La Lanthanum 57	178 Hf Hafnium 72	181 Ta Tantalum 73	184 W Tungsten 74	190 Os Osmium 76	192 Ir Iridium 77	195 Pt Platinum 78	197 Au Gold 79	201 Hg Mercury 80	204 Tl Thallium 81	207 Pb Lead 82	209 Bi Bismuth 83	210 Po Polonium 84	210 At Astatine 85	210 Rn Radon 86	226 Ra Radium 88	227 Ac Actinium 89
												140 Ce Cerium 58	141 Pr Praseodymium 59	144 Nd Neodymium 60	150 Sm Samarium 62	152 Eu Europium 63	157 Gd Gadolinium 64	159 Tb Terbium 65	162 Dy Dysprosium 66	165 Ho Holmium 67	167 Er Erbium 68	169 Tm Thulium 69	173 Yb Ytterbium 70	175 Lu Lutetium 71	232 Th Thorium 90	238 U Uranium 92	238 Np Neptunium 93	238 Pu Plutonium 94	238 Am Americium 95	238 Cm Curium 96	238 Bk Berkelium 97	238 Cf Californium 98	238 Es Einsteinium 99	238 Fm Fermium 100	238 Md Mendelevium 101	238 No Nobelium 102	238 Lr Lawrencium 103																														

*58-71 Lanthanoid series
†90-103 Actinoid series

Key

a	X	a = relative atomic mass
b	X	X = atomic symbol
		b = proton (atomic) number

The volume of one mole of any gas is 24 dm³ at room temperature and pressure (r.t.p.).

Permission to reproduce items where third-party owned material protected by copyright is included has been sought and cleared where possible. Every reasonable effort has been made by the publisher (UCLES) to trace copyright holders, but if any items requiring clearance have unwittingly been included, the publisher will be pleased to make amends at the earliest possible opportunity.

Cambridge International Examinations is part of the Cambridge Assessment Group. Cambridge Assessment is the brand name of University of Cambridge Local Examinations Syndicate (UCLES), which is itself a department of the University of Cambridge.