



**Cambridge International Examinations**  
Cambridge Ordinary Level

---

**PHYSICS**

**5054/32**

Paper 3 Practical Test

**October/November 2017**

CONFIDENTIAL INSTRUCTIONS

**Great care should be taken to ensure that any confidential information given does not reach the candidates either directly or indirectly.**

**No access to the Question Paper is permitted in advance of the examination.**

---



If you have any problems or queries regarding these Instructions, please contact Cambridge stating the Centre number, the nature of the query and the syllabus number quoted above.

email      info@cie.org.uk  
phone     +44 1223 553554  
fax        +44 1223 553558

---

This document consists of **11** printed pages and **1** blank page.

### Instructions for preparing apparatus

These Confidential Instructions detail the apparatus required for each experiment in this paper. No access is permitted to the Question Paper in advance of the examination session.

### Number of sets of apparatus

In addition to a few spare sets, the minimum number of sets of apparatus to be provided should be sufficient to enable candidates to spend 20 minutes with the apparatus for each of Questions 1, 2 and 3, and one hour with the apparatus for Question 4. The order in which candidates answer the questions will be determined by the Supervisor. Candidates may spend one hour circulating around Questions 1, 2 and 3, followed by an hour on Question 4, or vice versa.

It is assumed that candidates will supply their own calculator and geometrical instruments, such as a set square,  $0^\circ$  to  $180^\circ$  protractor, pair of compasses and 30 cm ruler. Candidates should be advised in advance that they may, if they wish, use wristwatches with stopwatch facilities, providing that such wristwatches afford the required precision.

### Instructions for the supervision of the examination

The Supervisor, who may be a physics teacher, is responsible for the administration of the examination according to the procedures detailed in the Handbook for Centres. In all instances, a physics teacher should be present. Preferably, this teacher should have been responsible for the preparation of the apparatus. Two invigilators must be present at all times: it is not acceptable for a teacher who has been responsible for preparing the candidates for this paper to be the sole Supervisor or Invigilator.

Supervisors may make the following announcement at the start of the examination.

‘The Examiners do not want you to waste time if you are unable to do any experiment. Any candidate who is unable to get results with an experiment may ask for help. The extent of the help given will be reported to the Examiners, who may make a deduction of marks.’

Supervisors should note that a candidate may only be given enough assistance to allow some raw readings or observations to be made. On no account should any assistance be given with the treatment or analysis of these readings and observations.

Supervisors may draw to the attention of the candidates any significant deviation between the apparatus provided and that detailed in the Question Paper, particularly where diagrams are given in the paper.

Candidates should be reminded that all their work should be written on the Question Paper. Rough paper must not be used.

The Supervisor must complete the Report at the back of these Instructions. Details should be given of any significant deviation between the apparatus used and that specified in these Instructions. A sample set of results can often help Examiners. A copy of this Report must be included in **each** packet of scripts.

**Question 1****Items to be supplied by the Centre (per set of apparatus, unless otherwise specified)**

Two expendable steel springs, with a spring constant of approximately 25 N/m, e.g. Griffin catalogue number 12463080 or legacy number XBV-590-010H (see Note 1).

100g mass hanger and seven 100g slotted masses (see Note 2).

Stand, boss and clamp to support the two springs.

Blu-tack.

Second clamp and boss to act as a fiducial marker.

Stopwatch, to a precision of at least 0.1 s.

**Notes**

1. The springs should be as identical as possible.
2. The slotted masses should be placed on the hanger and taped together. The total mass of 800g should be labelled M.
3. The Supervisor should set up the apparatus as shown in Fig. 1.1. The loops at the tops of the springs should be about 2cm apart on the rod of the clamp and each held in place by a small piece of Blu-tack. The hook of the mass hanger should pass through the bottom loop of both springs. The second clamp should be held on the same stand, close to the bottom of the stand. The rod of the clamp should be on the same side as the springs.

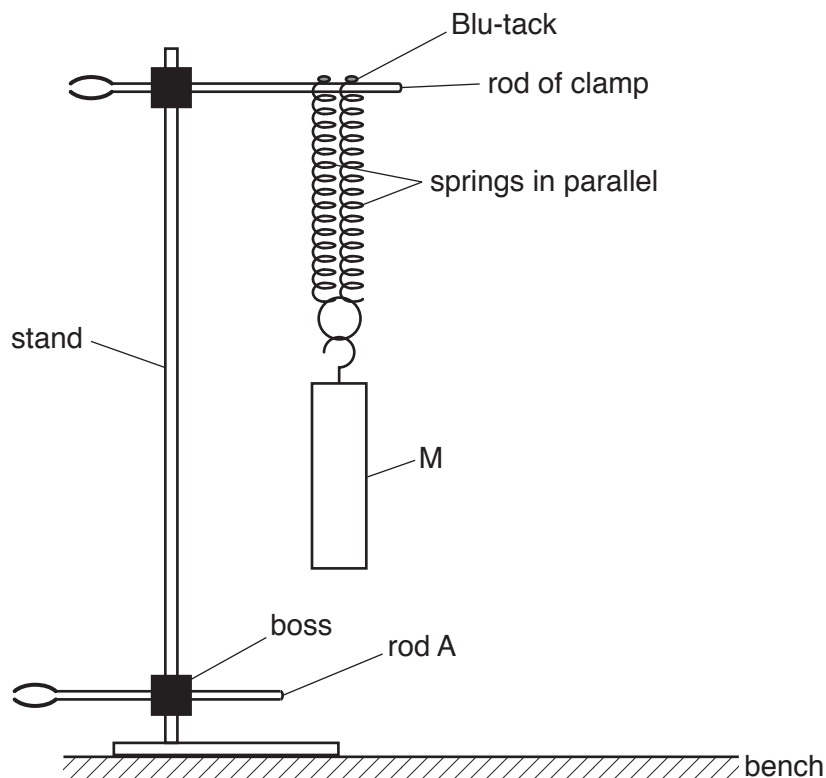
**Fig. 1.1**

4. At the changeover the Supervisor should restore the apparatus as shown in Fig. 1.1. The mass  $M$  will need to be suspended from both springs and the second clamp moved to the bottom of the stand.

**Information required by Examiners**

Sample set of numerical results, clearly labelled “Supervisor’s Results”, obtained out of sight of the candidates.

**Question 2****Items to be supplied by the Centre (per set of apparatus, unless otherwise specified)**

4.5 V to 5 V d.c. power supply (see Note 1).

Switch or plug key.

Negative temperature coefficient disc thermistor (see Note 2).

Resistor of nominal value  $2.2\text{ k}\Omega$  (see Note 3).

Voltmeter capable of measuring a potential difference of up to 5.0 V to a precision of 0.1 V or better. An analogue or digital meter is suitable.

$250\text{ cm}^3$  beaker containing about  $200\text{ cm}^3$  of water at room temperature (see Note 4).

$250\text{ cm}^3$  beaker containing about  $200\text{ cm}^3$  of an ice and water mixture.

Connecting leads (see Note 5).

Card on which is printed "Component X" (see Note 6).

Stirrer.

Paper towels or cloths to mop up spillages.

**Notes**

1. The following are suitable power sources but all the candidates at a centre must be supplied with the same type of source.
  - three 1.5 V dry cells in suitable holders connected in series,
  - four 1.2 V rechargeable cells in suitable holders connected in series,
  - d.c. power supply of 4.5 V or 5 V.

If a variable d.c. power supply is used, the variable control should be taped to prevent candidates altering the output voltage.

2. A suitable disc thermistor has a resistance of about  $500\ \Omega$  at  $25^\circ\text{C}$  and  $1500\ \Omega$  at  $0^\circ\text{C}$ . The RS component code of such a thermistor is RS 191-2229. The thermistor will require long leads as the beakers of water at room temperature and the ice and water mixture will be separated from the remainder of the circuit. The ends of the leads should have suitable terminals to enable them to be connected into the remainder of the circuit. The thermistor should be labelled X with a permanent marker pen.
3. The value of the resistor should be concealed from the candidates and the resistor should be labelled R. The resistor should have suitable terminals to enable it to be connected into the remainder of the circuit. The RS component code of a suitable resistor is RS 135-881.
4. A container containing sufficient water for all candidates should be left overnight in the laboratory prior to the examination so that it is at the temperature of the laboratory.

5. The Supervisor should set up the apparatus as shown in Fig. 2.1. Supervisors should check that when the thermistor is placed in the beaker of water at room temperature the reading on the voltmeter is in the region of 4 V. If a different thermistor to that described in Note 2 is used then the value of  $R$  will need to be changed. Generally a larger value of  $R$  will give a larger reading on the voltmeter.

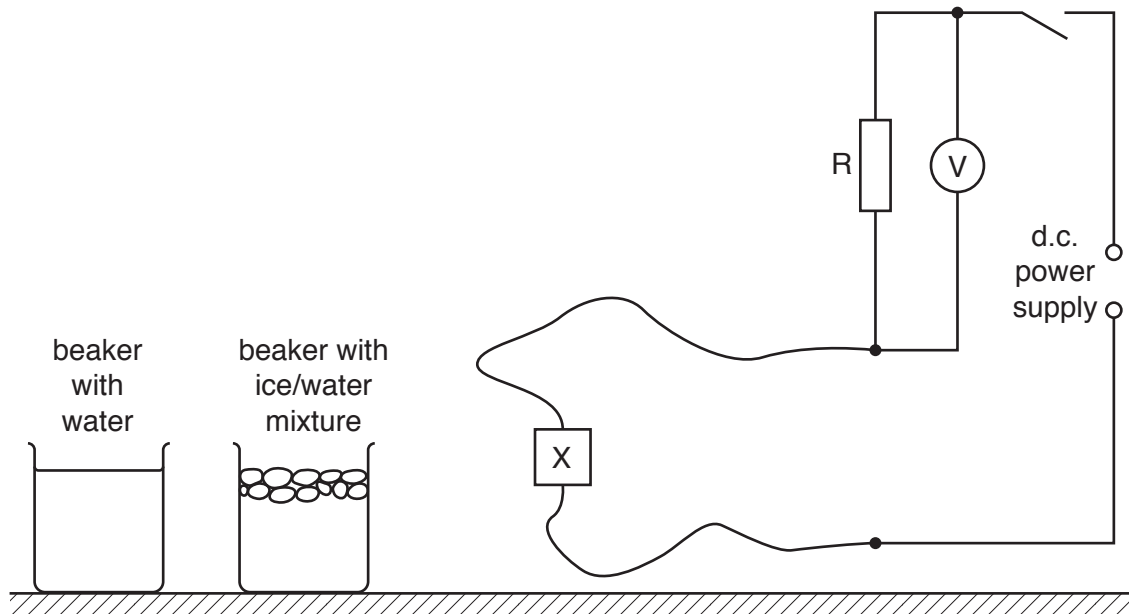

Fig. 2.1

6. After testing the circuit, the thermistor should be removed from the water, dried and placed on the card on the bench. The thermistor should remain connected to the circuit with the switch opened.
7. At the changeover, the Supervisor should
- ensure that there is sufficient ice in the ice and water mixture,
  - remove the thermistor from one of the beakers, dry it and place it on the card. The thermistor should be still connected to the circuit with the switch open,
  - ensure that the apparatus has been restored to its original state as in Fig. 2.1. If cells are used in the circuit, they should be checked and replaced, if necessary.

### Information required by Examiners

Sample set of numerical results, clearly labelled “Supervisor’s Results”, obtained out of sight of the candidates.

If a different value of  $R$  is used, Supervisors should record the value of the resistance used.

**Question 3****Items to be supplied by the Centre (per set of apparatus, unless otherwise specified)**

Ramp (see Note 1).

Glass sphere of diameter between 1 cm and 2 cm, e.g. a marble.

Fine dry sand (see Note 2).

Tray to hold the sand (see Note 3).

Two metre rules with mm divisions.

Piece of stiff card, wide enough to smooth the sand in the tray.

**Notes**

1. The ramp should be made of stiff wood and have a minimum length of 60 cm. It should be inclined at an angle of approximately  $15^\circ$  to the horizontal. The bottom of the ramp should be supported about 10 cm above the bench, hence, for a 60 cm ramp, the top of the ramp should be about 25 cm above the bench to create this angle. Supervisors should ensure that the glass sphere will roll down the ramp when it is set at this angle. The ramp should be fixed to the supports so that it does not move, e.g. use of Blu-tack.
2. Any commercially available fine sand will do but it is important that the sand is dry. It may be necessary to dry the sand in an oven at low temperature. The glass sphere will roll down the ramp from a point that is 50.0 cm from the bottom of the ramp. It will roll off the end of the ramp to land in the sand. It is important that the glass sphere will leave an imprint in the sand when this procedure is carried out. As long as the initial landing point is clear it does not matter if the sphere rolls along the sand.
3. The Supervisor should set up the apparatus as shown in Fig. 3.1 with one end of the tray vertically below the lower edge of the ramp. The Supervisor should try out the procedure described in Note 2. If the sphere overshoots the tray, then a longer tray should be used. The position of the tray should then be marked so that it can easily be returned to this position at the changeover.

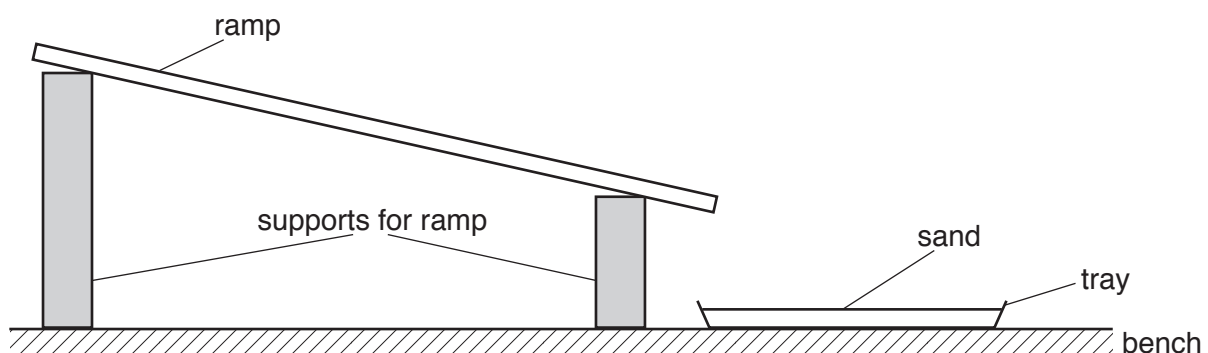
**Fig. 3.1**

4. At the changeover the Supervisor should ensure that the apparatus is set up as in Fig. 3.1. The surface of the sand should be smooth and the metre rules should be on the bench.

**Information required by Examiners**

Sample set of numerical results, clearly marked "Supervisor's Results", obtained out of sight of the candidates.

**Question 4****Items to be supplied by the Centre (per set of apparatus, unless otherwise specified)**

Two expendable steel springs, with a spring constant of approximately 25 N/m, e.g. Griffin catalogue number 12463080 or legacy number XBV-590-010H (see Note 1).

Stand, boss and clamp to support the parallel spring arrangement (see Note 2).

S-hook.

Wooden metre rule with mm divisions (see Note 3).

Two pieces of thin string, each of approximate length 10 cm (see Note 3).

Second boss and clamp to loosely pivot the metre rule at the 10 cm mark (see Note 4).

10 g slotted mass hanger with nine 10 g slotted masses.

300 mm ruler with mm divisions.

Set square.

**Notes**

1. The springs should be as identical as possible. The springs are to be connected in parallel. This can be done by tying together the two loops at one end of the springs and the two loops at the opposite ends of the springs.
2. Supervisors should label the clamp on this stand as “clamp B”.
3. The metre rule should be stiff. Holes should be drilled in the metre rule at the 30.0 cm mark and the 90.0 cm mark. A loose loop of thin string should then pass through each hole. One loop will support the 10 g slotted mass hanger and the S-hook will pass through the other loop.
4. The Supervisor should
  - Label this clamp as “clamp A”.
  - Tighten the jaws of clamp A at the 10.0 cm mark across the edges of the metre rule. The graduated face of the rule should be vertical and face the candidate and the rod of the clamp should be horizontal.
  - The rod of clamp A should be placed loosely in the boss as shown in Fig. 4.1.
  - The screw attaching the boss to the stand should be firmly tightened. The screw attaching the rod of clamp A to the boss should not be fully tightened, so that the rod and rule can rotate freely in the boss.



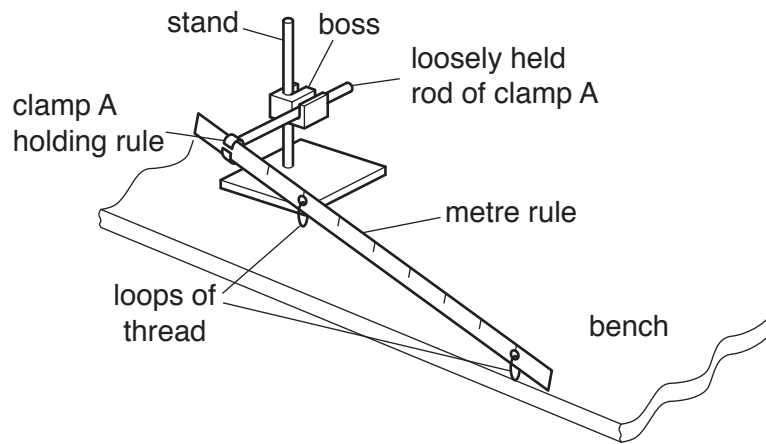

Fig. 4.1

5. The Supervisor should set up the apparatus as shown in Fig. 4.2. The Supervisor should ensure that it is possible to hang the mass hanger and nine 10g masses from the loop at the 90.0 cm mark and to adjust the height of clamp B to make the rule horizontal. The Supervisor should then remove the mass hanger and masses from the rule and unhook the rule from the S-hook.

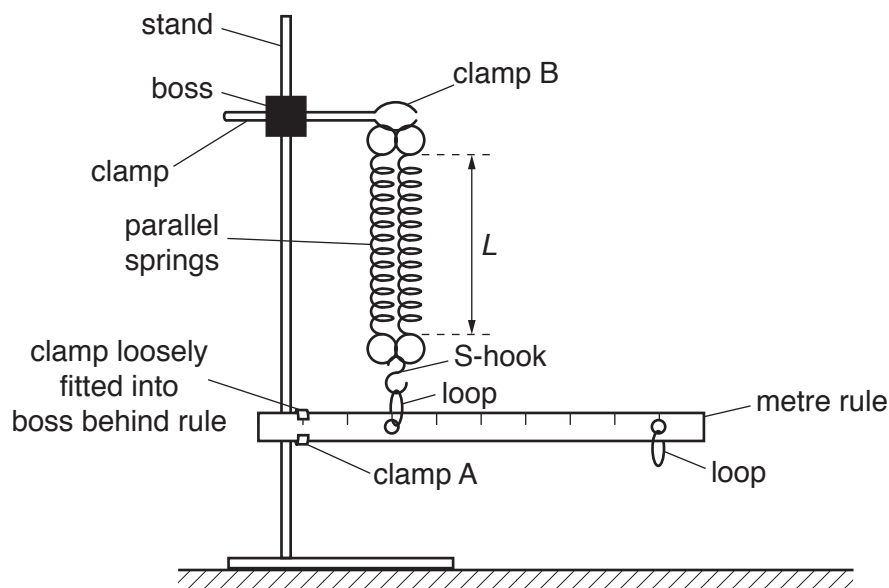

Fig. 4.2 (front view)

6. At the changeover, the Supervisor should
- remove the mass hanger and masses from the rule,
  - unhook the rule from the S-hook.

### Information required by Examiners

Sample set of numerical results, clearly marked “Supervisor’s Results”, obtained out of sight of the candidates.

**BLANK PAGE**

---

Permission to reproduce items where third-party owned material protected by copyright is included has been sought and cleared where possible. Every reasonable effort has been made by the publisher (UCLES) to trace copyright holders, but if any items requiring clearance have unwittingly been included, the publisher will be pleased to make amends at the earliest possible opportunity.

To avoid the issue of disclosure of answer-related information to candidates, all copyright acknowledgements are reproduced online in the Cambridge International Examinations Copyright Acknowledgements Booklet. This is produced for each series of examinations and is freely available to download at [www.cie.org.uk](http://www.cie.org.uk) after the live examination series.

Cambridge International Examinations is part of the Cambridge Assessment Group. Cambridge Assessment is the brand name of University of Cambridge Local Examinations Syndicate (UCLES), which is itself a department of the University of Cambridge.

**This form must be completed and returned with the candidates' scripts.**

### **REPORT ON PRACTICAL PHYSICS**

The Supervisor is asked to give the following details, using the space provided on page 12.

- (a)** Information required at the end of the test, as indicated in the Instructions.
- (b)** Any help given to a candidate.
- (c)** Any general difficulties encountered in preparing the apparatus.
- (d)** Any difficulties experienced by particular candidates. These should include reference to difficulties due to faulty apparatus or materials and accidental damage to apparatus or materials. Candidates should be identified by name and candidate number.

Other cases of hardship, such as disability or illness, should be reported to Cambridge in the normal way.

The Supervisor is asked to provide a plan of the work benches, giving details by candidate numbers of the places occupied by the candidates for each session. The plan and report should be enclosed in the envelope containing the candidates' scripts. If more than one envelope is used, a copy of the report must be enclosed in each envelope.

#### **Declaration to be signed by the Supervisor**

The preparation of this practical examination has been carried out so as to maintain fully the security of the examination.

Signed .....

Name (in block capitals) .....

Centre number .....

Centre name .....

**Information required**

For questions 1, 2, 3 and 4, please enclose a sample set of numerical results, obtained out of sight of the candidates and clearly labelled "Supervisor's Results".

**Details of difficulties and any help given to candidates**