



UNIVERSITY OF CAMBRIDGE INTERNATIONAL EXAMINATIONS
General Certificate of Education Ordinary Level

CANDIDATE
NAME

CENTRE
NUMBER

--	--	--	--	--

CANDIDATE
NUMBER

--	--	--	--

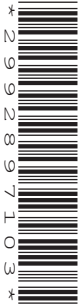

PHYSICS

5054/32

Paper 3 Practical Test

October/November 2013

2 hours

Candidates answer on the Question Paper.

Additional Materials: As listed in the Confidential Instructions.

READ THESE INSTRUCTIONS FIRST

Write your Centre number, candidate number and name on all the work you hand in.
Write in dark blue or black pen.
You may use a pencil for any diagrams, graphs or rough working.
Do not use staples, paper clips, highlighters, glue or correction fluid.
DO NOT WRITE IN ANY BARCODES.

Answer **all** questions.

For each of the questions in Section A, you will be allowed to work with the apparatus for a maximum of 20 minutes. For the question in Section B, you will be allowed to work with the apparatus for a maximum of 1 hour.

You are expected to record all your observations as soon as these observations are made.
An account of the method of carrying out the experiments is **not** required.

Electronic calculators may be used.
You may lose marks if you do not show your working or if you do not use appropriate units.

At the end of the examination, fasten all your work securely together.
The number of marks is given in brackets [] at the end of each question or part question.

For Examiner's Use	
1	
2	
3	
4	
Total	

This document consists of **11** printed pages and **1** blank page.



Section A

Answer **all** the questions in this section.

For
Examiner's
Use

1 In this experiment, you will determine the weight of a metal stand.

You have been provided with

- a metal stand labelled A,
- a knife-edge to act as a pivot,
- a support for the knife-edge,
- a metre rule,
- a spring,
- a clamp, boss and stand labelled B to support the spring.

(a) Measure the unstretched length l of the coil of the spring as shown in Fig. 1.1.

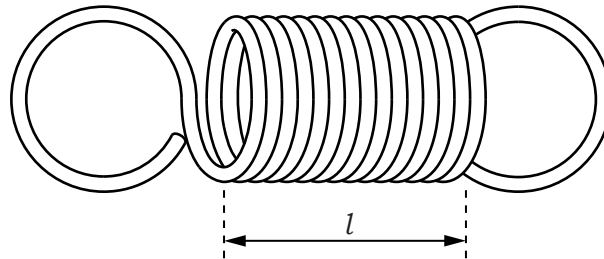

Fig. 1.1

$l = \dots\dots\dots$ [1]

(b) Set up the apparatus as shown in Fig. 1.2.

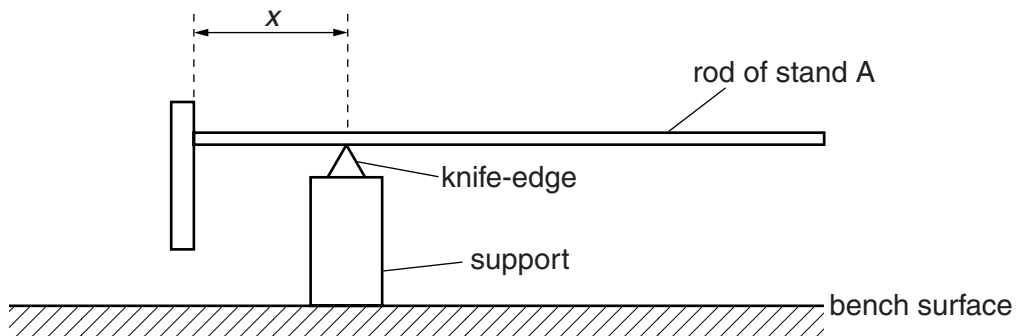

Fig. 1.2

Move the rod of stand A along the knife-edge until the rod balances horizontally, as shown in Fig. 1.2. Measure the distance x from the top of the base of stand A to the position of the knife-edge.

$x = \dots\dots\dots$ [1]

- (c) Lift stand A off the knife-edge and move the stand a few centimetres to the right. Replace stand A on the knife-edge. The right-hand end of the stand will move towards the bench.

Slide one of the loops of the spring on to the end of the rod and hold the other loop in the clamp. Adjust the height of the clamp until the rod is horizontal. The arrangement is shown in Fig. 1.3. Make the extension of the spring as large as possible by moving stand A further to the right. Adjust the height of the clamp so that the rod is horizontal and move stand B so that the spring is vertical.

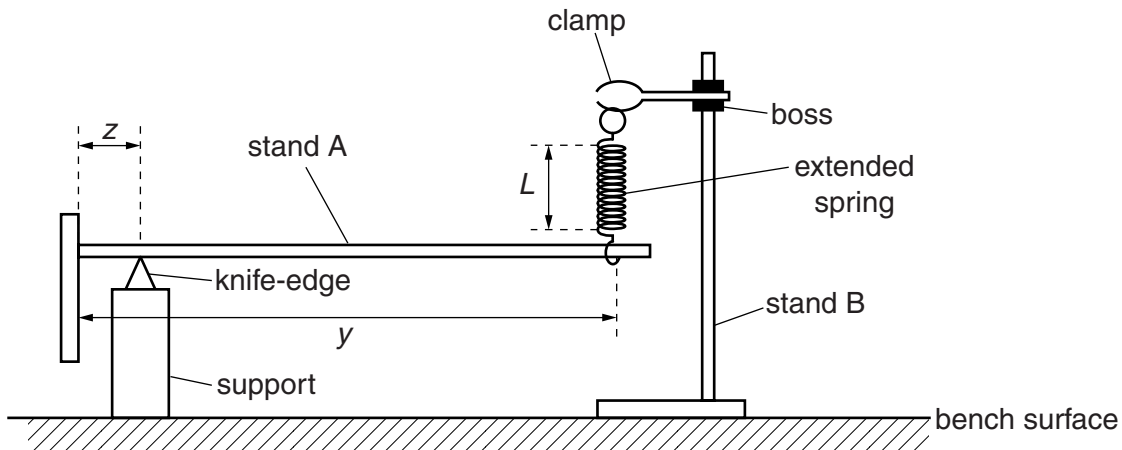

Fig. 1.3

Measure

- (i) the distance y from the top of the base of stand A to the spring,

$y = \dots\dots\dots$

- (ii) the distance z from the top of the base of stand A to the knife-edge,

$z = \dots\dots\dots$

- (iii) the stretched length L of the coil of the spring.

$L = \dots\dots\dots$

[2]

- (d) Calculate the weight W of stand A using the equation

$$W = \frac{k(L - l)(y - z)}{(x - z)}$$

where the constant k is 0.25 N/cm and all distances are in cm.

$W = \dots\dots\dots$ [1]

[Total: 5]

2 In this experiment, you will investigate the mixing of hot and cold water.

For
Examiner's
Use

You have been provided with

- an empty 250 cm³ beaker labelled A,
- a 250 cm³ beaker containing water at room temperature,
- a supply of hot water,
- a 100 cm³ measuring cylinder,
- a thermometer,
- a plastic stirrer,
- a stand, boss and clamp to hold the thermometer.

- (a) (i) Measure the temperature θ_1 of the water at room temperature.

$\theta_1 = \dots\dots\dots$

- (ii) Pour 50 cm³ of the water at room temperature into the measuring cylinder.
- (iii) Place the thermometer in the clamp and carefully tighten the jaws. The bottom of the bulb of the thermometer should be about 1 cm above the bench.
- (iv) Pour hot water into beaker A until the water level reaches the 100 cm³ mark. Place the thermometer in the hot water as shown in Fig. 2.1.

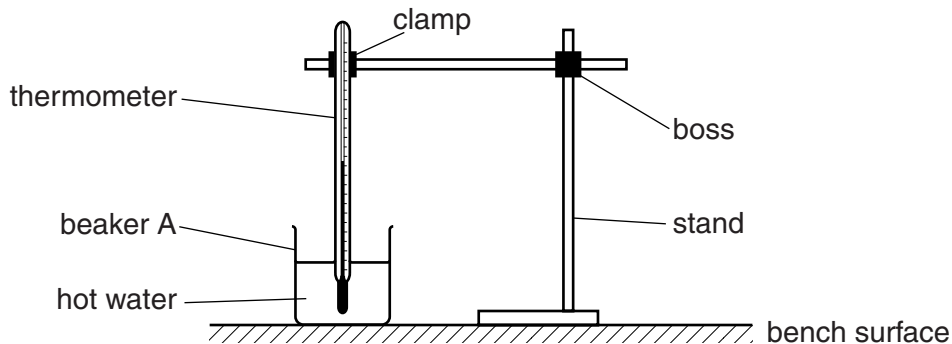

Fig. 2.1

Stir the water. Record the maximum temperature θ_2 shown on the thermometer before the temperature starts to fall.

$\theta_2 = \dots\dots\dots$

- (v) Immediately pour the 50 cm³ of water from the measuring cylinder into beaker A. Stir the mixture. The reading on the thermometer will fall quickly at first and then at a slower rate. As soon as it starts to fall at the slower rate, record the temperature θ_3 of the mixture.

$\theta_3 = \dots\dots\dots$

[3]

(b) The mass of 1.0 cm^3 of water is 1.0 g .

When water at room temperature is added to the hot water, thermal energy (heat) is lost by the hot water and thermal energy is gained by the water at room temperature.

The amount of thermal energy transferred is given by the equation

$$\text{thermal energy transfer} = \text{mass} \times \text{specific heat capacity} \times \text{change in temperature.}$$

The specific heat capacity of water is $4.2\text{ J}/(\text{g } ^\circ\text{C})$.

Calculate

(i) the thermal energy lost by the hot water,

energy lost by hot water =

(ii) the thermal energy gained by the water at room temperature.

energy gained by water at room temperature = [1]

(c) Explain any difference between your answers to (b)(i) and (b)(ii).

.....
.....
.....
..... [1]

[Total: 5]

3 In this experiment, you will investigate the resistance of a filament lamp.

For
Examiner's
Use

You have been provided with

- a 3V power supply,
- a switch,
- a 3.3Ω resistor,
- a 33Ω resistor,
- a filament lamp in a holder,
- an ammeter,
- a voltmeter with two connecting leads,
- two further connecting leads.

The Supervisor has set up the circuit shown in Fig. 3.1.

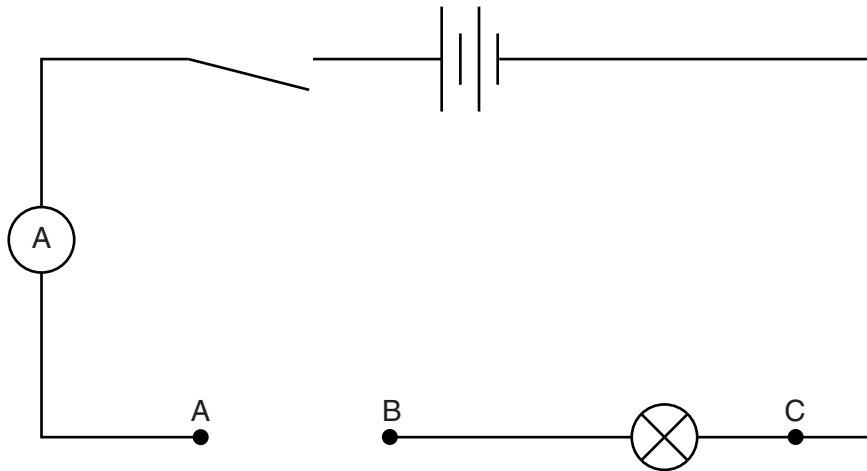

Fig. 3.1

- (a) Using the two spare leads, connect the 3.3Ω resistor between A and B. Connect the voltmeter between points B and C. Close the switch and record the potential difference (voltage) V_1 across the lamp and the current I_1 in the circuit. Open the switch.

$$V_1 = \dots\dots\dots$$

$$I_1 = \dots\dots\dots$$

[1]

- (b) Calculate the resistance R_1 of the lamp using the equation

$$R_1 = \frac{V_1}{I_1}.$$

$$R_1 = \dots\dots\dots[1]$$

- (c) Remove the 3.3Ω resistor from the circuit and replace it with the 33Ω resistor. Close the switch and record the new voltage V_2 across the lamp and the new current I_2 in the circuit. Open the switch.

$V_2 =$

$I_2 =$

[1]

- (d) Calculate the new resistance R_2 of the lamp using the equation

$$R_2 = \frac{V_2}{I_2}.$$

$R_2 =$ [1]

- (e) Explain any difference between your values for R_1 and R_2 .

.....
.....
.....
..... [1]

[Total: 5]

Section B

For
Examiner's
Use

- 4 In this experiment, you will investigate refraction in a transparent block and find a value for the refractive index of the material of the block.

You have been provided with

- a rectangular block,
- four optics pins,
- a soft board,
- a protractor,
- a 30 cm ruler.

- (a) Fig. 4.2 is on page 9 of your question paper. On Fig. 4.2,

- (i) draw a normal to the line XY at the point M, above and below the line XY,
 (ii) draw a line from M, at an angle of 50° to the normal, towards the top left of the page. Label this line L. This line represents the ray incident on the block. The angle of incidence i is 50° . [1]

- (b) Place the block, with one of its long sides on the line XY, on Fig. 4.2. The top left-hand corner of the block should be at X, as shown in Fig. 4.1.



Fig. 4.1

- (c) Draw the outline of the block on Fig. 4.2.

- (d) (i) Remove the block and place page 9 of the question paper on the soft board. Replace the block in the position shown by the outline and place two optics pins vertically into the page on the line L. These pins should be as far apart as possible. On line L, label the positions of the two pins P_1 and P_2 .

View the two pins through the block from the bottom of the block. Move your head until the images of P_1 and P_2 are in line. Place two more pins in line with the single image that you can see. Label these two pins P_3 and P_4 . These two pins indicate the position of the emergent ray. They should be placed below the block in such positions that the path of the emergent ray is determined as accurately as possible.

- (ii) Remove the block. Draw a line through P_3 and P_4 that just touches the outline of the block at a point. Label this point N.

- (iii) Draw a straight line from M to N. This represents the refracted ray in the block.
- (iv) Measure the angle of refraction r at M.

*For
Examiner's
Use*

$r =$ [3]



Fig. 4.2

- (e) Repeat (d) for different angles of incidence at M. For each angle of incidence i , obtain the corresponding angle of refraction r .

For
Examiner's
Use

Record your results in a table. Include in your table columns for i , r , $\sin i$ and $\sin r$. Also include your result from (d).

[5]

- (f) Using the grid opposite, plot a graph of $\sin i$ against $\sin r$. Draw a straight line of best fit through your points. [4]

- (g) Determine the gradient of the line of best fit.

gradient = [2]

For
Examiner's
Use

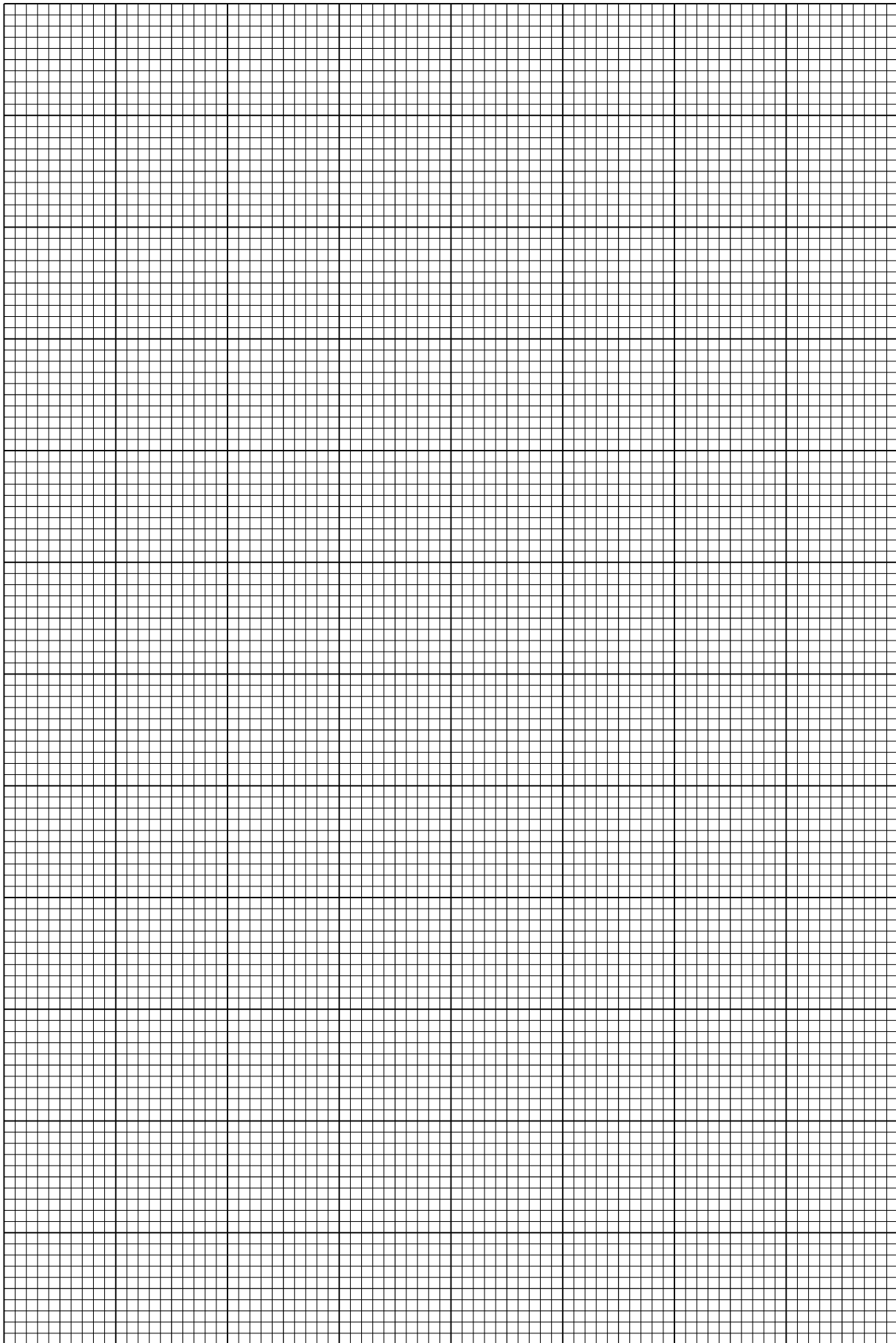

[Total: 15]

BLANK PAGE

Permission to reproduce items where third-party owned material protected by copyright is included has been sought and cleared where possible. Every reasonable effort has been made by the publisher (UCLES) to trace copyright holders, but if any items requiring clearance have unwittingly been included, the publisher will be pleased to make amends at the earliest possible opportunity.

University of Cambridge International Examinations is part of the Cambridge Assessment Group. Cambridge Assessment is the brand name of University of Cambridge Local Examinations Syndicate (UCLES), which is itself a department of the University of Cambridge.