

UNIVERSITY OF CAMBRIDGE INTERNATIONAL EXAMINATIONS
General Certificate of Education Ordinary Level

PHYSICS

5054/03

Paper 3 Practical Test

October/November 2005

2 hours

Additional Materials: As specified in the Confidential Instructions

READ THESE INSTRUCTIONS FIRST

Follow the instructions on the front cover of the Answer Booklet.
Write your answers in the spaces provided in the Answer Booklet.

Answer **all** questions.

For each of the questions in Section A, you will be allowed to work with the apparatus for a maximum of 20 minutes. For the question in Section B, you will be allowed to work with the apparatus for a maximum of 1 hour.

You are expected to record all your observations as soon as these observations are made.

An account of the method of carrying out the experiments is **not** required.

At the end of the examination, hand in only the Answer Booklet.

This document consists of **5** printed pages, **3** blank pages and an enclosed Answer Booklet.



Section A

- 1 In this experiment you will make some measurements on a steel spring in order to find an approximate value for the density of the material of the spring.

You have been provided with a steel spring, a 30 cm rule and two set squares. You have access to a balance.

- (a) Ensure that the turns of the spring are pushed together and measure the length l of the coiled part of the spring, as shown in Fig. 1.1. Record the length l on page 3 of your Answer Booklet. [1]

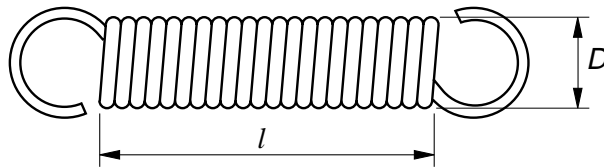

Fig. 1.1

- (b) Count the number N of turns in the coiled part of the spring. [1]
- (c) Determine the diameter D of the spring. [1]
- (d) Use the balance to measure the mass M of the spring. Hence determine an approximate value for the density of the material from which the spring is made, given that

$$\text{approximate density} = \frac{4MN}{\pi^2 l^2 D}$$

[2]

- 2 In this experiment you will measure the extension of a spring caused by the weight of a mass, when the mass is suspended in air and when the mass is immersed in water. From these measurements you will determine the density of the material of the mass.

You have been provided with a spring, a stand with two clamps, a metre rule, a beaker containing water and a 500 g mass.

- (a) Suspend the spring from the clamp on the stand. Clamp a vertical metre rule close to the spring, as shown in Fig. 2.1.

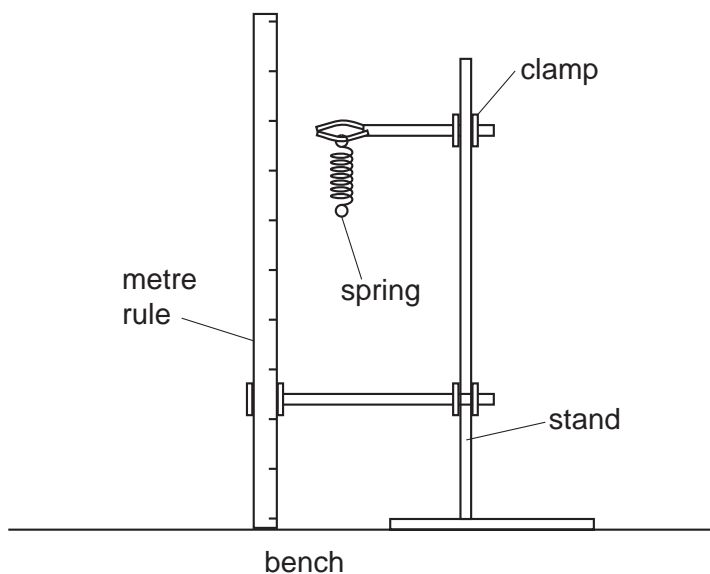

Fig. 2.1

Determine the extension e_1 of the spring when the 500 g mass is suspended from the spring. Record your answer on page 4 of your Answer Booklet. Describe with the aid of a diagram how the extension e_1 was determined. [3]

- (b) By carefully raising the beaker under the mass, determine the new extension e_2 of the spring when the 500 g mass is completely under water. The mass must not be touching the sides or base of the beaker. [1]

- (c) Determine the density ρ of the material from which the mass is made, given that

$$\rho = \frac{e_1}{e_1 - e_2} \times 1.00 \text{ g/cm}^3.$$

[1]

- 3** *In this experiment you will make some measurements on an electrical circuit that contains various combinations of resistors.*

You have been provided with a resistor labelled X, a resistor labelled Y, a power supply, a switch, an ammeter, a voltmeter and some connecting leads.

- (a)** The Supervisor has set up a circuit with a resistor X connected into the circuit. Close the switch and record the current I in the circuit and the potential difference V across the resistor X. Record your readings on page 5 of your Answer Booklet. Open the switch. [1]
- (b)** Repeat the experiment using the resistor Y instead of the resistor X. Record your readings of I and V . [1]
- (c)** State and explain which resistor has the higher resistance. [1]
- (d)** **(i)** Connect X and Y in parallel and repeat the experiment. Record your readings of I and V .
(ii) Comment on the results you have obtained in comparison to your results from parts **(a)** and **(b)**. [2]

Section B

4 *In this experiment you will investigate the rate of fall of temperature of a beaker of hot water.*

You have been provided with a 250 cm³ beaker, a thermometer held in a clamp and stand, a plastic stirrer, a supply of hot water, a measuring cylinder and a stopwatch.

- (a) There is a table on page 6 of your Answer Booklet that you will use to record readings of temperature θ and time t . Give appropriate headings and units for this table. [1]
- (b) Obtain water from the hot water supply and place sufficient water in the beaker so that the bulb of the thermometer is **just** covered. Observe the thermometer and you will see that the temperature rises initially. As soon as the temperature starts to fall, record the temperature and start the stopwatch. Continue to record the temperature at suitable intervals of time for a period of five minutes. Record all your results in the table on page 6 of your Answer Booklet. [3]
- (c) Using the grid on page 7 of your Answer Booklet, plot a graph of temperature on the y -axis against time on the x -axis. [4]
- (d) Draw the best-fit smooth curve through your plots. Draw a tangent to the curve to find the gradient G of the curve at a time of 150 seconds. [4]
- (e) Lift the thermometer out of the beaker. Use the measuring cylinder to measure the volume V of water that you have used in your experiment. Record V on page 8 of your Answer Booklet. [1]
- (f) State **two** precautions that you have taken in this experiment to ensure that your results are as accurate as possible. [2]

BLANK PAGE

BLANK PAGE

BLANK PAGE

Permission to reproduce items where third-party owned material protected by copyright is included has been sought and cleared where possible. Every reasonable effort has been made by the publisher (UCLES) to trace copyright holders, but if any items requiring clearance have unwittingly been included, the publisher will be pleased to make amends at the earliest possible opportunity.

University of Cambridge International Examinations is part of the University of Cambridge Local Examinations Syndicate (UCLES), which is itself a department of the University of Cambridge.