



Cambridge International Examinations
Cambridge Ordinary Level

PHYSICS

5054/12

Paper 1 Multiple Choice

May/June 2016

1 hour

Additional Materials: Multiple Choice Answer Sheet
 Soft clean eraser
 Soft pencil (type B or HB is recommended)

* 7 5 0 2 9 4 7 6 2 9 *

READ THESE INSTRUCTIONS FIRST

Write in soft pencil.

Do not use staples, paper clips, glue or correction fluid.

Write your name, Centre number and candidate number on the Answer Sheet in the spaces provided unless this has been done for you.

DO NOT WRITE IN ANY BARCODES.

There are **forty** questions on this paper. Answer **all** questions. For each question there are four possible answers **A, B, C** and **D**.

Choose the **one** you consider correct and record your choice in **soft pencil** on the separate Answer Sheet.

Read the instructions on the Answer Sheet very carefully.

Each correct answer will score one mark. A mark will not be deducted for a wrong answer.

Any rough working should be done in this booklet.

Electronic calculators may be used.

This document consists of **16** printed pages.

- 1 A student determines the circumference of a golf ball.

Which instrument gives a reading that is the circumference of the golf ball?

- A calipers
- B micrometer
- C rule
- D tape

- 2 A man pulls a sledge of mass 25 kg across level ground with a horizontal force of 60 N. A constant force of friction of 20 N acts on the sledge.

What is the acceleration of the sledge?

- A 0.63 m/s^2 B 1.6 m/s^2 C 2.4 m/s^2 D 3.2 m/s^2

- 3 A car moves in a circle at constant speed.

What is the direction of the resultant force acting on the car?

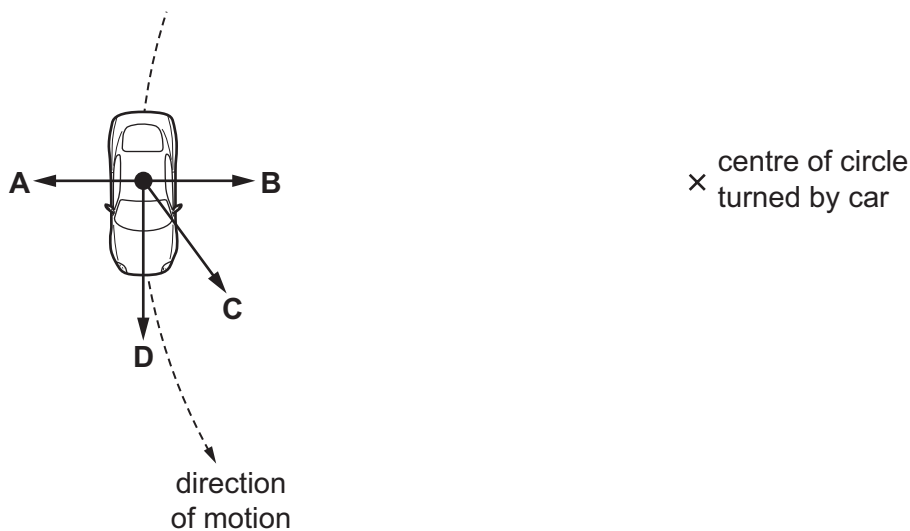

- 4 Which property of a body resists change from a state of rest or of motion?

- A density
- B mass
- C volume
- D weight

- 5 A brick is placed on a newton meter and then on a beam balance.

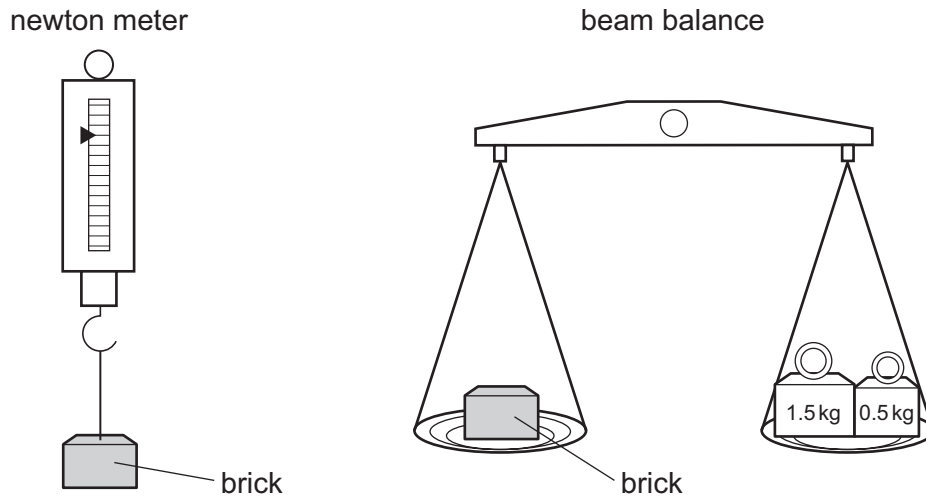

What is measured by each instrument?

	newton meter	beam balance
A	mass	mass
B	mass	weight
C	weight	mass
D	weight	weight

- 6 A uniform plank is pivoted at its mid-point. Two weights are added to the plank, one weight on each side of the pivot in the positions shown.

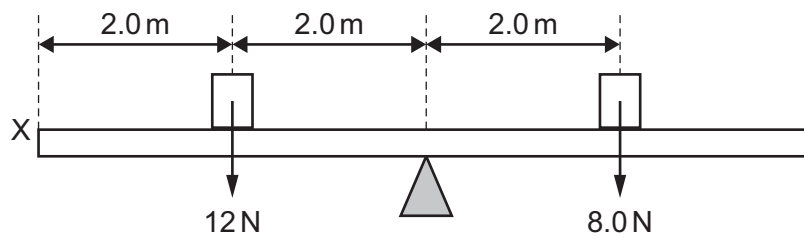

A vertical force is applied at point X to balance the plank.

What is the size and direction of this force?

	size / N	direction
A	2.0	downwards
B	2.0	upwards
C	4.0	downwards
D	4.0	upwards

7 Which quantity is a vector?

- A energy
- B force
- C speed
- D time

8 Which process in the Sun produces energy?

- A burning
- B nuclear fission
- C nuclear fusion
- D radiation

9 A 300 N force is applied to a box to move it up a ramp, as shown.

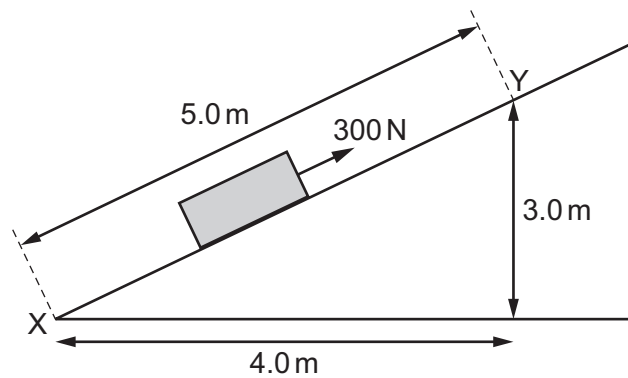

How much work is done by the force when moving the box from X to Y?

- A 900 J
- B 1200 J
- C 1500 J
- D 3000 J

10 Four beakers contain the same liquid.

At which point is the pressure the greatest?

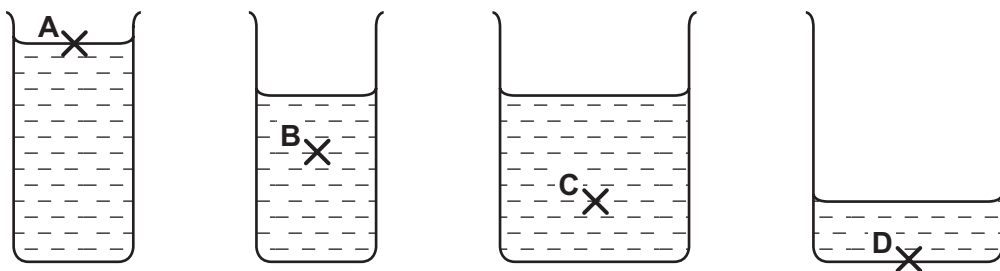

- 11 A block of weight W rests on a side of area A . The gravitational field strength is g .

What is the pressure exerted on the ground due to the block?

- A WA B $\frac{W}{A}$ C $\frac{WA}{g}$ D $\frac{W}{g}$

- 12 Water of depth 10 m exerts a pressure equal to atmospheric pressure.

An air bubble rises to the surface of a lake which is 20 m deep. When the bubble reaches the surface, its volume is 6.0 cm^3 .

What is the volume of the air bubble at the bottom of the lake?

- A 2.0 cm^3 B 3.0 cm^3 C 12 cm^3 D 18 cm^3

- 13 A gas in a container of fixed volume is heated.

What happens to the molecules of the gas?

- A They collide less frequently.
 B They expand.
 C They move faster.
 D They move further apart.

- 14 The diagram shows two liquid-in-glass thermometers P and Q.

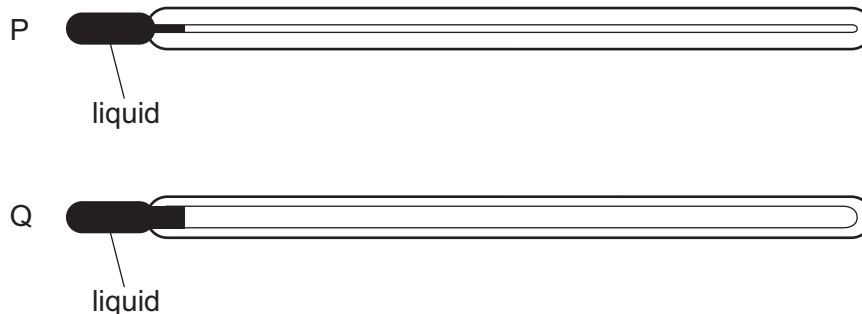

The thermometers are identical except that Q has a capillary tube with a larger internal diameter than P.

Which thermometer has the larger range and which thermometer has the greater sensitivity?

	larger range	greater sensitivity
A	P	P
B	P	Q
C	Q	P
D	Q	Q

- 15 A slice of bread is placed under a red-hot electric grill to make toast.

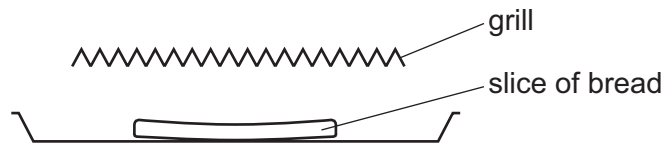

How does heat energy reach the bread?

- A conduction and convection
 - B conduction only
 - C convection and radiation
 - D radiation only
- 16 The diagram shows the inside of a refrigerator.

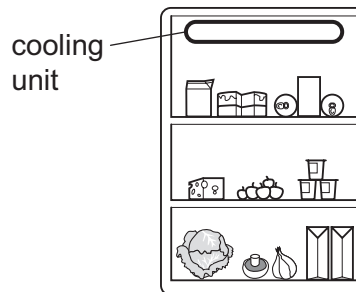

When the refrigerator is first switched on, what happens to the air near the cooling unit?

	the particles of this air	the density of this air
A	become smaller	decreases
B	become smaller	increases
C	move closer together	decreases
D	move closer together	increases

- 17 A water wave in a ripple tank refracts as it passes from deep water to shallow water.

Which properties change as the wave refracts?

- A frequency and amplitude
- B frequency and wavelength
- C speed and frequency
- D speed and wavelength

18 The diagram shows light incident on a plane mirror.

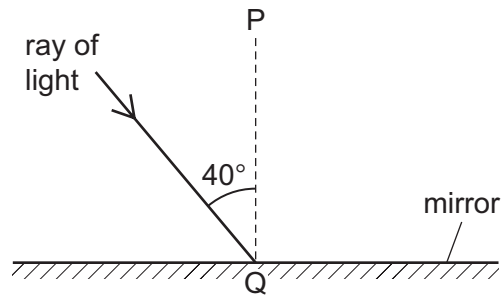

Which row gives the angle of reflection and the name of line PQ?

	angle of reflection	the line PQ is called the
A	40°	normal
B	40°	reflected ray
C	50°	normal
D	50°	reflected ray

19 Which length is the focal length of the lens shown in the diagram?

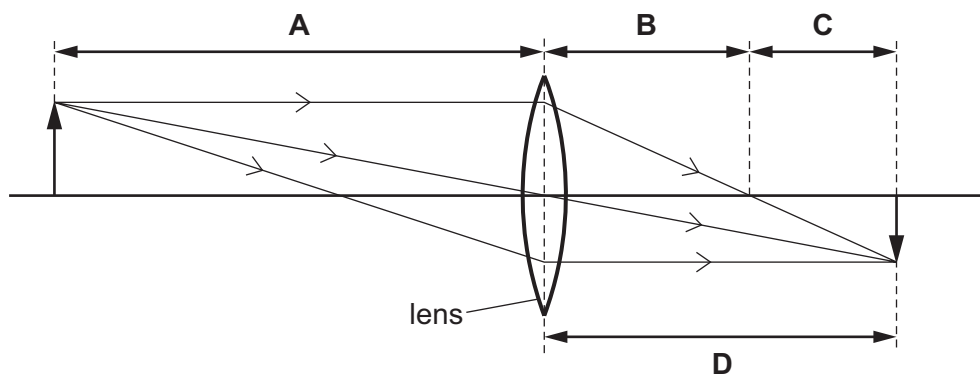

20 The rays of light from a ray-box pass through three lenses placed at positions 1, 2 and 3.

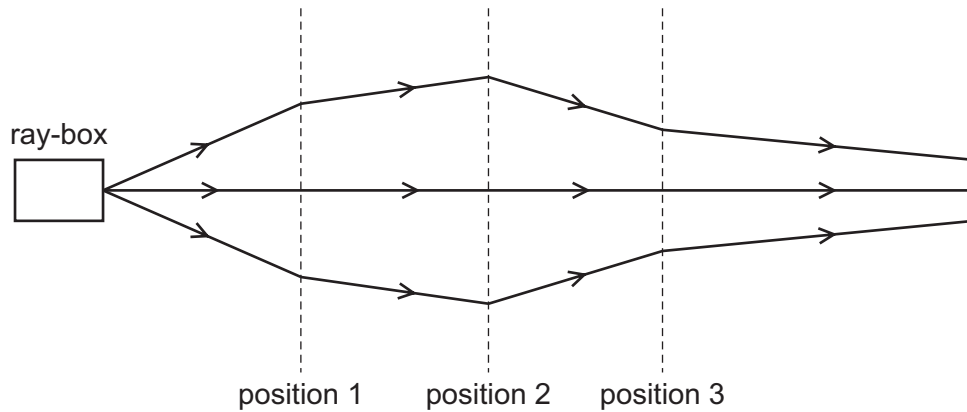

What type of lens is used at each position?

	position 1	position 2	position 3
A	converging	converging	converging
B	converging	converging	diverging
C	diverging	converging	diverging
D	diverging	diverging	converging

21 Light passes from air into a block of glass, as shown.

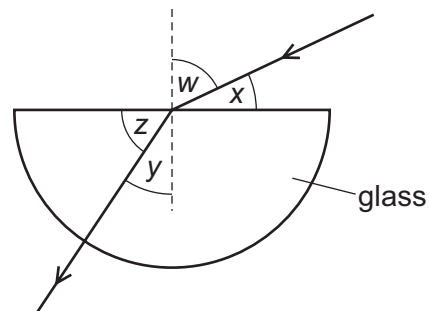

Which expression is equal to the refractive index of glass?

A $\frac{\sin w}{\sin y}$

B $\frac{\sin w}{\sin z}$

C $\frac{\sin y}{\sin w}$

D $\frac{\sin z}{\sin x}$

- 22 A sound wave travels through air. The lines in the diagram show the positions of layers of air at one particular time.

Which distance shows the wavelength of the wave?

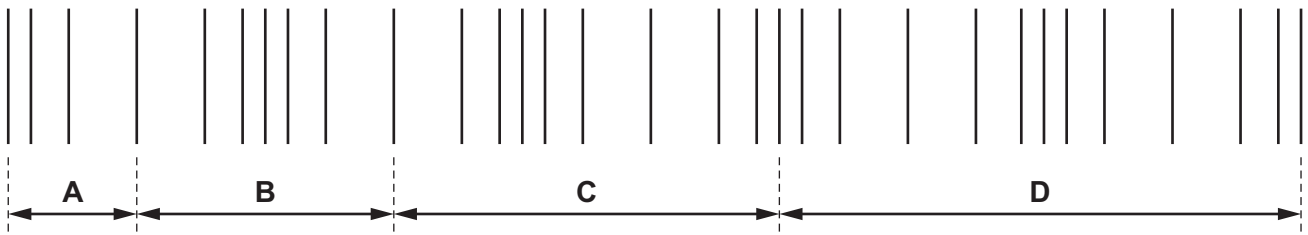

- 23 Four plotting compasses are placed near a bar magnet. You may ignore any effects of the Earth's magnetic field.

One compass appears like this .

What is a possible position for this compass?

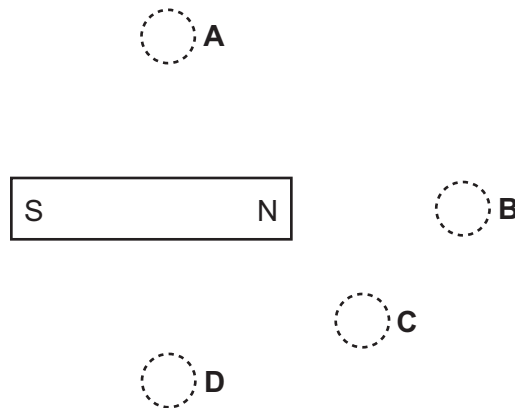

- 24 A polythene rod is rubbed with a cloth and the cloth becomes positively charged.

Which statement describes the transfer of charge?

- A Negative charges are transferred from the cloth to the polythene.
- B Negative charges are transferred from the polythene to the cloth.
- C Positive charges are transferred from the cloth to the polythene.
- D Positive charges are transferred from the polythene to the cloth.

- 25 A charge of 45 C flows through an electric appliance in 3.0 minutes.

What is the average current in the appliance?

- A 0.25 A
- B 4.0 A
- C 15 A
- D 135 A

26 How can *one volt* also be expressed?

- A one coulomb per ampere
- B one coulomb per joule
- C one joule per ampere
- D one joule per coulomb

27 The diagram shows a battery of three 1.5V cells.

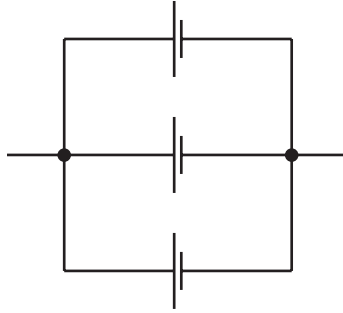

What is an advantage of this arrangement of cells?

- A The battery can supply a current for a longer time than a single 1.5V cell.
- B The battery can supply any e.m.f. between 0V and 4.5V.
- C The battery supplies more energy to each coulomb of charge than a single 1.5V cell.
- D The e.m.f. of the battery is 4.5V.

28 Which diagram shows the arrangement of the ammeter and voltmeter to obtain readings to find the power of a lamp?

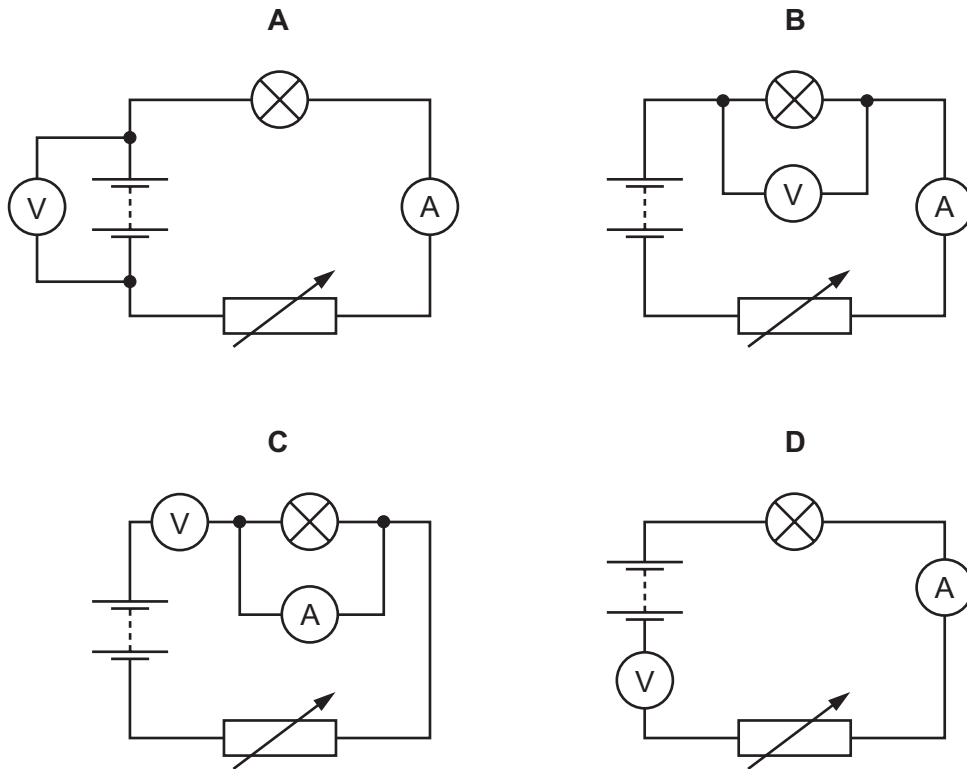

29 A 6.0V battery is connected to a network containing five identical resistors. A voltmeter has one lead connected to point K as shown.

At which point should lead L be connected so that the voltmeter reads 3.0V?

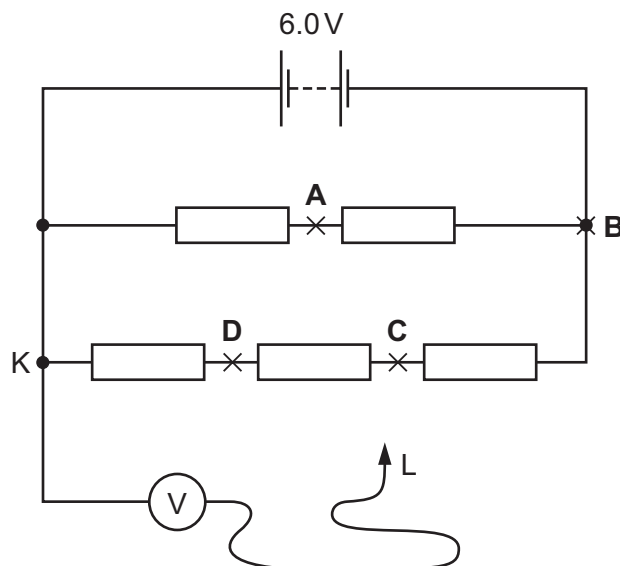

- 30 The diagram shows the wiring of a three-pin mains plug. There is an error in the diagram.

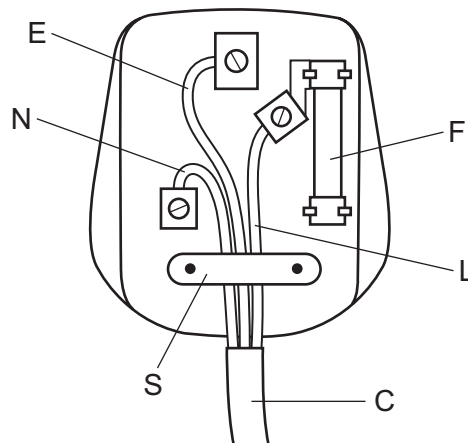

What is the error?

- A** The cable cover C is not under the clip S.
B The earth wire E is connected to the wrong terminal.
C The fuse F is connected to the live wire L.
D The live wire L is connected to the wrong end of the fuse F.
- 31 A 100W lamp is switched on for five hours each day for three weeks.

The cost of one unit of electricity is \$0.24.

How much does it cost to run the lamp for this time?

- A** \$0.36 **B** \$0.84 **C** \$2.52 **D** \$25.20

32 The diagram shows a simple d.c. motor.

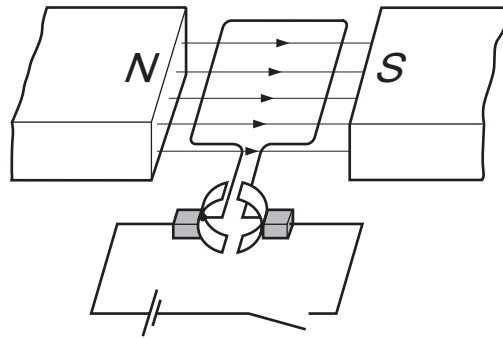

The switch is closed and the coil rotates.

Which change makes the coil rotate in the opposite direction **and** at a faster rate?

- A increase the current in the coil and increase the number of turns in the coil
 - B reverse both the magnetic field and the current in the coil
 - C reverse the magnetic field and decrease the current in the coil
 - D reverse the magnetic field and increase the current in the coil
- 33 The diagram shows a wire PQ between the N-pole and the S-pole of a magnet. There is a current in the wire in the direction of the arrow.

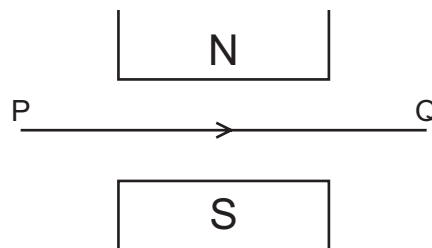

What is the direction of the force on the wire PQ?

- A into the page
- B out of the page
- C towards the N-pole
- D towards the S-pole

34 Electrical power is transmitted by cables over long distances at very high voltages.

What are the effects of using a high voltage transmission system?

	power loss in the cables	current in the cables
A	high	high
B	high	low
C	low	high
D	low	low

35 The diagram represents thermionic emission from a metal filament.

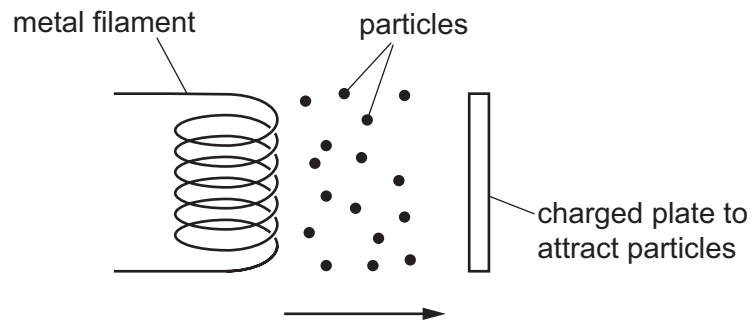

The particles are attracted by a charged plate.

Which row shows the charge on the plate, and the temperature of the metal filament?

	charge on plate	temperature of metal filament
A	negative	high
B	negative	low
C	positive	high
D	positive	low

- 36 A potential divider is connected across the terminals of a 6.0V supply.

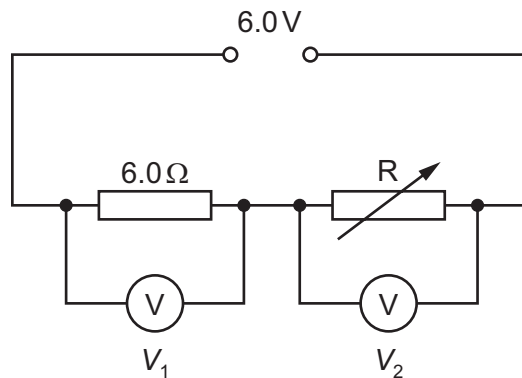

When R is adjusted to 6.0Ω, the voltmeter readings V₁ and V₂ are equal.

What happens to the readings when the resistance of R is then increased?

	V ₁	V ₂
A	decreases	decreases
B	decreases	increases
C	increases	decreases
D	increases	increases

- 37 Which nucleus is produced when americium-241 (${}_{95}^{241}\text{Am}$) emits an alpha-particle?

A ${}_{93}^{237}\text{Np}$ **B** ${}_{97}^{237}\text{Bk}$ **C** ${}_{93}^{245}\text{Np}$ **D** ${}_{97}^{245}\text{Bk}$

- 38 Which states the three types of radiation emitted by radioactive isotopes in order of their ionising effect from highest to lowest?

A alpha-particles, beta-particles, gamma-rays
B alpha-particles, gamma-rays, beta-particles
C beta-particles, gamma-rays, alpha-particles
D gamma-rays, beta-particles, alpha-particles

- 39 Which statement about the half-life of a radioactive isotope is correct?

A Half-life changes as the isotope decays.
B Half-life is the time it takes for the nucleon number of the isotope to halve.
C Half-life is half the time it takes for the number of nuclei of the isotope to decrease to zero.
D Half-life is the time it takes for the number of nuclei of the isotope to decrease by half.

40 The diagrams represent the nuclei of three atoms.

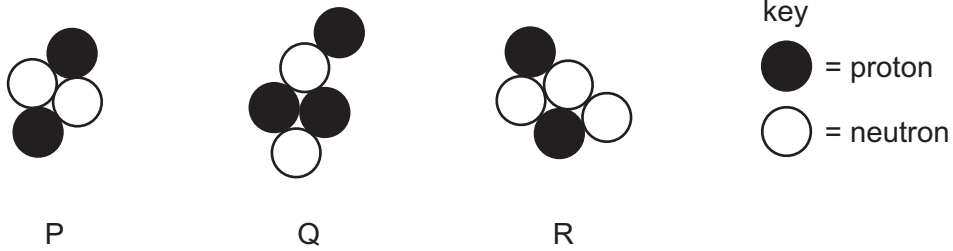

Which are isotopes of the same element?

- A P and Q only
- B P and R only
- C Q and R only
- D P, Q and R

Permission to reproduce items where third-party owned material protected by copyright is included has been sought and cleared where possible. Every reasonable effort has been made by the publisher (UCLES) to trace copyright holders, but if any items requiring clearance have unwittingly been included, the publisher will be pleased to make amends at the earliest possible opportunity.

To avoid the issue of disclosure of answer-related information to candidates, all copyright acknowledgements are reproduced online in the Cambridge International Examinations Copyright Acknowledgements Booklet. This is produced for each series of examinations and is freely available to download at www.cie.org.uk after the live examination series.

Cambridge International Examinations is part of the Cambridge Assessment Group. Cambridge Assessment is the brand name of University of Cambridge Local Examinations Syndicate (UCLES), which is itself a department of the University of Cambridge.