



Cambridge International Examinations
Cambridge International General Certificate of Secondary Education

PHYSICS

0625/23

Paper 2 Multiple Choice (Extended)

October/November 2016

45 minutes

Additional Materials: Multiple Choice Answer Sheet
Soft clean eraser
Soft pencil (type B or HB recommended)

* 5 6 4 9 0 3 0 7 2 1 *

READ THESE INSTRUCTIONS FIRST

Write in soft pencil.

Do not use staples, paper clips, glue or correction fluid.

Write your name, Centre number and candidate number on the Answer Sheet in the spaces provided unless this has been done for you.

DO NOT WRITE IN ANY BARCODES.

There are **forty** questions on this paper. Answer **all** questions. For each question there are four possible answers **A, B, C** and **D**.

Choose the **one** you consider correct and record your choice in **soft pencil** on the separate Answer Sheet.

Read the instructions on the Answer Sheet very carefully.

Each correct answer will score one mark. A mark will not be deducted for a wrong answer.

Any rough working should be done in this booklet.

Electronic calculators may be used.

Take the weight of 1.0 kg to be 10 N (acceleration of free fall = 10 m/s^2).

The syllabus is approved for use in England, Wales and Northern Ireland as a Cambridge International Level 1/Level 2 Certificate.

This document consists of **18** printed pages and **2** blank pages.

1 The graph shows how the distance travelled by a vehicle changes with time.

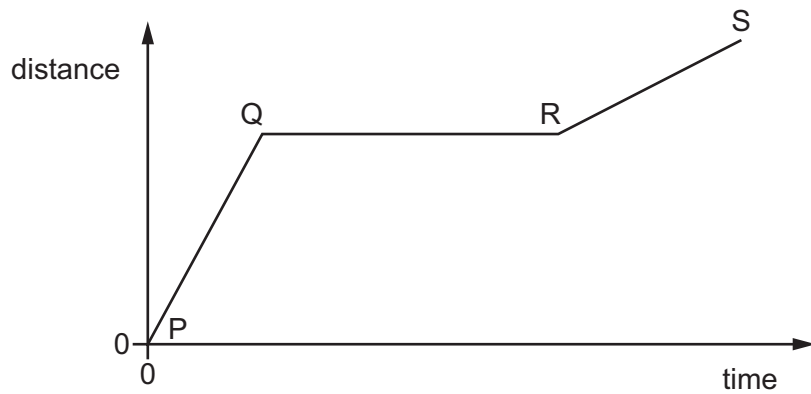

Which row describes the speed of the vehicle in each section of the graph?

	P to Q	Q to R	R to S
A	constant	zero	constant
B	constant	zero	decreasing
C	increasing	constant	decreasing
D	increasing	zero	constant

2 A stone falls freely from the top of a cliff. Air resistance may be ignored.

Which graph shows how the acceleration of the stone varies with time as it falls?

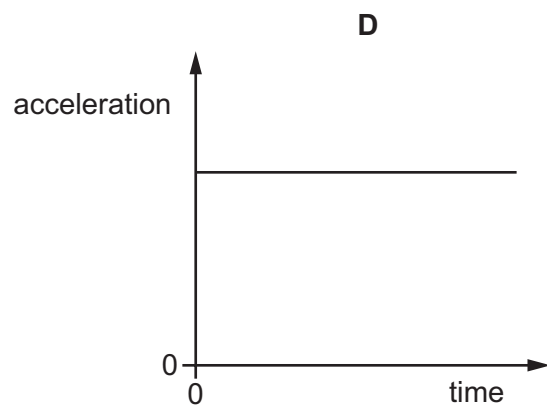
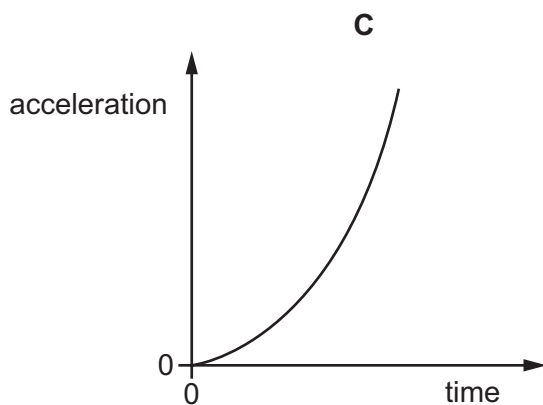
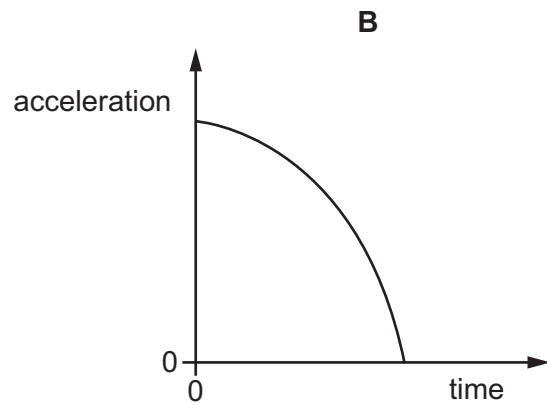
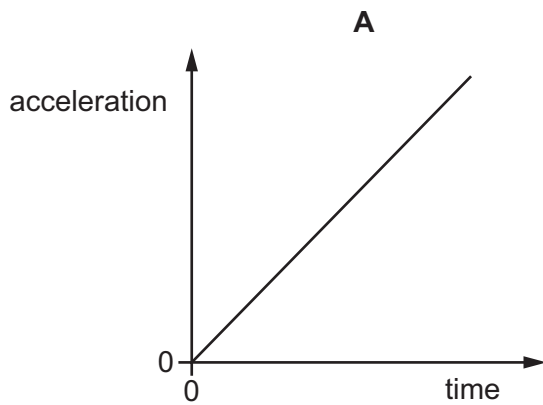

- 3 The speed-time graph for an object is shown.

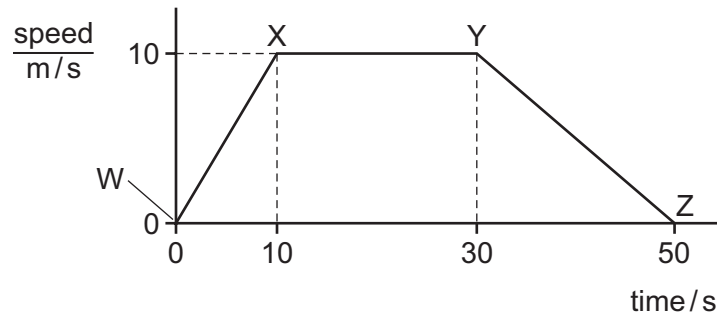

Below are four statements about the acceleration of the object.

Which statement is true?

- A** The acceleration in the first 10 s is $(10 \div 10) \text{ m/s}^2$.
- B** The acceleration increases between W and X.
- C** The acceleration decreases between Y and Z.
- D** The deceleration between Y and Z is $(10 \div 50) \text{ m/s}^2$.
- 4 An astronaut on the Moon weighs less than on Earth.

What is the reason for this difference, and how does his mass on the Moon compare with his mass on Earth?

	reason for weight difference	mass on Moon
A	the Moon has a weaker gravitational field	less than on Earth
B	the Moon has a weaker gravitational field	same as on Earth
C	the Moon has a weaker magnetic field	less than on Earth
D	the Moon has a weaker magnetic field	same as on Earth

- 5 The diagrams show an empty container, and the same container filled with liquid.

The empty container has a mass of 120 g. When filled with the liquid, the total mass of the container and the liquid is 600 g.



empty container
120 g

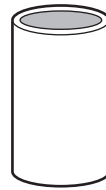

container filled with liquid
600 g

The volume of liquid in the container is 600 cm^3 .

What is the density of the liquid?

- A** 0.020 g/cm^3 **B** 0.80 g/cm^3 **C** 1.0 g/cm^3 **D** 1.2 g/cm^3
- 6 An object travels in a circular path at constant speed.

Which statement about the object is correct?

- A** It has changing kinetic energy.
B It has changing momentum.
C It has constant velocity.
D It is not accelerating.

- 7 Different loads are hung on a spring. The diagram shows the length of the spring with and without the loads attached.

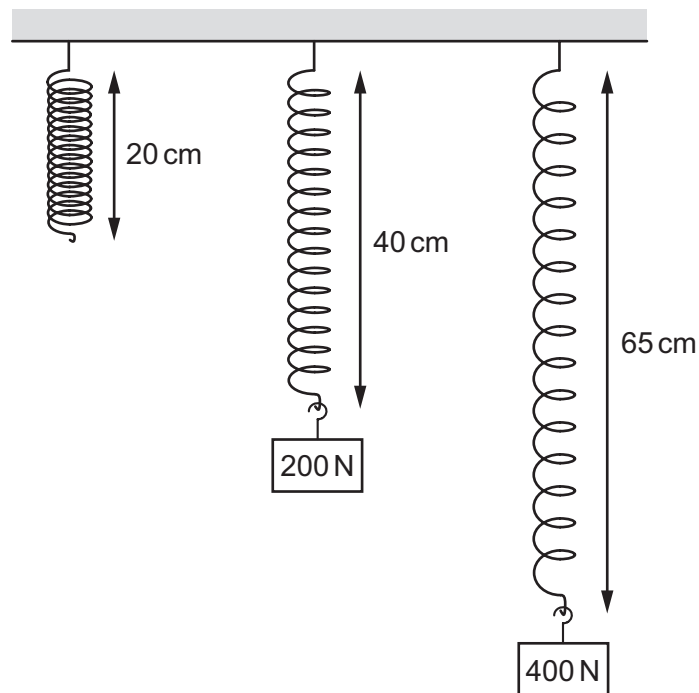

What is the extension of the spring when the load is 400 N?

- A** 5 cm **B** 25 cm **C** 40 cm **D** 45 cm
- 8 A vehicle of mass 900 kg is travelling with a velocity of 20 m/s.
- What is the momentum of the vehicle?
- A** 45 kg m/s **B** 450 kg m/s **C** 18 000 kg m/s **D** 180 000 kg m/s
- 9 Which list contains only scalar quantities?
- A** acceleration, energy, force, mass
- B** acceleration, force, momentum, velocity
- C** distance, energy, mass, speed
- D** distance, momentum, speed, velocity

10 A ball is dropped onto a floor.

Its speed just before hitting the floor is 3.0 m/s.

Which change would result in a speed of 6.0 m/s just before hitting the floor?

Ignore any effects due to air resistance.

- A Drop the ball from double the height above the floor.
- B Drop the ball from four times the height above the floor.
- C Use a ball with double the mass.
- D Use a ball with four times the mass.

11 Which list contains only energy resources that derive their energy from the Sun?

- A geothermal, nuclear, tidal
- B hydroelectric, water waves, wind
- C geothermal, hydroelectric, solar
- D nuclear, solar, water waves

12 A lamp has a power input of 5.0 W. It wastes 1.0 W of power heating the surroundings.

What is the efficiency of the lamp?

- A 20% B 50% C 80% D 120%

13 A container is filled with liquid to a certain depth h .

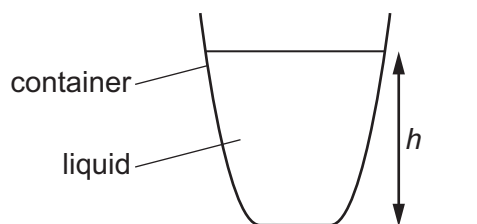

The pressure of the liquid at the bottom of the container depends on several factors.

Which is one factor on which the pressure does **not** depend?

- A the strength of the Earth's gravitational field
- B the density of the liquid
- C the depth of the liquid
- D the strength of the Earth's magnetic field

14 Which diagram best represents the movement of a smoke particle displaying Brownian motion?

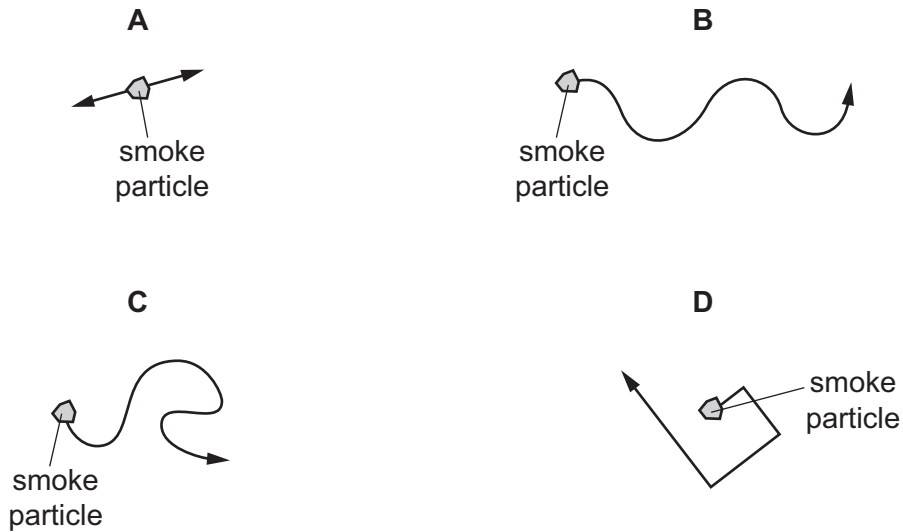

15 The volume of a gas is measured at different pressures.

The pressure p and the volume V of the gas are found to be related by the equation:

$$pV = \text{constant.}$$

Which quantities are kept constant and which quantities change?

	density of gas	mass of gas	temperature of gas
A	✓	✓	x
B	✓	x	✓
C	x	✓	✓
D	x	x	✓

key

✓ = constant

x = changed

- 16 A piece of melting ice at 0°C and a beaker of boiling water are both in a laboratory. The laboratory is at 20°C .

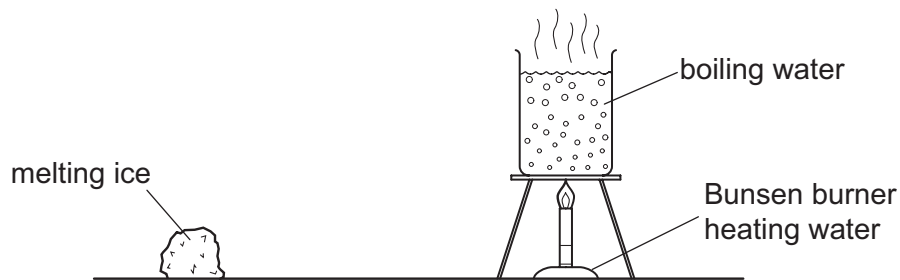

What is happening to the temperature of the melting ice and what is happening to the temperature of the boiling water?

	temperature of melting ice	temperature of boiling water
A	constant	constant
B	constant	increasing
C	increasing	constant
D	increasing	increasing

- 17 A scientist has two thermometers available: a liquid-in-glass thermometer and a thermocouple thermometer.

Which thermometer is better for measuring a very high temperature, and which thermometer is better for measuring a rapidly varying temperature?

	very high temperature	rapidly varying temperature
A	liquid-in-glass	liquid-in-glass
B	liquid-in-glass	thermocouple
C	thermocouple	liquid-in-glass
D	thermocouple	thermocouple

- 18 A copper container of mass 0.20 kg contains 0.10 kg of water.

The specific heat capacity of copper is $385 \text{ J}/(\text{kg } ^\circ\text{C})$ and the specific heat capacity of water is $4200 \text{ J}/(\text{kg } ^\circ\text{C})$.

How much energy, in joules, is needed to raise the temperature of the copper container and the water by 10°C ?

- A $(0.20 \times 385 \times 10) - (0.10 \times 4200 \times 10)$
 B $(0.20 \times 385 \times 10) + (0.10 \times 4200 \times 10)$
 C $(0.10 + 0.20) \times \left(\frac{4200 + 385}{2} \right) \times 10$
 D $(0.10 + 0.20) \times (4200 + 385) \times 10$
- 19 The diagrams show four spherical objects of the same size. Two of the objects are white and two are black. Two of the objects are at the same high temperature and two are at the same low temperature.

Which object emits infra-red radiation at the greatest rate?

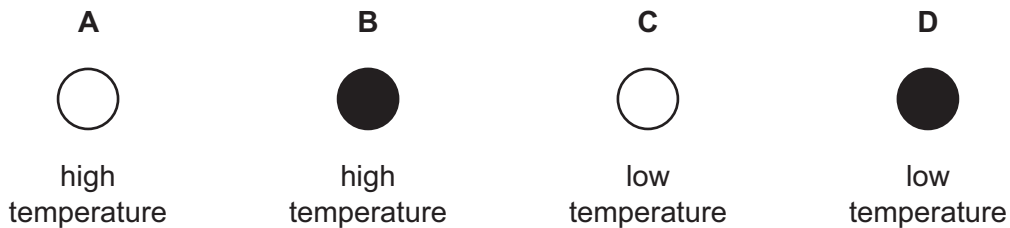

- 20 A man is talking at the side of a house. He can be heard by a woman at the front of the house even though she cannot see him.

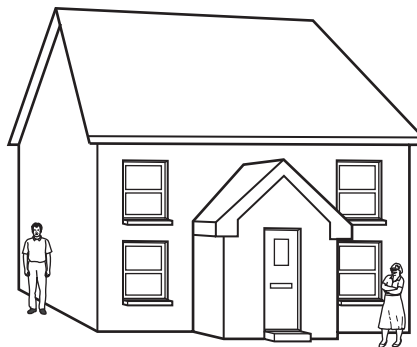

What is the explanation for this?

- A Sound waves are longitudinal and light waves are transverse.
 B Sound waves are transverse and light waves are longitudinal.
 C The sound waves have a long wavelength and the light waves have short wavelength.
 D The sound waves have a short wavelength and the light waves have long wavelength.

- 21 An image is formed by a plane mirror. A second image is formed by a lens used as a magnifying glass.

Which row states the nature of each of these images?

	plane mirror	magnifying glass
A	real	real
B	real	virtual
C	virtual	real
D	virtual	virtual

- 22 The speed of light in air is 3.0×10^8 m/s.

The critical angle for light in a transparent plastic material placed in air is 37° .

What is the speed of light in the plastic material?

- A** 1.8×10^8 m/s
 - B** 2.4×10^8 m/s
 - C** 3.8×10^8 m/s
 - D** 5.0×10^8 m/s
- 23 Which description applies to infra-red radiation?
- A** longitudinal and electromagnetic
 - B** longitudinal but not electromagnetic
 - C** transverse and electromagnetic
 - D** transverse but not electromagnetic
- 24 A girl notices that, when she shouts into a cave, she hears an echo.

Which wave property causes the echo?

- A** diffraction
- B** dispersion
- C** reflection
- D** refraction

- 25** A man stands 110m from a high wall. He makes a short, sharp sound and then hears an echo from the wall.

The speed of sound in air is 330 m/s.

How long after making the sound does the man hear the echo?

- A** 0.33s **B** 0.67s **C** 1.5s **D** 3.0s

- 26** A student suggests three methods for demagnetising a piece of steel.

- 1 placing it in an east-west direction and hammering it hard
- 2 placing it in an east-west direction and heating it until red hot
- 3 removing it slowly from a coil carrying alternating current

Which of the methods will demagnetise the piece of steel?

- A** 1 only **B** 2 only **C** 3 only **D** 1, 2 and 3

- 27** In two separate experiments, a magnet is brought near to an unmagnetised iron bar. This causes the bar to become magnetised.

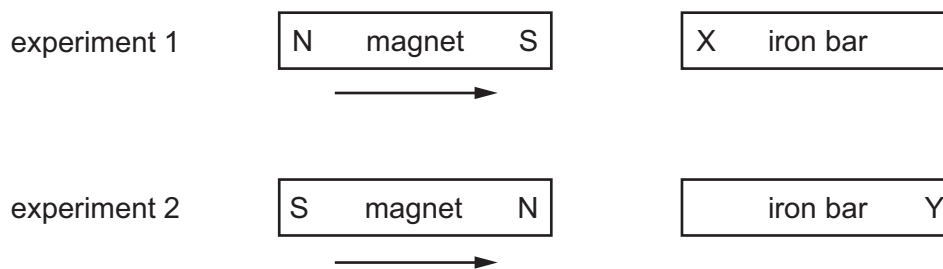

Which magnetic pole is induced at X and at Y?

	pole induced at X	pole induced at Y
A	N	N
B	N	S
C	S	N
D	S	S

28 A student holds a rod in his hand.

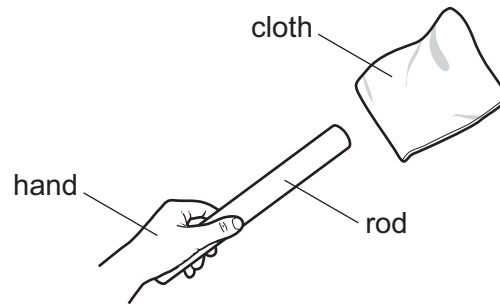

He rubs the rod with a cloth. The rod gains a positive charge.

Of which material could the rod be made, and which transfer of charge has happened?

	material of rod	transfer of charge
A	metal	negative charge from rod to cloth
B	metal	positive charge from cloth to rod
C	plastic	negative charge from rod to cloth
D	plastic	positive charge from cloth to rod

29 The diagram shows a lamp in a circuit.

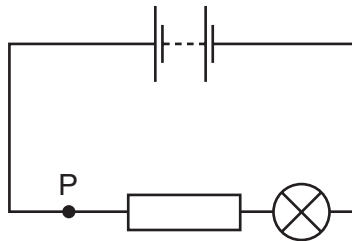

Which change to the circuit would increase the current in the lamp?

- A** adding another resistor in parallel with the one in the circuit
- B** adding another resistor in series with the one in the circuit
- C** decreasing the electromotive force (e.m.f.) of the battery in the circuit
- D** moving the lamp to point P in the circuit

- 30 The graph shows the relationship between the current in a circuit component and the potential difference (p.d.) across it. The graph has a straight section and a curved section.

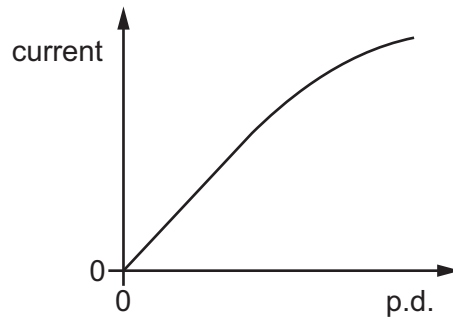

What happens to the resistance of the component in these two sections as the current increases?

	straight section	curved section
A	resistance increases	resistance decreases
B	resistance increases	resistance increases
C	no change in resistance	resistance decreases
D	no change in resistance	resistance increases

- 31 In the circuit shown there is a current of 10 A.

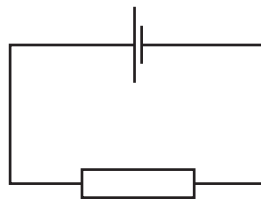

How much charge passes through the resistor in 2.0 minutes?

- A** 0.083 C **B** 5 C **C** 20 C **D** 1200 C

32 The four circuits shown each contain four diodes.

In which circuit is the direction of the current in the resistor always from the red terminal to the black terminal?

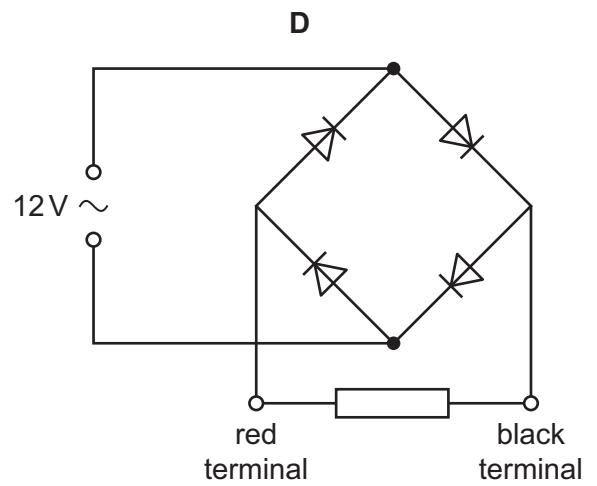
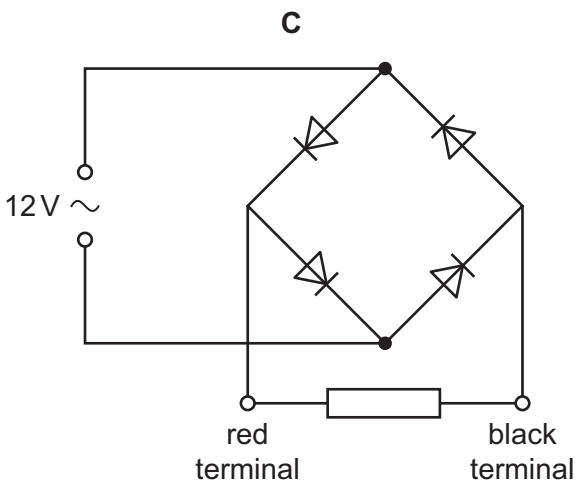
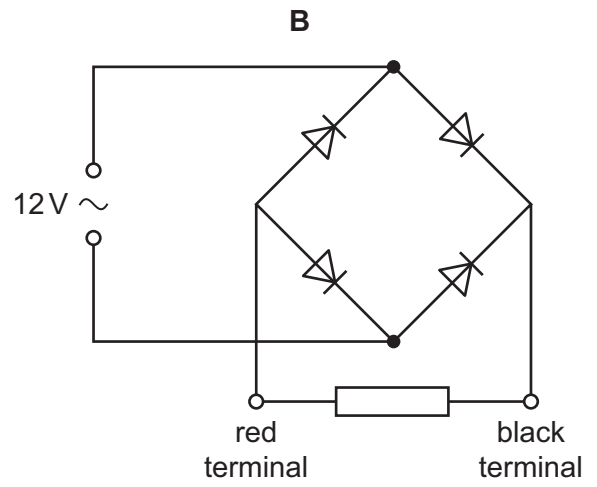
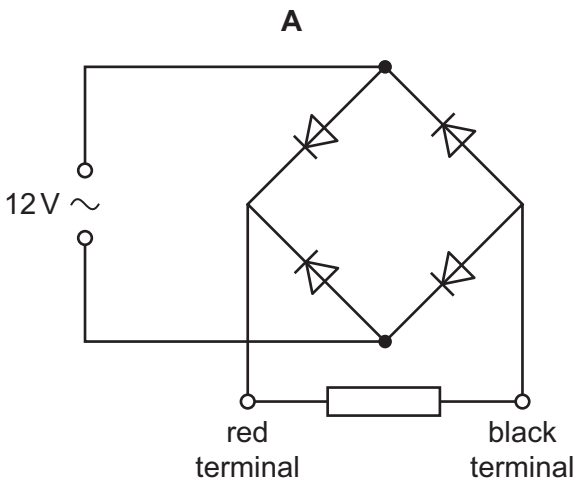

33 The diagram shows a potential divider.

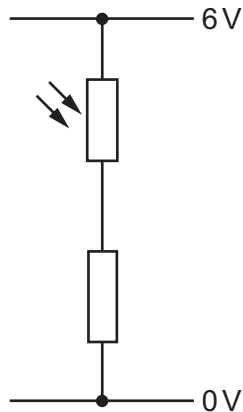

When brighter light falls on the light-dependent resistor (LDR), its resistance changes.

What happens to the resistance of the LDR and what happens to the current in it?

	resistance of LDR	current in LDR
A	decreases	decreases
B	decreases	increases
C	increases	decreases
D	increases	increases

34 The diagram shows two logic gates connected together.

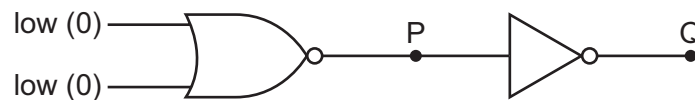

The two inputs are both low (0).

What are the logic states at P and at Q?

	P	Q
A	high (1)	high (1)
B	high (1)	low (0)
C	low (0)	high (1)
D	low (0)	low (0)

35 Two electrical appliances are connected to the mains supply.

The cable connected to one appliance includes an earth wire.

The cable connected to the second appliance does **not** need an earth wire.

What is a reason for this difference?

- A** One appliance has a metal case, but the other appliance does not.
- B** One appliance is fitted with a fuse, but the other appliance is not.
- C** One appliance is fitted with a switch, but the other appliance is not.
- D** One appliance needs more current than the other appliance.

36 An electric current can produce a heating effect and a magnetic effect.

Which row shows the effect that a relay uses and one application of a relay?

	effect used by a relay	one application of a relay
A	heating effect	allowing a small current to switch on a large current
B	heating effect	changing the voltage of an a.c. supply
C	magnetic effect	allowing a small current to switch on a large current
D	magnetic effect	changing the voltage of an a.c. supply

37 Which particle is absorbed by a nucleus to cause nuclear fission?

- A** a neutron
- B** a proton
- C** an α -particle
- D** a β -particle

- 38 An α -particle enters a uniform magnetic field directed out of the page.

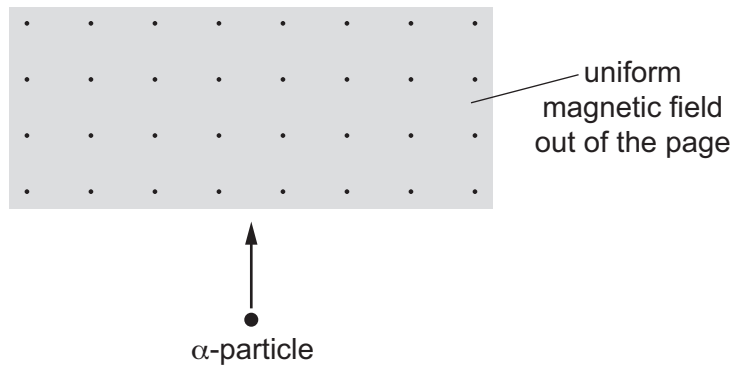

In which direction is the α -particle deflected by the field?

- A into the page
 - B out of the page
 - C to the left
 - D to the right
- 39 Radioactive source S emits α -particles, β -particles and γ -rays. A detector is placed 5 cm away from S. A thin sheet of paper is placed as shown in the diagram.

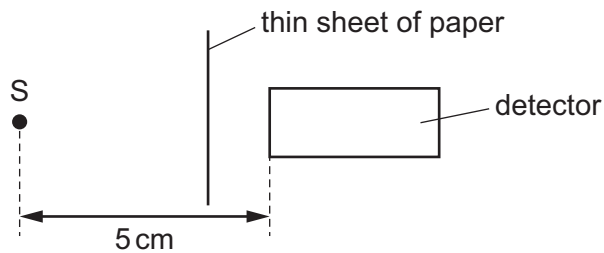

Which emissions from the source can be detected?

- A α -particles and β -particles only
- B α -particles and γ -rays only
- C β -particles and γ -rays only
- D α -particles, β -particles and γ -rays

40 Uranium-238 is radioactive and decays to thorium-234 by the emission of a particle.

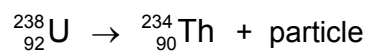

Which particle is emitted in this process?

- A an α -particle
- B a β -particle
- C a neutron
- D a proton

BLANK PAGE

BLANK PAGE

Permission to reproduce items where third-party owned material protected by copyright is included has been sought and cleared where possible. Every reasonable effort has been made by the publisher (UCLES) to trace copyright holders, but if any items requiring clearance have unwittingly been included, the publisher will be pleased to make amends at the earliest possible opportunity.

To avoid the issue of disclosure of answer-related information to candidates, all copyright acknowledgements are reproduced online in the Cambridge International Examinations Copyright Acknowledgements Booklet. This is produced for each series of examinations and is freely available to download at www.cie.org.uk after the live examination series.

Cambridge International Examinations is part of the Cambridge Assessment Group. Cambridge Assessment is the brand name of University of Cambridge Local Examinations Syndicate (UCLES), which is itself a department of the University of Cambridge.