



UNIVERSITY OF CAMBRIDGE INTERNATIONAL EXAMINATIONS
International General Certificate of Secondary Education

CANDIDATE
NAME

CENTRE
NUMBER

--	--	--	--	--

CANDIDATE
NUMBER

--	--	--	--



PHYSICS

0625/61

Paper 6 Alternative to Practical

October/November 2012

1 hour

Candidates answer on the Question Paper

No Additional Materials are required.

READ THESE INSTRUCTIONS FIRST

Write your Centre number, candidate number and name in the spaces at the top of the page.

Write in dark blue or black pen.

You may use a pencil for any diagrams or graphs.

Do not use staples, paper clips, highlighters, glue or correction fluid.

DO NOT WRITE IN ANY BARCODES.

Answer **all** questions.

At the end of the examination, fasten all your work securely together.

The number of marks is given in brackets [] at the end of each question or part question.

For Examiner's Use	
1	
2	
3	
4	
5	
Total	

This document consists of **11** printed pages and **1** blank page.



1 The IGCSE class is investigating the stretching of a spring.

Fig. 1.1 shows the experimental set up.

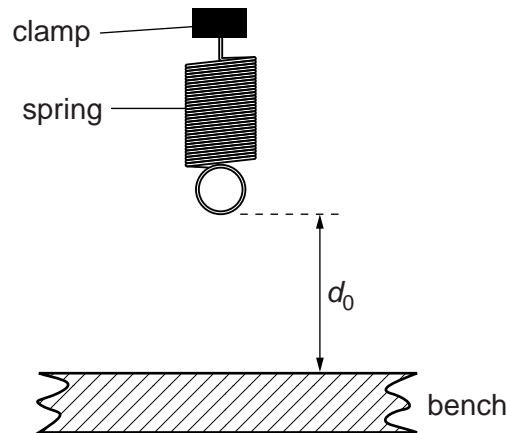

Fig. 1.1

(a) On Fig. 1.1, measure the vertical distance d_0 , in mm, between the bottom of the spring and the surface of the bench.

$d_0 = \dots\dots\dots$ mm [1]

(b) The diagram is drawn $1/10^{\text{th}}$ actual size. Calculate the actual distance D_0 , in mm, between the bottom of the spring and the surface of the bench.

$D_0 = \dots\dots\dots$ mm [1]

(c) A student hangs a 1.0N load on the spring. He measures and records the distance D between the bottom of the spring and the surface of the bench, and the value of the load L .

He repeats the procedure using loads of 2.0N, 3.0N, 4.0N and 5.0N. The distance readings are shown in Table 1.1.

Calculate the extension e of the spring, for each set of readings, using the equation $e = (D_0 - D)$. Record the values of L and e in Table 1.1.

Table 1.1

L/N	D/mm	e/mm
	199	
	191	
	179	
	171	
	160	

[2]

(d) Plot a graph of e/mm (y -axis) against L/N (x -axis).

For
Examiner's
Use

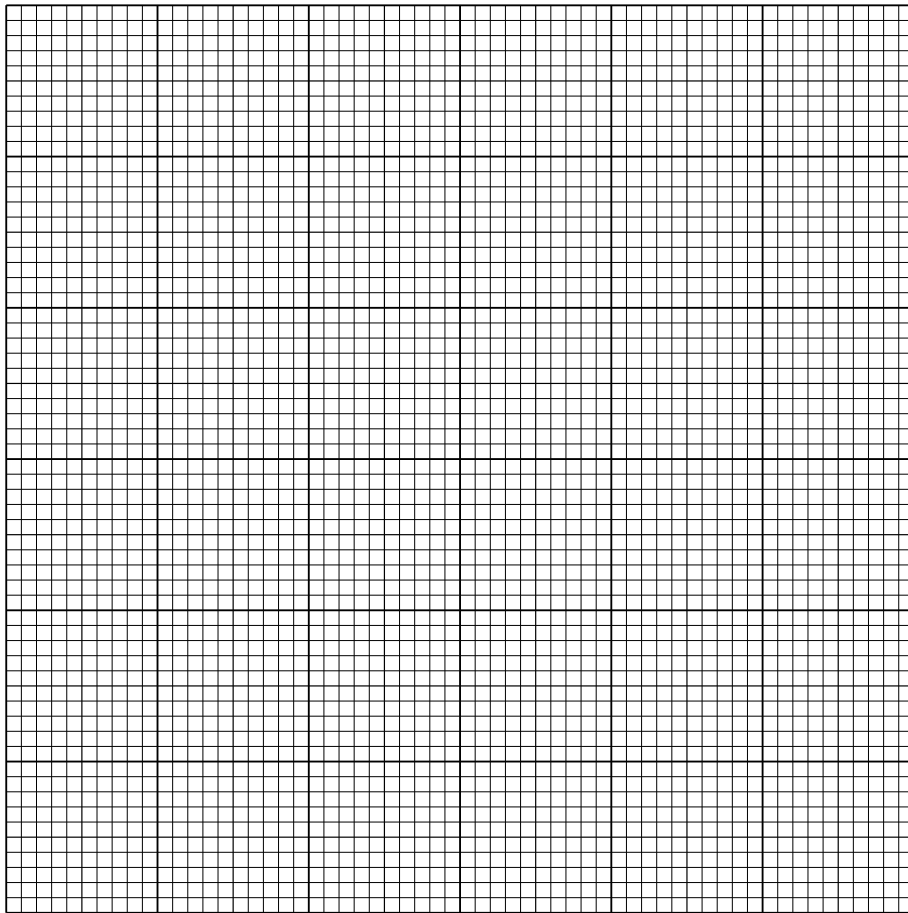

[4]

(e) Determine the gradient G of the graph. Show clearly on the graph how you obtained the necessary information.

$G = \dots\dots\dots$ [2]

(f) When making measurements, the student is careful to avoid a line-of-sight error.

Suggest one other precaution that the student should take when measuring the distance D between the bottom of the spring and the surface of the bench.

.....
..... [1]

[Total: 11]

2 The IGCSE class is investigating the rate of cooling of water under different conditions.

The apparatus is shown in Fig. 2.1.

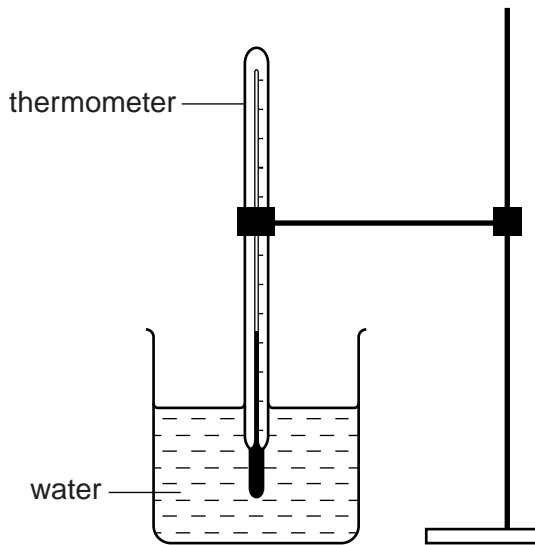

Fig. 2.1

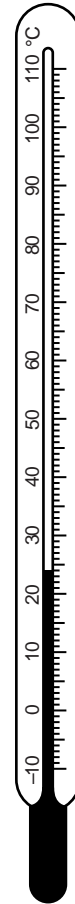

Fig. 2.2

(a) Record the value of room temperature θ_R shown on the thermometer in Fig. 2.2.

$\theta_R = \dots\dots\dots$ [1]

- (b) A student pours 150 cm^3 of hot water into a beaker. She measures the temperature θ of the water at time $t = 0$ and records it in a table.

She starts a stopclock and records the temperature of the water at 30s intervals until she has a total of six values up to time $t = 150$ s. The readings are shown in Table 2.1.

She repeats the procedure, using 250 cm^3 of hot water.

Table 2.1

	volume of water	
	150 cm^3	250 cm^3
$t/$	$\theta/$	$\theta/$
0	84	85
30	79	79
60	74	75
90	70	72
120	68	70
150	66	68

- (i) Complete the column headings in the table. [1]

- (ii) State whether the rate of cooling is significantly faster, slower, or about the same when using the larger volume of hot water. Justify your answer by reference to the readings.

statement

justification

.....
.....

[2]

- (c) If this experiment were to be repeated in order to check the results, it would be important to control the conditions. Suggest two such conditions that should be controlled.

1.

2.

[2]

[Total: 6]

- 3 The IGCSE class is investigating the potential differences across circuit components.

Fig. 3.1 shows the apparatus used.

For
Examiner's
Use

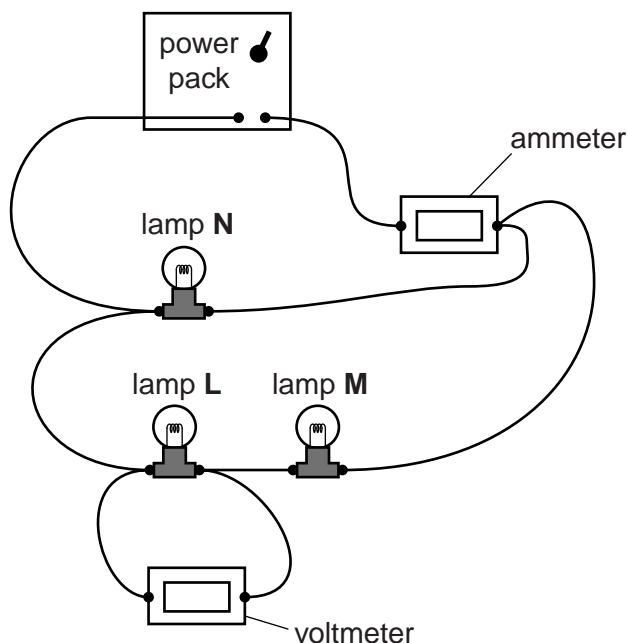

Fig. 3.1

- (a) Draw a circuit diagram of the circuit shown in Fig. 3.1, using standard symbols.

[3]

- (b) A student records the current I_A , the potential difference V_L across lamp **L** and the potential difference V_M across lamp **M**.

$$I_A = \dots\dots\dots 0.65 \text{ A} \dots\dots\dots$$

$$V_L = \dots\dots\dots 0.9 \text{ V} \dots\dots\dots$$

$$V_M = \dots\dots\dots 1.0 \text{ V} \dots\dots\dots$$

- (i) Calculate the potential difference V_A across lamps **L** and **M** using the equation $V_A = V_L + V_M$.

$$V_A = \dots\dots\dots$$

- (ii) Calculate R_A , the combined resistance of lamps **L**, **M** and **N**, using the equation

$$R_A = \frac{V_A}{I_A}$$

$$R_A = \dots\dots\dots [2]$$

- (iii) On Fig. 3.2, draw a pointer showing the current $I_A = 0.65\text{ A}$.

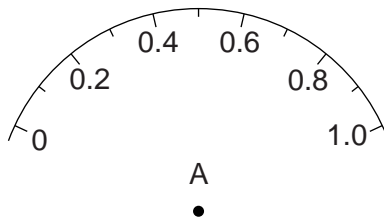

Fig. 3.2 [1]

- (c) The student rearranges the circuit so that the three lamps are in **series** with each other. He records the potential difference across each lamp in turn.

$$V_L = \dots\dots\dots 0.6\text{ V}$$

$$V_M = \dots\dots\dots 0.7\text{ V}$$

$$V_N = \dots\dots\dots 0.7\text{ V}$$

Calculate the potential difference V_B across the three lamps using the equation $V_B = V_L + V_M + V_N$.

$$V_B = \dots\dots\dots$$

- (d) A student suggests that V_A should be equal to V_B .

State whether the results support this suggestion and justify your answer with reference to the results.

statement

justification

.....

[2]

[Total: 8]

- 4 The IGCSE class is investigating the refraction of light passing through a transparent block. The apparatus and ray-trace sheet are shown in Fig. 4.1.

For
Examiner's
Use

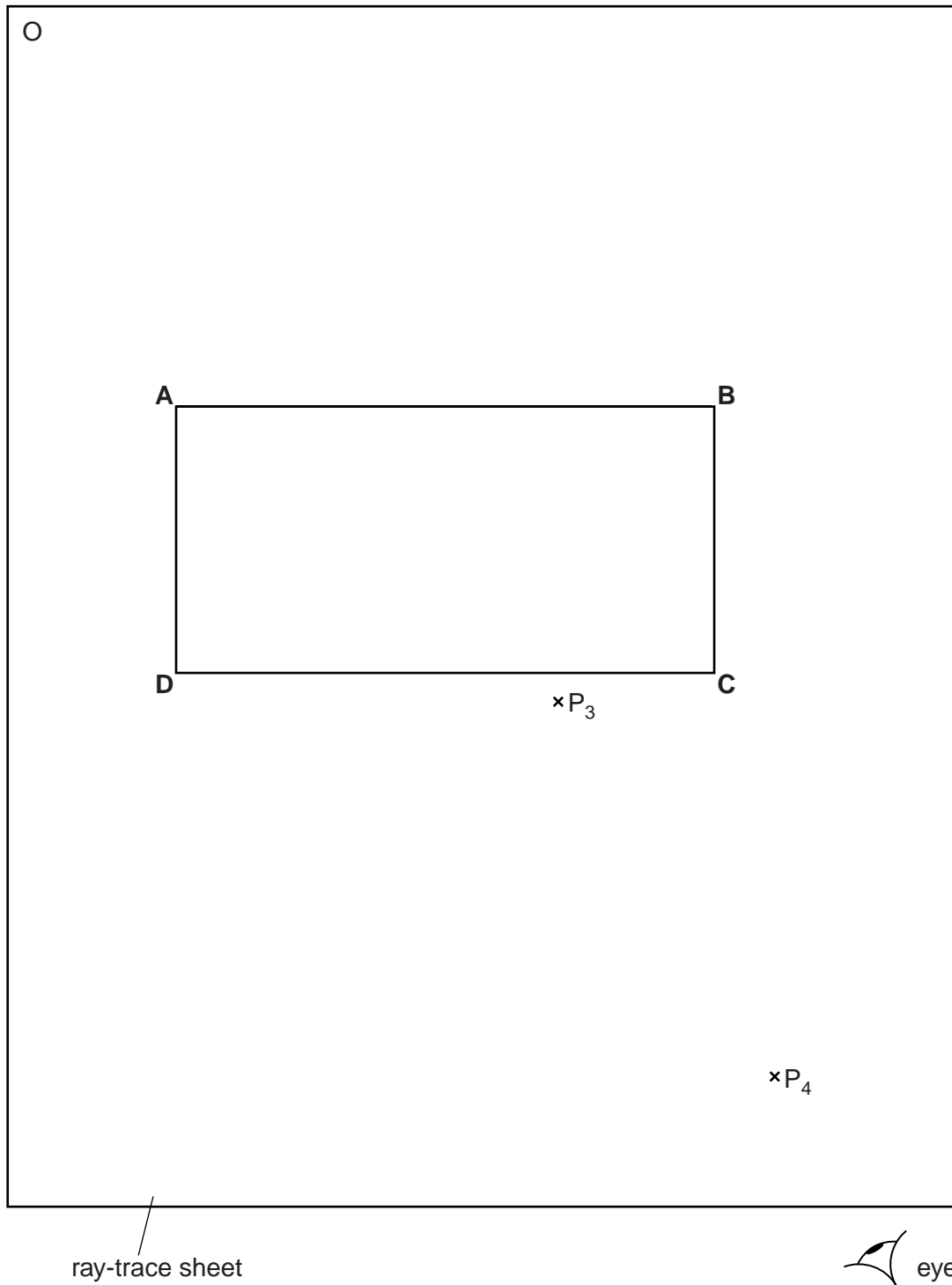

Fig. 4.1

(a) A student places the transparent block, largest face down, on the ray-trace sheet. She draws the outline of the block **ABCD**.

(i) On Fig. 4.1, draw a normal at the centre of side **AB**. Label the point **E** where the normal crosses **AB**.

(ii) Draw a line **FE** to the left of the normal and at an angle of incidence $i = 30^\circ$ to the normal. [2]

(b) The student places two pins P_1 and P_2 on the line **FE**, placing one pin close to **E**. She observes the images of P_1 and P_2 through side **CD** of the block so that the images of P_1 and P_2 appear one behind the other. She places two pins P_3 and P_4 between her eye and the block so that P_3 and P_4 , and the images of P_1 and P_2 seen through the block, appear one behind the other.

(i) On Fig. 4.1, mark suitable positions for the pins P_1 and P_2 . [1]

(ii) Draw a line joining the positions of P_3 and P_4 . Continue the line until it meets **CD** and label this point **G**.

(iii) Draw the line **GE**. [1]

(c) (i) Measure and record the angle of refraction r between the line **GE** and the normal.

$$r = \dots\dots\dots [1]$$

(ii) Calculate the ratio $\frac{i}{r}$.

$$\frac{i}{r} = \dots\dots\dots [1]$$

(d) The student repeats the procedure but with the angle of incidence $i = 40^\circ$. The angle of refraction $r = 26^\circ$.

(i) Calculate the ratio $\frac{i}{r}$.

$$\frac{i}{r} = \dots\dots\dots [1]$$

(ii) A student suggests that the ratio $\frac{i}{r}$ should be a constant.

State and explain briefly whether your results support this suggestion.

.....

.....

..... [1]

[Total: 8]

- 5 (a) The IGCSE class has a range of apparatus available. Here is a list of some of the apparatus.

For
Examiner's
Use

ammeter
barometer
beaker
electronic balance
manometer
measuring cylinder
metre rule
newtonmeter (spring balance)
stopwatch
tape measure
thermometer
voltmeter

Complete Table 5.1 by inserting the name of one piece of apparatus from the list that is the most suitable for measuring each quantity described.

Table 5.1

quantity to be measured	most suitable apparatus
volume of water	
a distance of about 50m	
the force required to lift a laboratory stool	
the mass of a coin	
the pressure of the laboratory gas supply	

[5]

- (b) The IGCSE class is carrying out a lens experiment. This involves using an illuminated object, a screen and a lens.

Firstly, the distance between the illuminated object and the lens is measured with a metre rule. Next, a clearly focused image is obtained on the screen.

- (i) Explain briefly how you would avoid a parallax (line-of-sight) error when using the metre rule.

.....
.....
..... [1]

- (ii) State a precaution that you would take to ensure that the image is well focused.

.....
.....
..... [1]

[Total: 7]

BLANK PAGE

Permission to reproduce items where third-party owned material protected by copyright is included has been sought and cleared where possible. Every reasonable effort has been made by the publisher (UCLES) to trace copyright holders, but if any items requiring clearance have unwittingly been included, the publisher will be pleased to make amends at the earliest possible opportunity.

University of Cambridge International Examinations is part of the Cambridge Assessment Group. Cambridge Assessment is the brand name of University of Cambridge Local Examinations Syndicate (UCLES), which is itself a department of the University of Cambridge.