



UNIVERSITY OF CAMBRIDGE INTERNATIONAL EXAMINATIONS
International General Certificate of Secondary Education

CANDIDATE
NAME

CENTRE
NUMBER

--	--	--	--	--

CANDIDATE
NUMBER

--	--	--	--

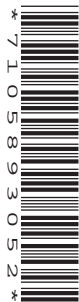

PHYSICS

0625/33

Paper 3 Extended

October/November 2011

1 hour 15 minutes

Candidates answer on the Question Paper.

No Additional Materials are required.

READ THESE INSTRUCTIONS FIRST

Write your Centre number, candidate number and name on all the work you hand in.

Write in dark blue or black pen.

You may use a pencil for any diagrams, graphs or rough working.

Do not use staples, paper clips, highlighters, glue or correction fluid.

DO **NOT** WRITE IN ANY BARCODES.

Answer **all** questions.

You may lose marks if you do not show your working or if you do not use appropriate units.

Take the weight of 1 kg to be 10 N (i.e. acceleration of free fall = 10 m/s^2).

At the end of the examination, fasten all your work securely together.

The number of marks is given in brackets [] at the end of each question or part question.

This document consists of **18** printed pages and **2** blank pages.



BLANK PAGE

1 An astronaut has a mass of 65 kg on Earth, where the gravitational field strength is 10 N/kg.

(a) Calculate the astronaut's weight on Earth.

weight on Earth = [2]

(b) Complete the following sentence.

The astronaut's weight on Earth is the force
between the astronaut and [1]

(c) The astronaut undertakes a Moon landing. On the Moon the gravitational field strength is 1.6 N/kg.

(i) State the astronaut's mass on the Moon.

mass =

(ii) Calculate the weight of the astronaut on the Moon.

weight on Moon = [2]

[Total: 5]

2 A person is standing on the top of a cliff, throwing stones into the sea below.

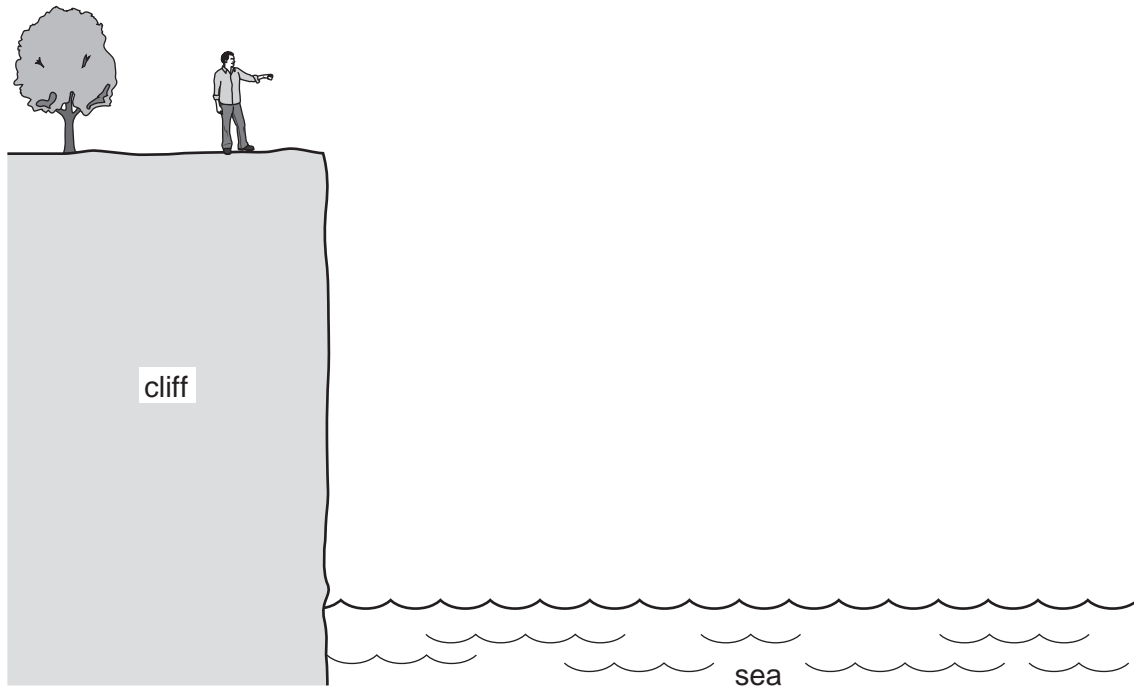

Fig. 2.1

(a) The person throws a stone horizontally.

(i) On Fig. 2.1, draw a line to show the path which the stone might take between leaving the person's hand and hitting the sea.

(ii) On the line you have drawn, at a point halfway to the sea, mark the stone and the direction of the force on the stone.

[3]

(b) Later, the person drops a small stone and a large stone vertically from the edge of the cliff.

Comment on the times taken for the two stones to hit the water.

.....

.....

.....

.....[2]

(c) 800 m from the point where the person is standing, a navy ship is having target practice.

The person finds that if a stone is dropped vertically at the same time as the spurt of smoke from the ship's gun is seen, the stone hits the water at the same time as the sound from the gun is heard.

Sound travels at 320 m/s in that region.

Calculate the velocity with which the stone hits the water.

velocity =[4]

[Total: 9]

3 (a) (i) State the difference between a scalar quantity and a vector quantity.

.....
.....

(ii) State one example of a vector quantity.

..... [2]

(b) Fig. 3.1 shows the top of a flagpole.

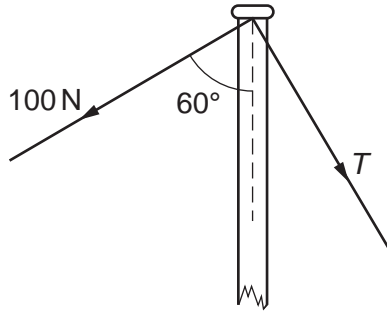

Fig. 3.1

The flagpole is held vertical by two ropes. The first of these ropes has a tension in it of 100 N and is at an angle of 60° to the flagpole. The other rope has a tension T , as shown.

The resultant force is down the pole and of magnitude 200 N.

In the space below, using a scale of $1\text{ cm} = 20\text{ N}$, draw a scale drawing to find the value of the tension T . Clearly label 100 N, 200 N and T on your drawing.

tension $T =$ [3]

[Total: 5]

4 A soldier wears boots, each having an area of 0.016 m^2 in contact with the ground.

The soldier weighs 720 N .

(a) (i) Write down the equation that is used to find the pressure exerted by the soldier on the ground.

(ii) Calculate the pressure exerted by the soldier when he is standing to attention, with both boots on the ground.

pressure =
[2]

(b) The soldier is crossing a sandy desert.

Explain, stating the relevant Physics, why this soldier is at an advantage over another soldier who has the same weight but smaller feet.

.....
.....
.....
.....[2]

(c) The soldier's unit is sent to a cold country, and on one occasion he has to cross a frozen lake.

Suggest one way that the soldier can reduce the risk of the ice breaking under his weight.

.....
.....
.....[1]

[Total: 5]

5 Two workmen are employed on a building project, as shown in Fig. 5.1.

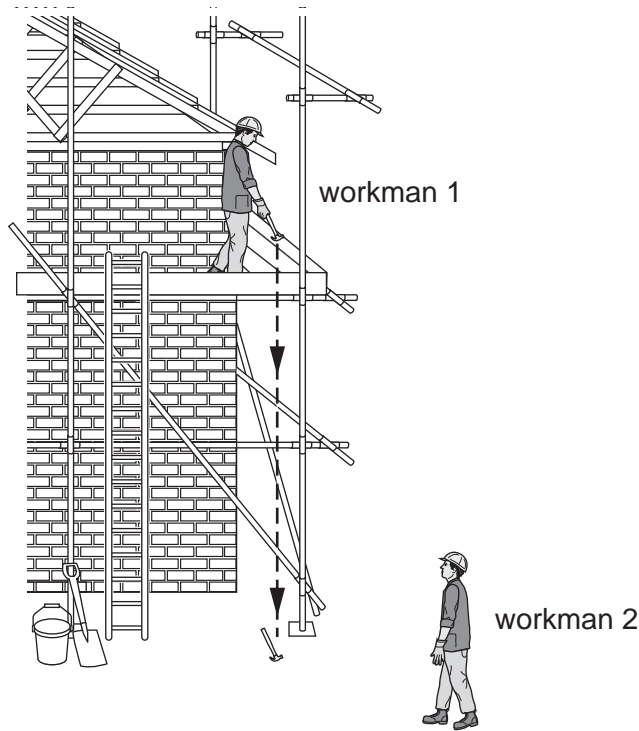

Fig. 5.1

- (a) Workman 1 drops a hammer, which falls to the ground. The hammer has a mass of 2.0kg, and is dropped from a height of 4.8m above the ground.
 - (i) Calculate the change in gravitational potential energy of the hammer when it is dropped.

change in gravitational potential energy =[2]

- (ii) Describe the energy changes from the time the hammer leaves the hand of workman 1 until it is at rest on the ground.

.....

.....

.....

.....[2]

(b) Workman 2 picks up the hammer and takes it back up the ladder to workman 1.

He climbs the first 3.0 m in 5.0 s. His total weight, including the hammer, is 520 N.

(i) Calculate the useful power which his legs are producing.

power =[2]

(ii) In fact his body is only 12% efficient when climbing the ladder.

Calculate the rate at which energy stored in his body is being used.

rate =[1]

[Total: 7]

- 6 (a) (i) In the space below, draw a labelled diagram of the apparatus you would use to measure the specific heat capacity of a liquid. If you choose an electrical method, you must include the circuit.

[3]

- (ii) List the quantities you would need to measure, or previously know, in order to calculate the specific heat capacity of the liquid.

.....
.....
.....
.....
.....[3]

- (b) Some sea water has a specific heat capacity of $3900 \text{ J}/(\text{kg}^\circ\text{C})$ and a boiling point of 100.6°C .

- (i) Calculate the energy required to raise the temperature of 0.800 kg of this sea water from 12.0°C up to its boiling point. State the equation that you use.

energy =[4]

(ii) The energy to raise the temperature in (b)(i) is supplied at the rate of 620 W.

Calculate the time taken to raise the sea water to its boiling point.

time =[2]

[Total: 12]

- 7 Fig. 7.1 shows a circuit containing a 12V power supply, some resistors and an ammeter whose resistance is so small that it may be ignored.

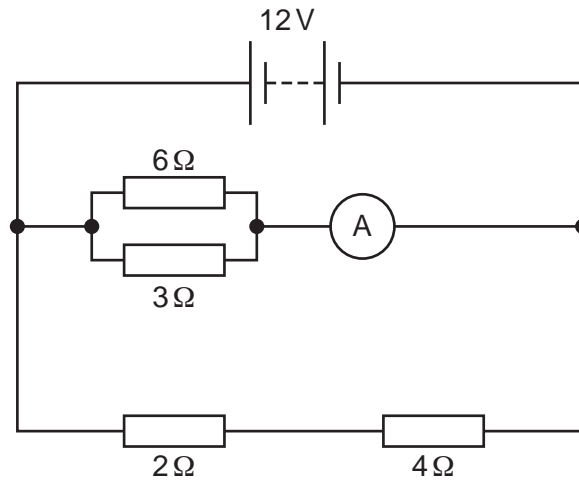

Fig. 7.1

- (a) (i) Determine the potential difference across the 2 Ω resistor.

potential difference =[1]

- (ii) State the potential difference across the 3 Ω resistor. [1]

- (b) Calculate the effective resistance of

- (i) the 2 Ω and 4 Ω resistors connected in series,

resistance =[1]

- (ii) the 3 Ω and 6 Ω resistors connected in parallel.

resistance =[2]

(c) Calculate the reading on the ammeter.

ammeter reading =[2]

(d) Without further calculation, state what happens, if anything, to the ammeter reading if

(i) the 2Ω resistor is shorted out with a thick piece of wire,

.....

(ii) the thick piece of wire from (d)(i) and the 3Ω resistor are both removed.

.....

[2]

[Total: 9]

- 8 Fig. 8.1 shows a simple motor with a rectangular coil that is free to rotate about an axis A_1A_2 . The coil is connected to a battery by brushes B_1 and B_2 .

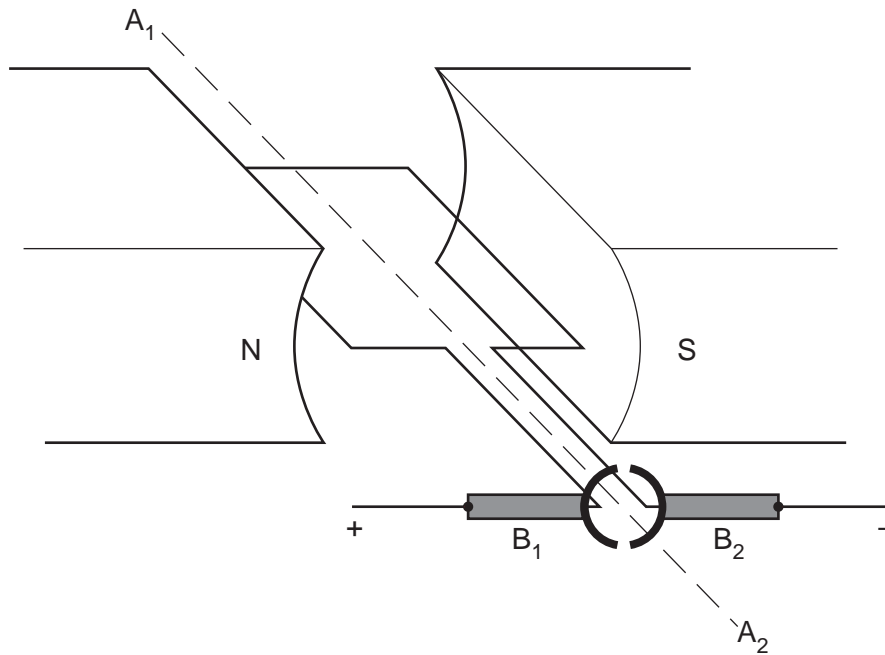

Fig. 8.1

- (a) Brush B_1 is connected to the positive terminal of the battery and brush B_2 is connected to the negative terminal of the battery.

(i) On Fig. 8.1, use an arrow to show the direction of the conventional current in the coil. [1]

(ii) State the direction in which the coil rotates, when viewed from the end closest to the brushes.

.....[1]

- (b) State what difference, if any, each of the following changes makes to the rotation of the coil:

(i) using a battery with a larger potential difference,

.....

(ii) using a coil with several turns of wire carrying the same current as in (a),

.....

(iii) using a stronger magnetic field.

.....

[3]

- (c) The structure of the motor is very similar to that of an a.c. generator. Use ideas about induction to suggest why the current from the battery falls as the motor speeds up.

.....
.....
.....[1]

[Total: 6]

9 Fig. 9.1 represents a ray of monochromatic light passing through a rectangular glass block.

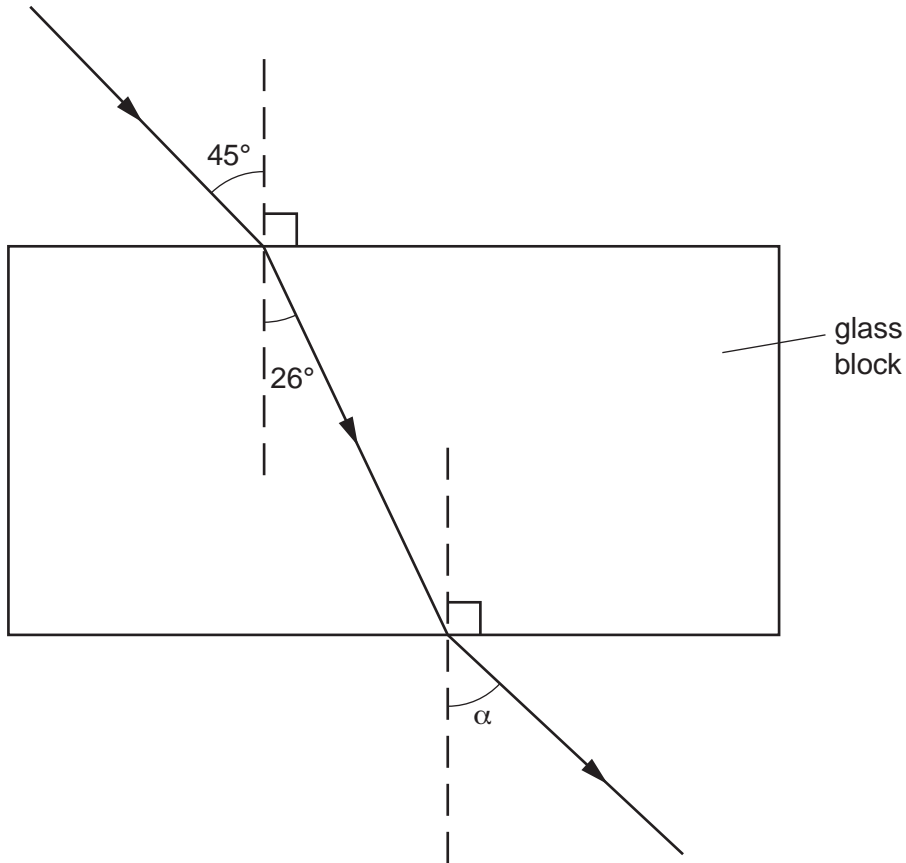

Fig. 9.1 (not to scale)

(a) What is meant by the term *monochromatic*?

.....
[1]

(b) Use the information on Fig. 9.1 to determine the refractive index of the glass.

refractive index =[2]

(c) The angle α on Fig. 9.1 is not drawn with the correct value.

State the correct value of angle α .

$\alpha =$ [1]

(d) After the ray has left the glass block, it passes into a block of ice, whose refractive index is 1.31.

How does the speed of light in ice compare with

(i) the speed of light in air,

(ii) the speed of light in glass.

[2]

[Total: 6]

10 Fig. 10.1 shows schematically a digital electronic circuit.

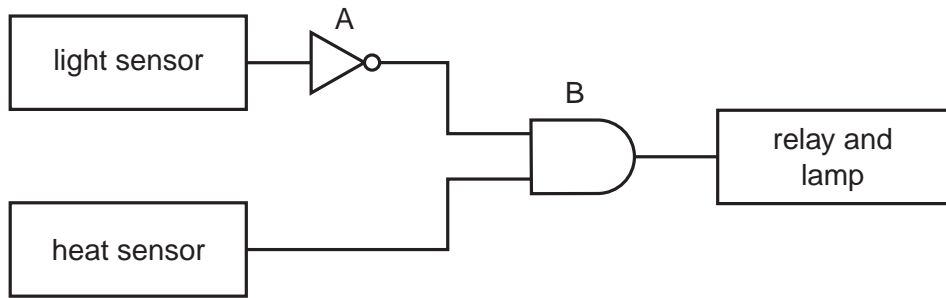

Fig. 10.1

(a) State the name of the logic gate

(i) at A,

(ii) at B.

[2]

(b) The light sensor has a “high” (logic 1) output in bright light and a “low” (logic 0) output when it is dark.

The heat sensor has a “high” (logic 1) output when it is hot and a “low” (logic 0) output when it is cold.

State the outputs of A and B when

(i) it is bright and cold,

output of A =

output of B =

(ii) it is dark and hot.

output of A =

output of B =

[4]

(c) Suggest why B is connected to a relay in order to light the lamp.

.....
.....[1]

(d) Suggest a practical use for this circuit.

.....
.....
.....[1]

[Total: 8]

- 11 (a) In a laboratory's secure radioactivity cupboard are two unlabelled radioactive sources. A scientist knows that one is an alpha-emitter and the other is a beta-emitter, but is not sure which is which.

A radiation detector, a magnet and some paper are available.

Briefly describe two different experimental tests, using this equipment, which would allow the scientist to identify which is the alpha-emitter and which is the beta-emitter.

test	outcome for alpha	outcome for beta

[4]

- (b) Radioactive carbon-14 ($^{14}_6\text{C}$) decays by emitting β -particles.

- (i) What are the values of the proton and nucleon numbers of carbon-14?

proton number

nucleon number [2]

- (ii) Carbon-14 is absorbed by living organisms. When the organism dies, no more carbon-14 is absorbed. The carbon-14 already absorbed decays with a half-life of 5730 years.

Recent human skeletons have an activity of 64 units, but a human skeleton dug up by an archaeologist has an activity of 8 units.

Determine the age of this ancient skeleton.

age = [2]

[Total: 8]

BLANK PAGE

Permission to reproduce items where third-party owned material protected by copyright is included has been sought and cleared where possible. Every reasonable effort has been made by the publisher (UCLES) to trace copyright holders, but if any items requiring clearance have unwittingly been included, the publisher will be pleased to make amends at the earliest possible opportunity.

University of Cambridge International Examinations is part of the Cambridge Assessment Group. Cambridge Assessment is the brand name of University of Cambridge Local Examinations Syndicate (UCLES), which is itself a department of the University of Cambridge.