

UNIVERSITY OF CAMBRIDGE INTERNATIONAL EXAMINATIONS
International General Certificate of Secondary Education

PHYSICS

Paper 3 Extended

**0625/03**

May/June 2006

1 hour 15 minutes

Candidates answer on the Question Paper.
No Additional Materials are required.

Candidate
Name
Centre
Number

--	--	--	--	--

Candidate
Number

--	--	--	--

READ THESE INSTRUCTIONS FIRST

Write your Centre number, candidate number and name on all the work you hand in.

Write in dark blue or black pen.

You may use a soft pencil for any diagrams, graphs or rough working.

Do not use staples, paper clips, highlighters, glue or correction fluid.

Answer **all** questions.

You may lose marks if you do not show your working or if you do not use appropriate units.

Take the weight of 1 kg to be 10 N (i.e. acceleration of free fall = 10 m/s²).

DO NOT WRITE IN THE BARCODE.

DO NOT WRITE IN THE GREY AREAS BETWEEN THE PAGES.

At the end of the examination, fasten all your work securely together.

The number of marks is given in brackets [] at the end of each question or part question.

For Examiner's Use	
1	
2	
3	
4	
5	
6	
7	
8	
9	
10	
11	
Total	

This document consists of **12** printed pages.



- 1 A bus travels from one bus stop to the next. The journey has three distinct parts. Stated in order they are
 uniform acceleration from rest for 8.0 s,
 uniform speed for 12 s,
 non-uniform deceleration for 5.0 s.

Fig. 1.1 shows only the deceleration of the bus.

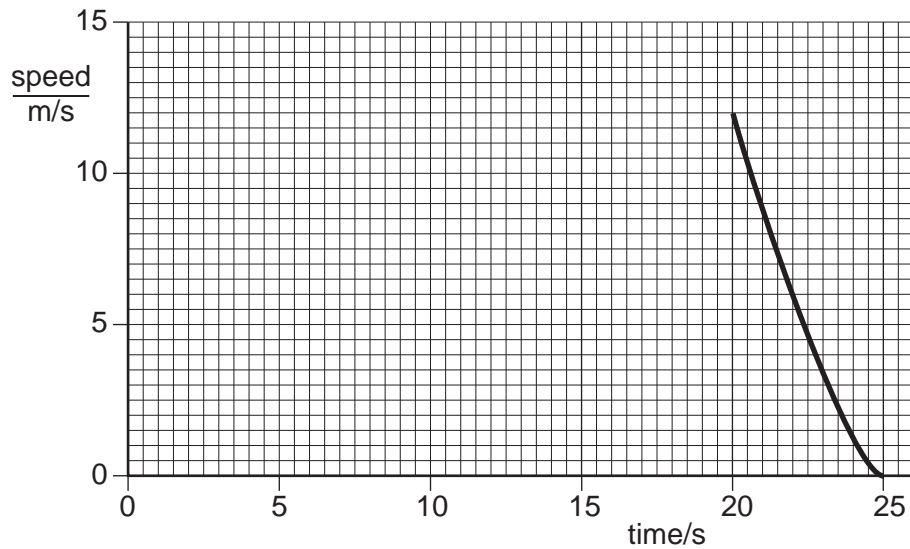

Fig. 1.1

- (a) On Fig. 1.1, complete the graph to show the first two parts of the journey. [3]
 (b) Calculate the acceleration of the bus 4.0 s after leaving the first bus stop.

acceleration = [2]

- (c) Use the graph to estimate the distance the bus travels between 20 s and 25 s.

estimated distance = [2]

- (d) On leaving the second bus stop, the uniform acceleration of the bus is 1.2 m/s^2 . The mass of the bus and passengers is 4000 kg.
 Calculate the accelerating force that acts on the bus.

force = [2]

- (e) The acceleration of the bus from the second bus stop is less than that from the first bus stop.
 Suggest two reasons for this.

1.

.....

2.

..... [2]

- 2 A student sets up the apparatus shown in Fig. 2.1 in order to find the resultant of the two tensions T_1 and T_2 acting at P. When the tensions T_1 , T_2 and T_3 are balanced, the angles between T_1 and the vertical and T_2 and the vertical are as marked on Fig. 2.1.

For
Examiner's
Use

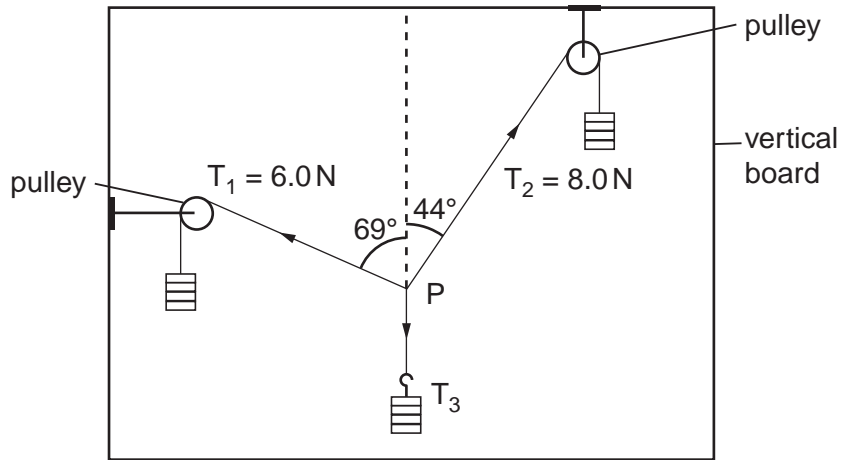

Fig. 2.1

In the space below, draw a scale diagram of the forces T_1 and T_2 . Use the diagram to find the resultant of the two forces.

State

(a) the scale used, scale =

(b) the value of the resultant, value =

(c) the direction of the resultant. direction =

[6]

3 An electric pump is used to raise water from a well, as shown in Fig. 3.1.

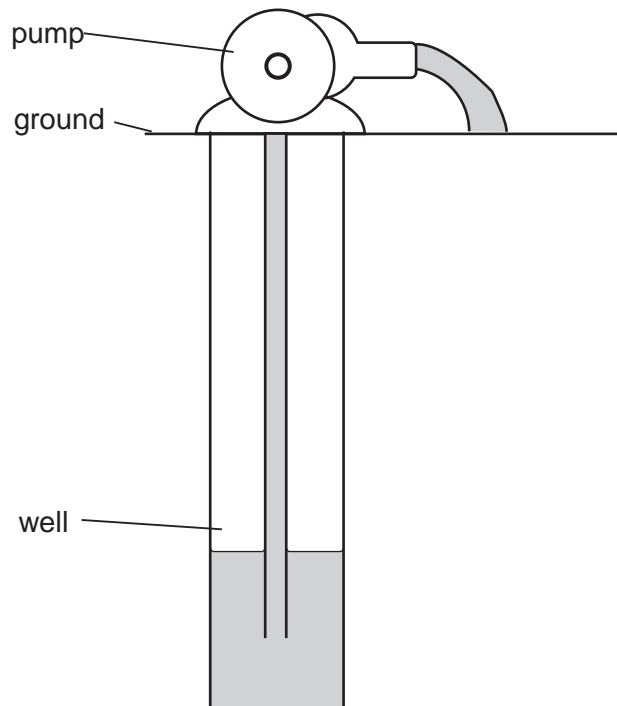

Fig. 3.1

(a) The pump does work in raising the water. State an equation that could be used to calculate the work done in raising the water.

.....[2]

(b) The water is raised through a vertical distance of 8.0m. The weight of water raised in 5.0s is 100N.

(i) Calculate the work done in raising the water in this time.

work done =[1]

(ii) Calculate the power the pump uses to raise the water.

power =[1]

(iii) The energy transferred by the pump to the water is greater than your answer to (i). Suggest what the additional energy is used for.

.....[1]

4 (a) State two differences between evaporation of water and boiling of water.

1.

2. [2]

(b) The specific latent heat of vaporisation of water is 2260 kJ/kg.
Explain why this energy is needed to boil water and why the temperature of the water does not change during the boiling.

.....

.....

.....

..... [3]

(c) A laboratory determination of the specific latent heat of vaporisation of water uses a 120 W heater to keep water boiling at its boiling point. Water is turned into steam at the rate of 0.050 g/s.
Calculate the value of the specific latent heat of vaporisation obtained from this experiment. Show your working.

specific latent heat of vaporisation = [3]

- 5 (a) Fig. 5.1 shows a tank used for evaporating salt solution to produce crystals.

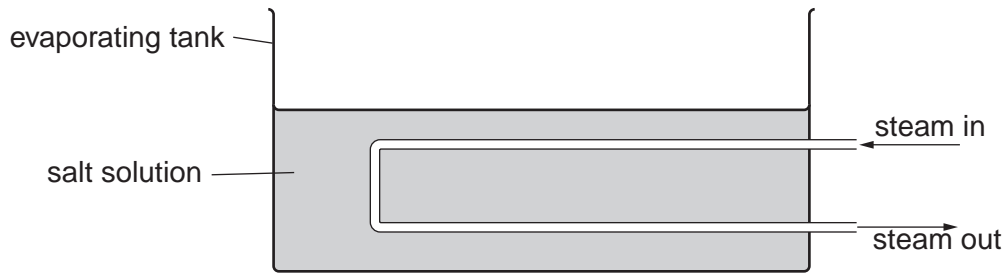

Fig. 5.1

Suggest two ways of increasing the rate of evaporation of the water from the solution. Changes may be made to the apparatus, but the rate of steam supply must stay constant. You may assume the temperature of the salt solution remains constant.

1.
.....
2.
.....[2]

- (b) A manufacturer of liquid-in-glass thermometers changes the design in order to meet new requirements.

Describe the changes that could be made to

- (i) give the thermometer a greater range,
.....[1]
- (ii) make the thermometer more sensitive.
.....[1]

- (c) A toilet flush is operated by the compression of air. The air inside the flush has a pressure of 1.0×10^5 Pa and a volume of 150cm^3 . When the flush is operated the volume is reduced to 50cm^3 . The temperature of the air remains constant during this process.
Calculate the new pressure of the air inside the flush.

pressure =[2]

- 6 Fig. 6.1 shows white light incident at P on a glass prism. Only the refracted red ray PQ is shown in the prism.

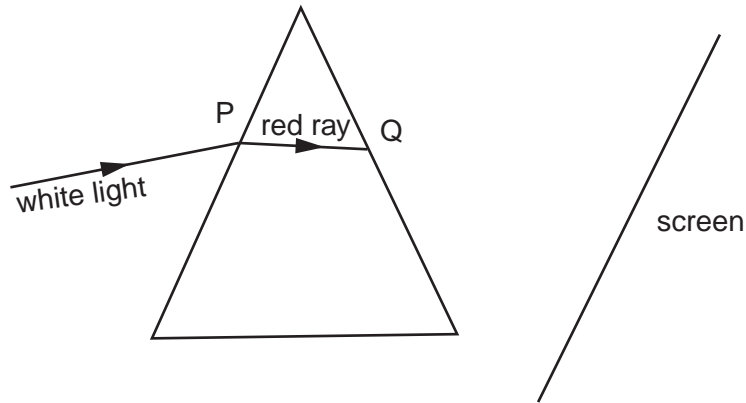

Fig. 6.1

- (a) On Fig. 6.1, draw rays to complete the path of the red ray and the whole path of the violet ray up to the point where they hit the screen. Label the violet ray. [3]
- (b) The angle of incidence of the white light is increased to 40° . The refractive index of the glass for the red light is 1.52.
Calculate the angle of refraction at P for the red light.

angle of refraction =[3]

- (c) State the approximate speed of

- (i) the white light incident at P, speed = [1]
- (ii) the red light after it leaves the prism at Q. speed = [1]

- 7 Fig. 7.1 shows how the air pressure at one instant varies with distance along the path of a continuous sound wave.

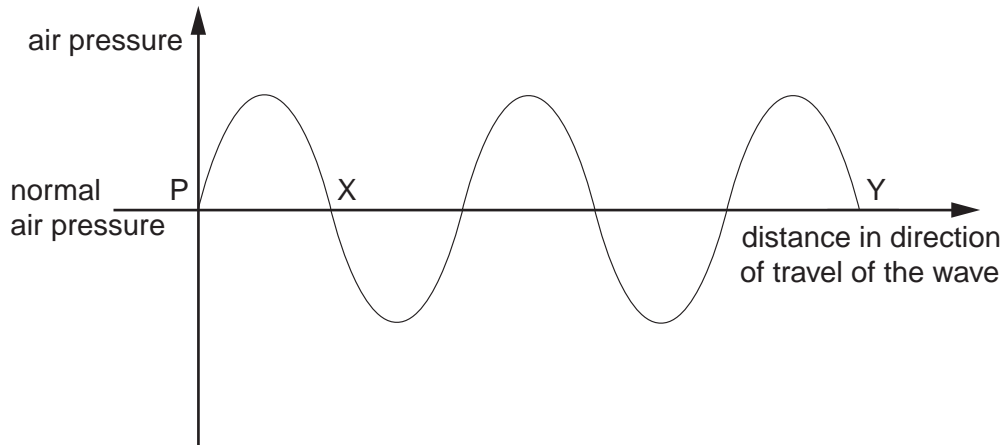

Fig. 7.1

- (a) What type of waves are sound waves?
.....[1]

- (b) On Fig. 7.1, mark on the axis PY
(i) one point C where there is a compression in the wave, [1]
(ii) one point R where there is a rarefaction in the wave. [1]

- (c) Describe the motion of a group of air particles situated on the path of the wave shown in Fig. 7.1.
.....
.....
.....[2]

- (d) The sound wave shown has speed of 340 m/s and a frequency of 200 Hz.
Calculate the distance represented by PX on Fig. 7.1.

distance =[2]

8 Fig. 8.1 shows an electrical circuit.

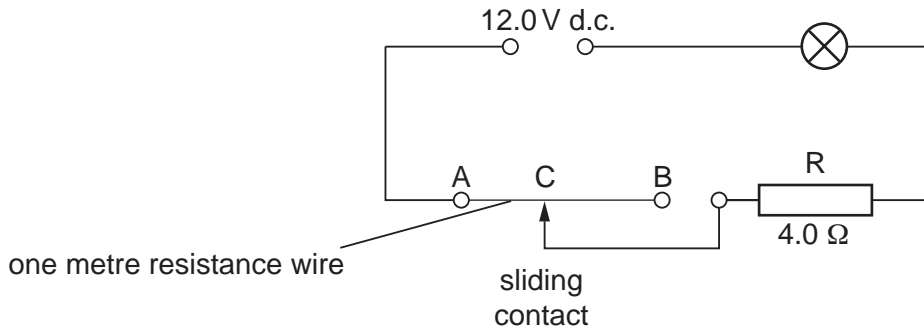

Fig. 8.1

The resistance of the lamp is $4.0\ \Omega$ when it is at its normal brightness.

- (a) The lamp is rated at 6.0V, 9.0W.
Calculate the current in the lamp when it is at its normal brightness.

current =[2]

- (b) The sliding contact C is moved to A. The lamp lights at its normal brightness.
Calculate

- (i) the total circuit resistance,

resistance =[1]

- (ii) the potential difference across the $4.0\ \Omega$ resistor R.

potential difference =[1]

- (c) The sliding contact C is moved from A to B.

- (i) Describe any change that occurs in the brightness of the lamp.

.....[1]

- (ii) Explain your answer to (i).

.....

.....[2]

- (d) The 1 m wire between A and B, as shown in Fig. 8.1, has a resistance of $2.0\ \Omega$.
Calculate the resistance between A and B when

- (i) the 1 m length is replaced by a 2 m length of the same wire,

resistance =[1]

- (ii) the 1 m length is replaced by a 1 m length of a wire of the same material but of only half the cross-sectional area.

resistance =[1]

9 A transformer is needed to step down a 240 V a.c. supply to a 12 V a.c. output.

(a) In the space below, draw a labelled diagram of a suitable transformer. [3]

(b) Explain

(i) why the transformer only works on a.c.,

.....
.....[1]

(ii) how the input voltage is changed to an output voltage.

.....
.....
.....[2]

(c) The output current is 1.5 A.

Calculate

(i) the power output,

power =[1]

(ii) the energy output in 30 s.

energy =[1]

- 10 (a) Fig. 10.1 shows a positively charged plastic rod, a metal plate resting on an insulator, and a lead connected to earth.

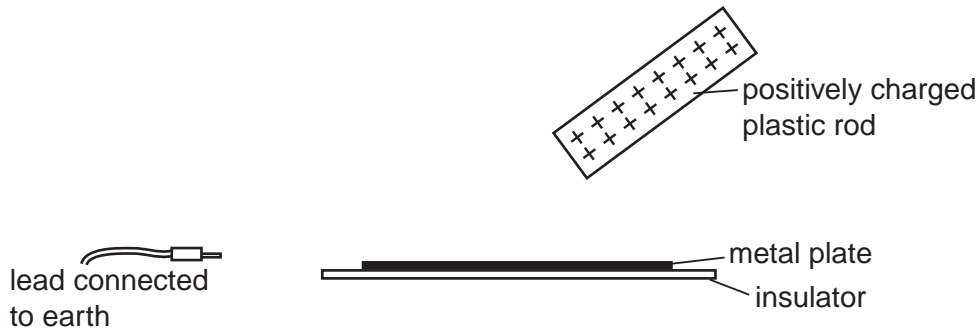

Fig. 10.1

Describe how the metal plate may be charged by induction.

.....

.....

.....[3]

- (b) An electrostatic generator sets up a current of 20 mA in a circuit.

Calculate

- (i) the charge flowing through the circuit in 15 s,

charge =

- (ii) the potential difference across a 10 kΩ resistor in the circuit.

potential difference =
[3]

- 11 Fig. 11.1 shows a beam of radiation that contains α -particles, β -particles and γ -rays. The beam enters a very strong magnetic field shown in symbol form by N and S poles.

For
Examiner's
Use

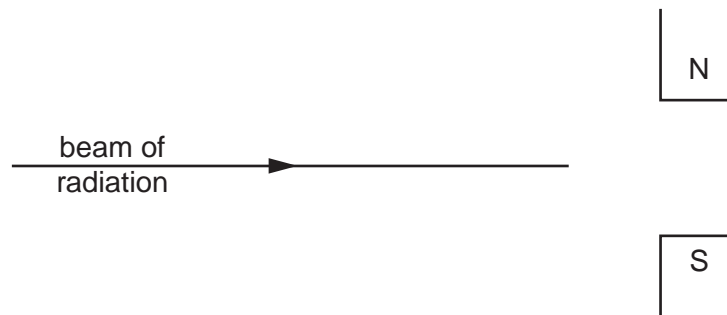

Fig. 11.1

Complete the table below.

radiation	direction of deflection, if any	charge carried by radiation, if any
α -particles		
β -particles		
γ -rays		

[6]

Permission to reproduce items where third-party owned material protected by copyright is included has been sought and cleared where possible. Every reasonable effort has been made by the publisher (UCLES) to trace copyright holders, but if any items requiring clearance have unwittingly been included, the publisher will be pleased to make amends at the earliest possible opportunity.

University of Cambridge International Examinations is part of the University of Cambridge Local Examinations Syndicate (UCLES), which is itself a department of the University of Cambridge.